

Insulation piercing connector SLIW57

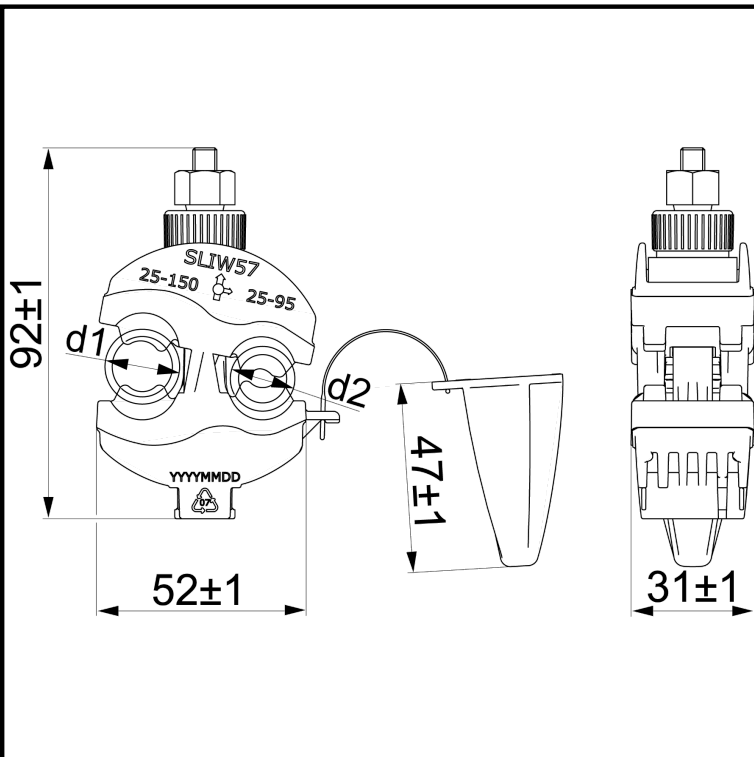

SLIW57 is for use with insulated aluminium or copper conductors. Fully insulated bolt provides safe live line working. Both main and branch conductor insulations are pierced by single bolt action. Test voltage 6 kV/50 Hz/1 min in water. Connector's design enables hot line installation without peeling insulation from conductor.

Code SLIW57
GTIN 6438100303686
Name Insulation piercing connector
 25-150 mm² / 25-95 mm², Waterproof



Dimensions

Weight	0.122 kg
Height	31 mm
Width	52 mm
Length	92 mm
Main conductor mm ²	25-150
Branch conductor mm ²	25-95
Conductor diameter mm	8.4-18.5 / 8.4-15.2

Environmental impact

GWP-fossil, A1-A3	0.91 kgCO ₂ e
GWP-fossil, A1-A3 /kg	7.49 kgCO ₂ e/kg
GWP reference standard	EN 15804+A2:2019
Environmental declaration type	EPD
Environmental declaration registration number	EPD HUB, HUB-0846
Environmental declaration expiry date	2028-11-16 12:00:00
EPD Hub link	https://manage.epdhub.com/declarations/any-other-construction-product/ensto-finland-ltd/1086/sliw-insulation-piercing-connector/ (EPD Hub-0846)

Certificates

Standards	ISO 14025, ISO 21930, EN 15804+A2, EN 50483-4:2009
-----------	--

Electrical values

Highest system voltage	1 kV
Test voltage in water	6 kV / 50 Hz / 1 min

Mechanical

Tightening torque Nm	15 Nm
----------------------	-------

ETIM

ETIM Class	EC001062
Nominal cross section main conductor, SM	25 ... 150 mm ²
Nominal cross section branch conductor, SE/RE	25 ... 95 mm ²
Nominal cross section branch conductor, SM/RM	25 ... 95 mm ²
Material main conductor	Aluminium/copper
Material branch conductor	Aluminium/copper
Terminal insulated	Yes
Clamping channel opening main conductor	Both sides open
Clamping channel opening branch conductor	Both sides open

Surface protection
Type of connection

Tinned
Insulation piercing connector IPC

ENSTO

Packaging

Plastic bag

Size	12 pcs
Depth	350 mm
Height	10 mm
Width	230 mm
Weight	1.473 kg
Volume	0.805 l

Carton

Size	60 pce
Depth	398 mm
Height	221 mm
Width	263 mm
Weight	7.639 kg
Volume	23.132954 l

Pallet package

Size	2160 pcs
Depth	1200 mm
Height	1140 mm
Width	800 mm
Weight	295.004 kg
Volume	1094.4 l

Downloads

[Installation instruction](#)

File type: PDF



[Dimensional drawing M1 \(new window\)](#)

File type: PDF



[Environmental product declaration EPD HUB-0846](#)

File type: PDF

