

**Data Sheet | Item Number: 2273-205**

PUSH WIRE® splicing connector; for solid conductors; max. 2.5 mm<sup>2</sup>; 5-conductor; transparent housing; yellow cover; Surrounding air temperature: max 60°C (T60); 2,50 mm<sup>2</sup>; transparent



<https://www.wago.com/2273-205>



Color:  transparent

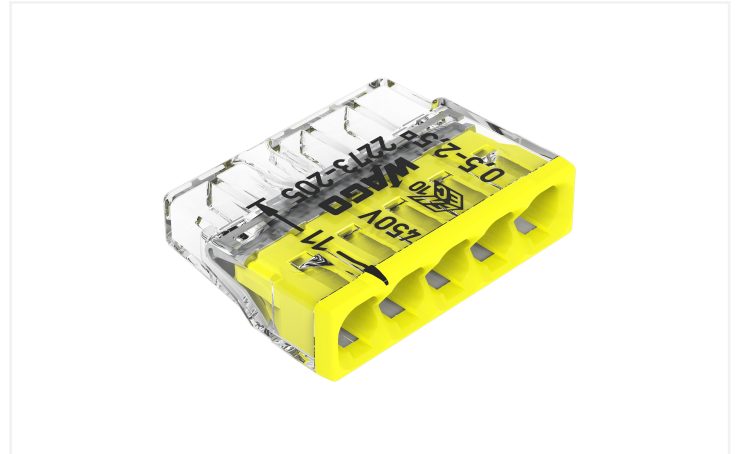

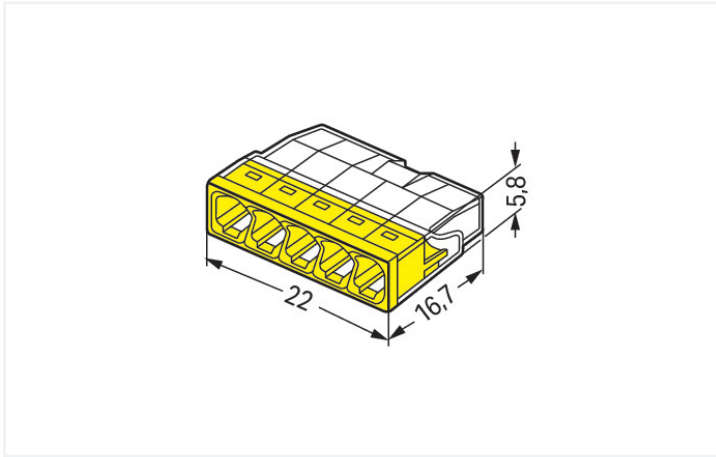

Dimensions in mm

Push wire® splicing connector, 2273 Series, PUSH WIRE®

Our push wire® splicing connector (item number 2273-205) ensures effortless electrical installations. The 2273 Series PUSH WIRE® connectors for junction boxes provide safe, quick, and easy installations in any building, no matter the position or location. Conductors can only be connected to push wire® splicing connector if their strip length is 11 mm. Our splicing connector is rated for 450 V and is designed for use with a rated current of up to 24 A. It is therefore suitable for high-load applications. Featuring conductor terminals along with PUSH WIRE®, this connector outperforms the competition. Our PUSH WIRE® connection is the simple and reliable method for connecting solid conductors. Dimensions: (22 x 5.8 x 16.7) mm (width x height x depth). Depending on the type of conductor, push wire® splicing connector is designed for conductor cross sections ranging from 0.5 mm<sup>2</sup> to 2.5 mm<sup>2</sup>.

Tin is used for coating the contact surfaces.

Notes	
General safety information	<p><b>NOTICE: Observe installation and safety instructions!</b></p> <ul style="list-style-type: none"> <li>▪ <b>Only to be used by electricians!</b></li> <li>▪ Do not work under voltage/load!</li> <li>▪ Use only for proper use!</li> <li>▪ Observe national regulations/standards/guidelines!</li> <li>▪ Observe technical specifications for the products!</li> <li>▪ Observe the number of permissible potentials!</li> <li>▪ Do not use damaged/dirty components!</li> <li>▪ Observe conductor types, cross-sections and strip lengths!</li> <li>▪ Insert conductor until it hits the product's backstop!</li> <li>▪ Use original accessories!</li> </ul> <p><b>To be sold only with installation instructions!</b></p>

Safety Information

in grounded power lines

Electrical data							
Ratings per	IEC/EN 60998			Approvals per	UL 486C		
	III	III	II		B	C	D
Overtoltage category	III	III	II	Use group	B	C	D
Pollution degree	3	2	2	Rated voltage	-	-	-
Nominal voltage	-	-	450 V	Rated current	-	-	-
Rated impulse withstand voltage	-	-	4 kV				
Rated current	-	-	24 A				

## General information

Wiring direction	Side-entry wiring
------------------	-------------------

## Connection Data

Clamping units	5
Total number of potentials	1

### Connection 1

Connection technology	PUSH WIRE®
Actuation type	Push-in
Connectable conductor materials	Copper Aluminum

Connectable conductor materials (note)

#### Terminating Aluminum Conductors

WAGO Spring-Clamp Terminal Blocks are suitable for solid aluminum conductors up to 4 mm<sup>2</sup>/12 AWG if WAGO "Alu-Plus" Contact Paste [249-130](#) is used for termination.

"Alu-Plus" Contact Paste Advantages:

- Automatically destroys the oxide film during clamping.
- Prevents fresh oxidation at the clamping point.
- Prevents electrolytic corrosion between aluminum and copper conductors (in the same terminal block).
- Provides long-term protection against corrosion.

For spring pressure connections with PUSH WIRE® connection technology, **WAGO recommends that the aluminum conductor first be cleaned** and then immediately inserted into the clamping unit filled with "Alu-Plus" contact paste.

It is also possible to apply WAGO "Alu-Plus" **additionally** on the whole surface of the aluminum conductor before termination.

Please note that the nominal currents must be adapted to the reduced conductivity of the aluminum conductors:

2.5 mm<sup>2</sup> = 16 A  
4 mm<sup>2</sup> = 22 A

Solid conductor	0.5 ... 2.5 mm <sup>2</sup> / 20 ... 16 AWG
Strip length	11 mm / 0.43 inches
Wiring direction	Side-entry wiring

## Physical data

Width	22 mm / 0.866 inches
Height	5.8 mm / 0.228 inches
Depth	16.7 mm / 0.657 inches

## Material data

Note (material data)	<a href="#">Information on material specifications can be found here</a>
Color	transparent
Cover color	yellow
Material group	IIIa
Insulation material (main housing)	Polycarbonate (PC)
Flammability class per UL94	V2
Clamping spring material	Chrome-nickel spring steel (CrNi)
Contact material	Electrolytic copper (E <sub>Cu</sub> )
Contact Plating	Tin
Fire load	0.03 MJ

### Material data

Weight	1.6 g
--------	-------

### Environmental requirements

Ambient temperature (operation)	+60 °C
Continuous operating temperature	105 °C
Temperature marking per EN 60998	T60

### Commercial data

Product Group	7 (Push Wire Conn.)
PU (SPU)	1000 (100) pcs
Packaging type	Box
Country of origin	DE
GTIN	4050821027874
Customs tariff number	85369010000

### Product Classification

UNSPSC	39121409
eCl@ss 10.0	27-14-11-04
eCl@ss 9.0	27-14-11-04
ETIM 9.0	EC000446
ETIM 10.0	EC000446
ECCN	NO US CLASSIFICATION

### Environmental Product Compliance

RoHS Compliance Status	Compliant, No Exemption
------------------------	-------------------------

### Approvals / Certificates

#### General approvals



Approval	Standard	Certificate Name
cULus_Listed_667F Underwriters Laboratories Inc.	UL 486C	E69654
VDE VDE Prüf- und Zerti- fizierungsinstitut	EN 60998	40029794

#### Declarations of conformity and manufacturer's declarations

Approval	Standard	Certificate Name
EU-Declaration of Conformity WAGO GmbH & Co. KG	-	-
UK-Declaration of Conformity WAGO GmbH & Co. KG	-	-

### Approvals for marine applications



Approval	Standard	Certificate Name
ABS American Bureau of Ship- ping	-	23-2417173-PDA
LR Lloyds Register	EN 60998	LR22207029TA
PRS Polski Rejestr Statków	EN 60998	TE/1093/880590/23

**Downloads**

**Environmental Product Compliance**

**Compliance Search**

Environmental Product Compliance 2273-205



**Documentation**

**Bid Text**

2273-205	19.02.2019	xml 3.17 KB	
2273-205	17.05.2017	doc 24.50 KB	
ausschreiben.de 2273-205			

**CAD/CAE-Data**

**CAD data**

2D/3D Models 2273-205



**CAE data**

EPLAN Data Portal  
2273-205



WSCAD Universe  
2273-205



ZUKEN Portal 2273-205



**1 Compatible Products**

**1.1 Optional Accessories**

**1.1.1 Mounting adapter**

**1.1.1.1 Mounting accessories**



**Item No.: 2273-500**

Mounting carrier; for single- and double-row con.; 2273 Series; for DIN-35 rail mounting/ screw mounting; orange

### 1.1.2 Tool

#### 1.1.2.1 "Alu-Plus" contact paste



Item No.: 249-130

Syringe; Contents: 20 ml Alu contact paste

### Installation Notes

#### Conductor termination



Strip solid conductor to 11 mm/0.43 inch (see marking).

The transparent housing shows if conductors are fully inserted; within the colored base, a clear port shows if the conductor's strip length is correct. Conductors are correctly stripped if the clear port shows no bare conductor on the unprinted connector side. Picture shows center conductor with exceeded strip length.

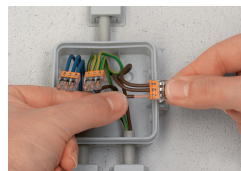

Termination: Insert the stripped solid conductor until it hits the backstop.



Removal: Hold conductor to be removed and twist alternately left and right while pulling the connector.

### Testing



Testing via test port opposite to conductor entry.