

Data Sheet | Item Number: 2273-202

PUSH WIRE® splicing connector; for solid conductors; max. 2.5 mm²; 2-conductor; transparent housing; white cover; Surrounding air temperature: max 60°C (T60); 2,50 mm²; transparent



<https://www.wago.com/2273-202>



Color: transparent



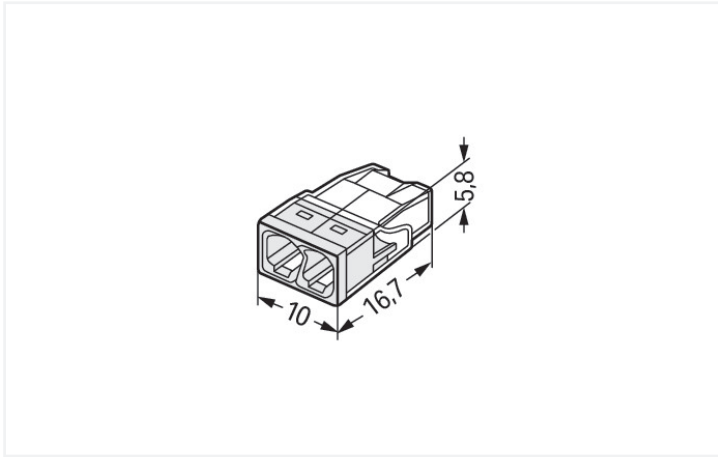

Dimensions in mm

Push wire® splicing connector, 2273 Series, Push-in

Error-free electrical installations are guaranteed with push wire® splicing connector (item number 2273-202). Quickly and securely connect conductors in any building installation with WAGO's 2273 Series PUSH WIRE® connectors, designed for both surface and flush-mounted junction boxes. Whether you intend to use them in private or commercial applications, this series of PUSH WIRE® connectors for junction boxes ensures simple and time-saving installations. Strip lengths must be 11 mm when connecting conductors to push wire® splicing connector. This splicing connector has a rated voltage of 450 V and can handle currents up to 24 A, making it ideal for high-load applications. This product features conductor terminals and utilizes PUSH WIRE®. Our PUSH WIRE® connection offers a quick and simple method for connecting solid conductors. The dimensions are (10 x 5.8 x 16.7) mm (width x height x depth). Push wire® splicing connector is suitable for conductor cross sections ranging from 0.5 mm² to 2.5 mm².

Tin is used for coating the contact surfaces.

Notes	
General safety information	<p>NOTICE: Observe installation and safety instructions!</p> <ul style="list-style-type: none"> • Only to be used by electricians! • Do not work under voltage/load! • Use only for proper use! • Observe national regulations/standards/guidelines! • Observe technical specifications for the products! • Observe the number of permissible potentials! • Do not use damaged/dirty components! • Observe conductor types, cross-sections and strip lengths! • Insert conductor until it hits the product's backstop! • Use original accessories! <p>To be sold only with installation instructions!</p>

Safety Information in grounded power lines

Electrical data

Ratings per	IEC/EN 60998		
Overvoltage category	III	III	II
Pollution degree	3	2	2
Nominal voltage	-	-	450 V
Rated impulse withstand voltage	-	-	4 kV
Rated current	-	-	24 A

Approvals per	UL 486C		
Use group	B	C	D
Rated voltage	-	-	-
Rated current	-	-	-

General information

Wiring direction	Side-entry wiring
------------------	-------------------

Connection Data

Clamping units	2
Total number of potentials	1

Connection 1

Connection technology	PUSH WIRE®
Actuation type	Push-in
Connectable conductor materials	Copper Aluminum

Connectable conductor materials (note)

Terminating Aluminum Conductors

WAGO Spring-Clamp Terminal Blocks are suitable for solid aluminum conductors up to 4 mm²/12 AWG if WAGO "Alu-Plus" Contact Paste [249-130](#) is used for termination.

"Alu-Plus" Contact Paste Advantages:

- Automatically destroys the oxide film during clamping.
- Prevents fresh oxidation at the clamping point.
- Prevents electrolytic corrosion between aluminum and copper conductors (in the same terminal block).
- Provides long-term protection against corrosion.

For spring pressure connections with PUSH WIRE® connection technology, **WAGO recommends that the aluminum conductor first be cleaned** and then immediately inserted into the clamping unit filled with "Alu-Plus" contact paste.

It is also possible to apply WAGO "Alu-Plus" **additionally** on the whole surface of the aluminum conductor before termination.

Please note that the nominal currents must be adapted to the reduced conductivity of the aluminum conductors:

2.5 mm² = 16 A
4 mm² = 22 A

Solid conductor	0.5 ... 2.5 mm ² / 20 ... 16 AWG
Strip length	11 mm / 0.43 inches
Wiring direction	Side-entry wiring

Physical data

Width	10 mm / 0.394 inches
Height	5.8 mm / 0.228 inches
Depth	16.7 mm / 0.657 inches

Material data

Note (material data)	Information on material specifications can be found here
Color	transparent
Cover color	white
Material group	IIIa
Insulation material (main housing)	Polycarbonate (PC)
Flammability class per UL94	V2
Clamping spring material	Chrome-nickel spring steel (CrNi)
Contact material	Electrolytic copper (E _{Cu})
Contact Plating	Tin
Fire load	0.022 MJ

Material data

Weight	0.7 g
--------	-------

Environmental requirements

Ambient temperature (operation)	+60 °C
Continuous operating temperature	105 °C
Temperature marking per EN 60998	T60

Commercial data

Product Group	7 (Push Wire Conn.)
PU (SPU)	1000 (100) pcs
Packaging type	Box
Country of origin	DE
GTIN	4050821027843
Customs tariff number	85369010000

Product Classification

UNSPSC	39121409
eCl@ss 10.0	27-14-11-04
eCl@ss 9.0	27-14-11-04
ETIM 9.0	EC000446
ETIM 10.0	EC000446
ECCN	NO US CLASSIFICATION

Environmental Product Compliance

RoHS Compliance Status	Compliant, No Exemption
------------------------	-------------------------

Approvals / Certificates

General approvals



Approval	Standard	Certificate Name
cULus_Listed_667F Underwriters Laboratories Inc.	UL 486C	E69654
VDE VDE Prüf- und Zerti- fizierungsinstitut	EN 60998	40029794

Declarations of conformity and manufacturer's declarations

Approval	Standard	Certificate Name
EU-Declaration of Conformity WAGO GmbH & Co. KG	-	-
UK-Declaration of Conformity WAGO GmbH & Co. KG	-	-

Approvals for marine applications



Approval	Standard	Certificate Name
ABS American Bureau of Ship- ping	-	23-2417173-PDA
LR Lloyds Register	EN 60998	LR22207029TA
PRS Polski Rejestr Statków	EN 60998	TE/1093/880590/23

Downloads

Environmental Product Compliance

Compliance Search	
Environmental Product Compliance 2273-202	↓

Documentation

Bid Text			
2273-202	19.02.2019	xml 3.17 KB	↓
2273-202	17.05.2017	doc 24.50 KB	↓
ausschreiben.de 2273-202			↓

CAD/CAE-Data

CAD data
2D/3D Models 2273-202

CAE data
EPLAN Data Portal 2273-202
WSCAD Universe 2273-202
ZUKEN Portal 2273-202

1 Compatible Products

1.1 Optional Accessories

1.1.1 General accessories

1.1.1.1 Moisture protection



Item No.: 207-1331
Gelbox; Branch; for cables; with gel; 221, 2x73 Series; max. 4 mm² connectors; without splicing connectors; Size 1; gray

Item No.: 207-1332
Gelbox; Branch; for cables; with gel; 221, 2x73 Series; max. 4 mm² connectors; without splicing connectors; Size 2; gray

Item No.: 207-1333
Gelbox; Branch; for cables; with gel; 221, 2x73 Series; max. 4 mm² connectors; without splicing connectors; Size 3; gray

1.1.2 Mounting adapter

1.1.2.1 Mounting accessories



Item No.: 2273-500

Mounting carrier; for single- and double-row con.; 2273 Series; for DIN-35 rail mounting/ screw mounting; orange

1.1.3 Tool

1.1.3.1 "Alu-Plus" contact paste



Item No.: 249-130

Syringe; Contents: 20 ml Alu contact paste

Installation Notes

Conductor termination

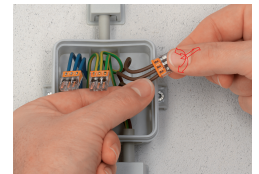
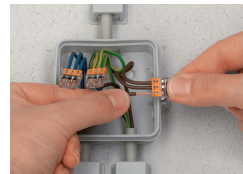

Strip solid conductor to 11 mm/0.43 inch (see marking).

The transparent housing shows if conductors are fully inserted; within the colored base, a clear port shows if the conductor's strip length is correct. Conductors are correctly stripped if the clear port shows no bare conductor on the unprinted connector side. Picture shows center conductor with exceeded strip length.

Termination: Insert the stripped solid conductor until it hits the backstop.

Removal: Hold conductor to be removed and twist alternately left and right while pulling the connector.

Testing



Testing via test port opposite to conductor entry.