

Data Sheet | Item Number: 221-415

Splicing connector with levers; for all conductor types; max. 4 mm²; 5-conductor; transparent housing; Surrounding air temperature: max 85°C (T85); 4,00 mm²; transparent

<https://www.wago.com/221-415>



Color: transparent



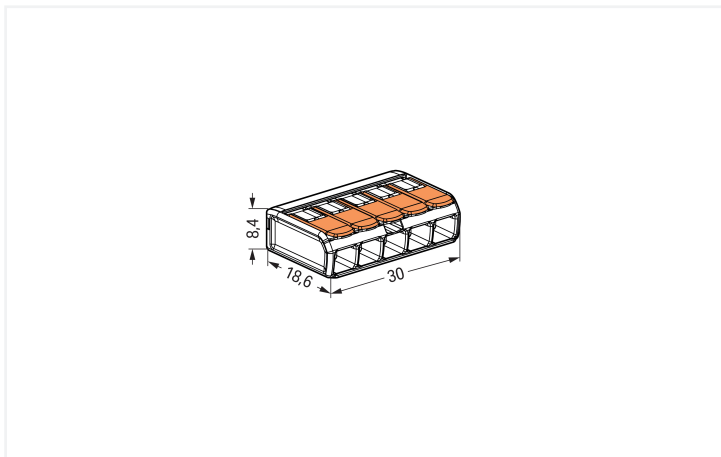

Dimensions in mm

Splicing connector with levers, 221 Series, transparent

Splicing connector with levers (item number 221-415) simplifies electrical installations. From wiring intercom systems to installing electrical ovens, connecting different conductor types is quick and simple with WAGO's compact 221 Series splicing connector, which allows you to quickly and safely connect different types of conductors. Ensure that the strip lengths are 11 mm when connecting conductors to splicing connector with levers. This splicing connector has a rated voltage of 450 V and can handle currents up to 32 A, making it ideal for high-load applications. This product incorporates conductor terminals and utilizes CAGE CLAMP®. Our proven universal connection known as CAGE CLAMP® is the industry standard when it comes to connection technology and electrical interconnections. The dimensions are (30 x 8.4 x 18.6) mm (width x height x depth). Depending on the conductor type, splicing connector with levers is ideal for conductor cross sections ranging from 0.2 mm² to 4 mm².

WAGO's 221 Series Splicing Connector with levers impresses with its innovative design for different conductor cross-sections. That's why WAGO's lever-equipped splicing connector holds a unique trademark within electrical interconnection technology. The flat levers, which fit seamlessly into the 221's base, act like a cast when closed and can be positioned neatly in any housing without disturbing edges. Due to the wide design of each lever, they can all be operated perfectly without tools for convenient conductor terminations. The transparent housing displays robust technology and enables immediate visual inspection for the correct contact of solid, stranded and fine-stranded conductors. Resembling piano keys, the levers' design perfectly combines the functional and aesthetic connection technology "Made by WAGO." This product is designed for specific Ex applications (please refer to the product datasheet).

Notes

General safety information

NOTICE: Observe installation and safety instructions!

- **Only to be used by electricians!**
- Do not work under voltage/load!
- Use only for proper use!
- Observe national regulations/standards/guidelines!
- Observe technical specifications for the products!
- Observe the number of permissible potentials!
- Do not use damaged/dirty components!
- Observe conductor types, cross-sections and strip lengths!
- Insert conductor until it hits the product's backstop!
- Use original accessories!

To be sold only with installation instructions!

Safety Information

in grounded power lines

Electrical data

Ratings per	EN 60664		
Overvoltage category	III	III	II
Pollution degree	3	2	2
Nominal voltage	-	-	450 V
Rated impulse withstand voltage	-	-	4 kV
Rated current	-	-	32 A

Approvals per	UL 486C		
Use group	B	C	D
Rated voltage	-	600 V	-
Rated current	-	20 A	-

General information

Wiring direction	Side-entry wiring
------------------	-------------------

Connection Data

Clamping units	5	Connection 1	
Total number of potentials	1	Connection technology	CAGE CLAMP®
		Actuation type	Lever
		Connectable conductor materials	Copper
		Nominal cross-section	4 mm ² / 12 AWG
		Solid conductor	0.2 ... 4 mm ² / 24 ... 12 AWG
		Stranded conductor	0.2 ... 4 mm ² / 24 ... 12 AWG
		Fine-stranded conductor	0.14 ... 4 mm ² / 24 ... 12 AWG
		Strip length	11 mm / 0.43 inches
		Wiring direction	Side-entry wiring

Physical data

Width	30 mm / 1.181 inches
Height	8.4 mm / 0.331 inches
Depth	18.6 mm / 0.732 inches

Material data

Note (material data)	Information on material specifications can be found here
Color	transparent
Material group	IIIa
Insulation material (main housing)	Polycarbonate (PC)
Flammability class per UL94	V2
Fire load	0.074 MJ
Actuator color	orange
Weight	4 g

Environmental requirements

Ambient temperature (operation)	+85 °C
Continuous operating temperature	105 °C
Temperature marking per EN 60998	T85

Commercial data

Product Group	7 (Push Wire Conn.)
PU (SPU)	250 (25) pcs
Packaging type	Box
Country of origin	DE
GTIN	4055143234658
Customs tariff number	85369010000

Product Classification

UNSPSC	39121409
eCl@ss 10.0	27-14-11-04
eCl@ss 9.0	27-14-11-04
ETIM 9.0	EC000446
ETIM 10.0	EC000446
ECCN	NO US CLASSIFICATION

Environmental Product Compliance

RoHS Compliance Status	Compliant, No Exemption
------------------------	-------------------------

Approvals / Certificates

General approvals



Approval	Standard	Certificate Name
CCA DEKRA Certification B.V.	EN 60998	NTR NL-7990
cULus_Listed_667F Underwriters Laboratories Inc.	UL 486C	E69654
ENEC 05 DEKRA Certification B.V.	EN 60998	71-152284
UL Underwriters Laboratories Inc.	UL 467	E201573

Declarations of conformity and manufacturer's declarations

Approval	Standard	Certificate Name
EU-Declaration of Conformity WAGO GmbH & Co. KG	-	-
UK-Declaration of Conformity WAGO GmbH & Co. KG	-	-

Approvals for marine applications



Approval	Standard	Certificate Name
ABS American Bureau of Shipping	EN 60998	23-2417173-PDA
LR Lloyds Register	EN 60998	LR2446364TA
PRS Polski Rejestr Statków	EN 60998	TE/1093/880590/23

Downloads

Environmental Product Compliance

Compliance Search

Environmental Product Compliance 221-415



Documentation

Bid Text

221-415	19.02.2019	xml 3.43 KB	
221-415	23.01.2019	docx 15.31 KB	
ausschreiben.de 221-415			

CAD/CAE-Data

CAD data

2D/3D Models 221-415



CAE data

EPLAN Data Portal
221-415



ZUKEN Portal 221-415



1 Compatible Products

1.1 Optional Accessories

1.1.1 General accessories

1.1.1.1 Empty housings



Item No.: 207-4301

Junction box; Branch; for multicore cables; 221 Series; max. 4 mm² connectors; without splicing connectors; white

1.1.1.2 Moisture protection



Item No.: 207-1332

Gelbox; Branch; for cables; with gel; 221, 2x73 Series; max. 4 mm² connectors; without splicing connectors; Size 2; gray

1.1.2 Jumper

1.1.2.1 Jumper



Item No.: 221-941/000-006
Jumper; for conductor entry; 2-way; insulated; blue



Item No.: 221-942/000-006
Jumper; for conductor entry; 2-way; insulated; blue



Item No.: 221-941
Jumper; for conductor entry; 2-way; insulated; dark gray



Item No.: 221-942
Jumper; for conductor entry; 2-way; insulated; dark gray

1.1.3 Mounting adapter

1.1.3.1 Mounting accessories



Item No.: 221-500/000-006
Mounting carrier; 221 Series - 4 mm²; for DIN-35 rail mounting/screw mounting; blue



Item No.: 221-500/000-053
Mounting carrier; 221 Series - 4 mm²; for DIN-35 rail mounting/screw mounting; dark gray-yellow



Item No.: 221-500
Mounting carrier; 221 Series - 4 mm²; for DIN-35 rail mounting/screw mounting; orange



Item No.: 221-505/000-004
Mounting carrier; for 5-conductor terminal blocks; 221 Series - 4 mm²; for screw mounting; black



Item No.: 221-505
Mounting carrier; for 5-conductor terminal blocks; 221 Series - 4 mm²; for screw mounting; white



Item No.: 221-515/000-004
Mounting carrier; for 5-conductor terminal blocks; 221 Series - 4 mm²; with snap-in mounting foot for horizontal mounting; black



Item No.: 221-515
Mounting carrier; for 5-conductor terminal blocks; 221 Series - 4 mm²; with snap-in mounting foot for horizontal mounting; white



Item No.: 221-525/000-004
Mounting carrier; for 5-conductor terminal blocks; 221 Series - 4 mm²; with snap-in mounting foot for vertical mounting; black



Item No.: 221-525
Mounting carrier; for 5-conductor terminal blocks; 221 Series - 4 mm²; with snap-in mounting foot for vertical mounting; white

Installation Notes

Conductor termination

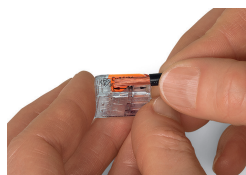

Strip conductor to 11 mm (0.43 inch).

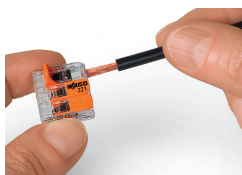

Pull up an orange lever to open the clamping unit.

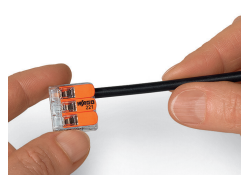

Then insert the conductor and push the lever back down, flush with the connector housing.

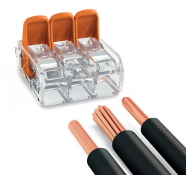

Compact, lever-operated splicing connectors:

Tool-free connection of fine-stranded conductors from 0.14 ... 4 mm², as well as solid or stranded conductors from 0.2 ... 4 mm² (24 ... 12 AWG).

Safety:

The lever's specially designed rest position reliably prevents accidental unclamping of a connected conductor.

Application safety, for any type of conductor (solid, stranded, fine-stranded), is confirmed by approvals like ENEC or UL.

Application

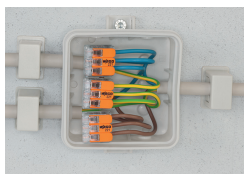

Wiring fine-stranded conductors in junction boxes.



Custom low-voltage lighting system



Lighting distribution in a ceiling canopy



Pendant light connection in a suspended ceiling