



Switchgear

Product catalogue 2025

CONTENTS

04	Vertical fuse switch disconnectors ARS evo, smartARS pro	04
	ARS 00 evo	08
	ARS 2 evo	11
	ARS 3 evo	11
	smartARS-X pro	16
	smartARS-XT pro	19
	smartARS P pro	21
	smartARS pro-PV	24
	smartARS IP20	27
31	Vertical fuse switch disconnectors ARS pro	31
	ARS 00/60 mm pro	34
	ARS 00/100 mm pro	35
	ARS 630 kVA pro	37
	ARS 1250 pro	38
	ARS pro with lateral busbar terminals	39
40	Vertical switch disconnectors RWS pro	40
	RWS 600 pro	40
	RWS 750 pro	41
	RWS 1250 pro	42
	ARS evo, smartARS pro, ARS pro, RWS pro – dimensions	43
	ARS evo, smartARS pro, ARS pro, RWS pro – accessories	55
61	Vertical fuse rails PBS	61
	PBS 00/100 mm	64
	PBS 00	68
	PBS 1, 2, 3	67
	PBS with lateral busbar terminals	68
	PBS – dimensions	69
	PBS – accessories	73
75	Fuse switch disconnectors RBK pro	75
	RBK 000 pro	79
	RBK 000 pro	81
	RBK 00 pro	83
	RBK 1 pro	84
	RBK 2 pro	96
	RBK 3 pro	98
	Electronic fuse monitoring module	99
100	Fuse switch disconnectors RBK	100
	RBK 00	103
	RBK 1	104
	RBK pro, RBK – dimensions	106
	RBK pro, RBK – accessories	117
125	Fuse bases PBD	125
	PBD – dimensions	128
	PBD – accessories	130
134	APASYS 60 - 60 mm busbar system	134
150	Switch disconnectors COMPASS	150
	mSDF 80	151
156	Cam switches 4G	156
	Standard connection diagrams	163
	Overall dimensions	190
199	Switch disconnectors RA, switch disconnectors fuses RAB	199
	RA 100, 160, 250, 400, 630, 1250	200
	RA – dimensions	204
	RAB 000, 00, 1, 2, 3	208
	RAB – dimensions	211
	RA, RAB – accessories	213
216	Modular equipment - mounted on DIN 35 mm rail	216



ARS evo, smartARS pro

vertical fuse switch disconnectors

- thermoplastics of V0 flammability class
- arc chambers with deionization plates over every contact
- fast installation
- adapted to existing assembly systems
- reversibility - top/bottom cable terminal connection
- wide range of accessories

GENERAL INFORMATION

ARS evo, smartARS pro vertical fuse switch disconnectors are designed for distribution of electricity and protection against short circuits and overloads in three phase alternative current circuits. They are intended for direct installation on horizontal or vertical busbar systems.

ARS evo, smartARS pro fuse switch disconnectors meet technical requirements of polish and european electricity boards and are conformed with EN 60947-1, EN 60947-3, IEC 60947-1, IEC 60947-3 standards.

ARS evo, smartARS pro fuse switch disconnectors are dedicated for applications which require reliability and safety like low voltage distribution boards installed in transformer substations, industrial low voltage switchgear assemblies and cable cabinets. Design of **ARS evo, smartARS pro** fuse switch disconnectors provides clearly visible, safe gap in the current circuit after the fuse link removal.

ARS evo, smartARS pro fuse switch disconnectors are designed to perform the following functions:

- protection,
- energy distribution,
- earthing,
- switching,
- touch protection.

OPERATING CONDITIONS

- to be installed in the room free of any dust, aggressive or explosive gases,
- altitude up to 2000 meters above sea level,
- ambient temperature from -25°C to +55°C,

CONSTRUCTION

ARS evo, smartARS pro fuse switch disconnectors are manufactured in two versions:

- one pole switching (separately each pole),
- three pole switching (three poles at the same time).

They have manually operated handle therefore making and breaking operations should be done with determined movement.

ARS evo, smartARS pro fuse switch disconnectors are available in following sizes (according to rated current): 00 (160 A); 2 (400 A); 3(630 A).

ARS evo, smartARS pro fuse switch disconnectors are designed for installation on to 185 mm busbar system.

All plastic parts of fuse switch disconnector **ARS evo, smartARS pro** are made of halogen free, fibre glass strengthened, self extinguishing materials. Thanks to the application of flame retardants the highest flammability class – V0 was achieved. Fuse switch disconnectors made from such termoplastics self-extinguish in specified time after ignition source is removed. Also dripping of flaming parts of plastic does not occur.

Silver plated contacts provide low power loss. Depending on clamp type, **ARS evo, smartARS pro** fuse switch disconnectors enable user to connect circular or sector-shaped conductors with bare ends or conductors with lug terminals. Arc chambers equipped with steel deionization plates are installed over each contact. Protection degree of IP30 from the front is provided. In opened position **ARS evo, smartARS pro** provide protection degree IP20. Additionally offered accesories enable to install **ARS evo, smartARS pro** fuse switch disconnectors of different sizes on common busbar systems and facilitate operation. All sizes of **ARS evo, smartARS pro** fuse switch disconnectors are provided complete with clamps (i. e. screws, V-terminals, 2V-terminals) and shrouds for cable terminals.



ARS evo

vertical fuse switch disconnectors

- stable and safe power distribution network
- parking position
- the fuse link can be released without touching it
- special construction allows better heat dissipation
- easy to install
- non-parallel disconnector
- 2 versions of switching: single-pole and three-pole
- retractable handle
- reversibility – top/bottom cable terminal connection
- padlock can be installed in open/closed position

Based on our long experience in the field of switchgear, we have developed a structurally wellthought-out solution in the form of a fuse switch disconnecter, the **ARS evo**. It is an outstanding product with features such as safety, functionality and flexibility.



Safety

- stable and safe power distribution network
- parking position
- the fuse link can be released without touching it
- special construction allows better heat dissipation



Functionality

- easy to install
- non-parallel disconnecter
- 2 versions of switching: single-pole and three-pole



Flexibility

- retractable handle
- reversibility – top/bottom cable terminal connection
- padlock can be installed in open/closed position

Versions of ARS evo



ARS 00-1 evo



ARS 00-3 evo



ARS 2-1 evo



ARS 2-6 evo



ARS 3-1 evo



ARS 3-6 evo

ARS 00 evo

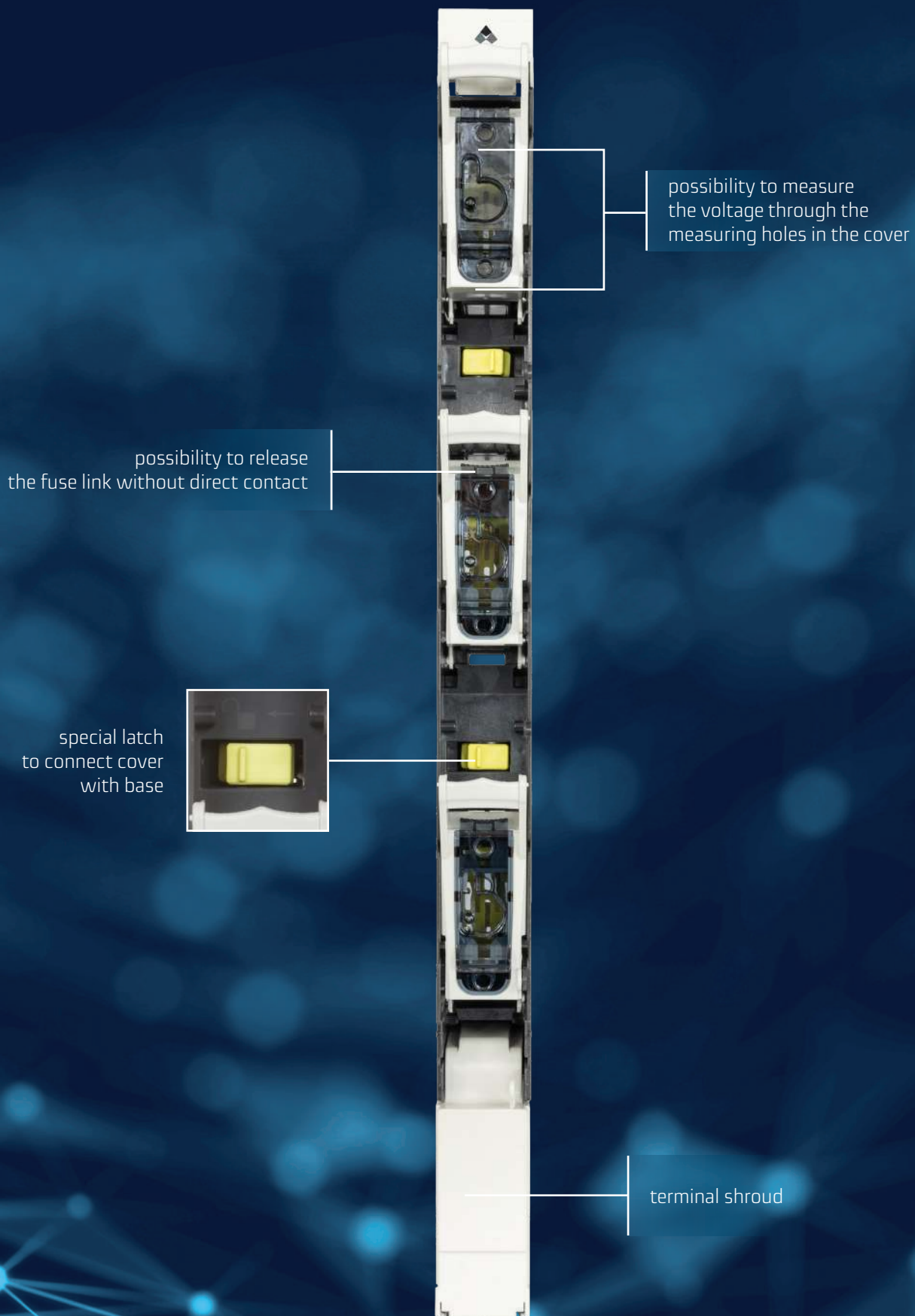



ARS 00-1-M evo
single-pole switching

open position



ARS 00-3-M evo
three-pole switching

open position



ARS 00-3-M evo
three-pole switching

parking position





Table 1. Technical data of ARS 00 evo

Parameter	ARS 00 evo	
Rated thermal current $I_{th}=I_n$	A	160
Rated voltage U_n	V	690
Utilization category	-	AC-23B AC-22B
Rated operational voltage U_e	V	400 690
Rated operational current I_e	A	160
Rated short circuit making current	690 V	80
	500 V	100
Rated short circuit withstand current	690 V	80
	500 V	100
Rated insulation voltage U_i	V	1000
Rated impulse withstand voltage $U_{imp.}$	kV	8
Rated frequency	Hz	50-60
Mechanical durability	Number	1600
Electrical durability	of cycles	200
IP degree of protection	-	30
Fuse links size	-	00
Max. permis. power loss per fuse-link NH 00	W	12

Table 2. Versions of ARS 00 evo

Fuse switch disconnecter ARS 00 evo – 160 A		Article No.
For installation on 185 mm busbar system; SINGLE-POLE SWITCHING – each phase independently		
ARS 00-1 evo	cable terminals: bridge terminals (S) 4-70 mm ²	63-500750-601
ARS 00-1-V evo	cable terminals: V-terminals: V-clamps 25-150 SW B	63-500750-602
ARS 00-1-M evo	cable terminals: M8 screw terminals	63-500750-603
ARS 00-1-2T evo	cable terminals: double frame clamp	63-500750-607
Higher version; SINGLE-POLE SWITCHING – each phase independently		
ARS 00-1-W evo	cable terminals: bridge terminals (S) 4-70 mm ²	63-500750-611
ARS 00-1-V-W evo	cable terminals: V-terminals: V-clamps 25-150 SW B	63-500750-612
ARS 00-1-M-W evo	cable terminals: M8 screw terminals	63-500750-613
ARS 00-1-2T-W evo	cable terminals: double frame clamp	63-500750-617
For installation on 185 mm busbar system; THREE-POLE SWITCHING – all phases simultaneously		
ARS 00-3 evo	cable terminals: bridge terminals (S) 4-70 mm ²	63-500750-701
ARS 00-3-V evo	cable terminals: V-terminals: V-clamps 25-150 SW B	63-500750-702
ARS 00-3-M evo	cable terminals: M8 screw terminals	63-500750-703
ARS 00-3-2T evo	cable terminals: double frame clamp	63-500750-707
Higher version; THREE-POLE SWITCHING – all phases simultaneously		
ARS 00-3-W evo	cable terminals: bridge terminals (S) 4-70 mm ²	63-500750-711
ARS 00-3-V-W evo	cable terminals: V-terminals: V-clamps 25-150 SW B	63-500750-712
ARS 00-3-M-W evo	cable terminals: M8 screw terminals	63-500750-713
ARS 00-3-2T-W evo	cable terminals: double frame clamp	63-500750-717

Table 3. ARS 00 evo terminal clamps

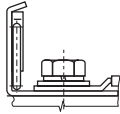
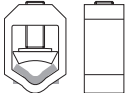
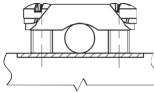
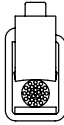
Description	ARS 00-M evo	ARS 00-V evo	ARS 00 evo	ARS 00 2T evo
Clamp	M8 screw*	V-clamp 25-150 SW B	S-bridge clamp 2 x M5 x 20	double frame clamp
Picture of clamp				
Drawing of clamp				
Cross-section of conductors	Conductor with lug terminal max. 185 mm ²	re ● 16 mm ² -95 mm ² se ◆ 25 mm ² -150 mm ² rm ⊞ 16 mm ² -95 mm ² sm ⊞ 25 mm ² -120 mm ²	4-70 mm ²	4 ÷ 95 mm ²
Tightening torque	12 Nm**	20 Nm**	3 Nm**	5 Nm**

For stranded conductors using cable ferrules is recommended

*) bars of maximum width of 20 mm and maximum thickness of 5 mm can be fixed to M type screw terminals

***) using tension wrench is recommended

Apator takes responsibility for technical quality of V-terminals manufactured only by the company. Minimum tightening torque (M8 screw) for screws fixing fuse switch disconnecter to busbar system – 12 Nm, recommended tightening torque for screws and nuts with property class 8.8 – 21 Nm.

Table 4. Accessories

Description	Article No.	Picture
Extended terminal shroud	51-823245-001	

ARS evo

retractable handle
in the single-pole switching version



arc chamber
with deionization
plates over upper
contacts

possibility to measure
the voltage through the
measuring holes in the cover

possibility to release
the fuse link without direct contact

special screw
to connect cover
with base



possibility
to install a
microswitch



terminal shroud
integrated with cover





ARS 2-1-V evo
single-pole switching

**closed position
parking position
open position**



ARS 3-1-M evo
single-pole switching

**in the closed position
there is possibility
to retract the handle**



ARS 2-6-2V evo
three-pole switching

open position



ARS 3-6-M evo
three-pole switching

parking position

Table 5. Technical data of ARS 2, 3 evo

Parameter		ARS 2 evo	ARS 3 evo
Rated thermal current $I_{th}=I_n$	A	400	630
Rated voltage U_n	V	690	690
Utilization category			single-pole switching
			three-pole switching
		AC 22B/690 V/400 A	AC 21B/690 V/630 A
		AC 23B/400 V/400 A	AC 22B/500 V/630 A
Rated operational voltage U_e	V	690	690
Rated operational current I_e	A	400	630
Rated short circuit making current	kA	120 at 690 V	100 at 690 V
		120 at 500 V	120 at 500 V
Rated short circuit withstand current	kA	120 at 690 V	100 at 690 V
		120 at 500 V	120 at 500 V
Rated insulation voltage U_i	V	1000	1000
Rated impulse withstand voltage U_{imp}	kV	12	12
Mechanical durability	Number of cycles	1000	1000
Electrical durability		200	200
IP degree of protection	-	30	30
Fuse link size	-	NH1, NH2	NH1, NH2, NH3
Max. power dissipation per fuse link	-	NH1 - 32 W, NH2 - 34 W	NH1 - 32 W, NH2 - 45 W, NH3 - 45 W

Table 6. Versions of ARS 2, 3 evo

Version		Article No.
Fuse switch disconnectors ARS 2 evo – 400 A		
For installation on 185 mm busbar system; SINGLE-POLE SWITCHING – each phase independently		
ARS 2-1-M evo	cable terminals: screw terminals: nuts M12/ bolts M12	63-500700-611
ARS 2-1-V evo	cable terminals: V-terminals: V-clamps 240 mm ²	63-500700-612
ARS 2-1-2V evo	cable terminals: 2V-terminals: double V-clamps 240 mm ²	63-500700-613
For installation on 185 mm busbar system; THREE-POLE SWITCHING – all phases simultaneously		
ARS 2-6-M evo	cable terminals: screw terminals: nuts M12/ bolts M12	63-500700-711
ARS 2-6-V evo	cable terminals: V-terminals: V-clamps 240 mm ²	63-500700-712
ARS 2-6-2V evo	cable terminals: 2V-terminals: double V-clamps 240 mm ²	63-500700-713
Fuse switch disconnectors ARS evo 3 – 630 A		
For installation on 185 mm busbar system; SINGLE-POLE SWITCHING – each phase independently		
ARS 3-1-M evo	cable terminals: screw terminals: nuts M12/ bolts M12	63-500700-621
ARS 3-1-V evo	cable terminals: V-terminals: V-clamps 240 mm ²	63-500700-622
ARS 3-1-2V evo	cable terminals: 2V-terminals: double V-clamps 240 mm ²	63-500700-623
For installation on 185 mm busbar system; THREE-POLE SWITCHING – all phases simultaneously		
ARS 3-6-M evo	cable terminals: screw terminals: nuts M12/ bolts M12	63-500700-721
ARS 3-6-V evo	cable terminals: V-terminals: V-clamps 240 mm ²	63-500700-722
ARS 3-6-2V evo	cable terminals: 2V-terminals: double V-clamps 240 mm ²	63-500700-723
Fuse switch disconnectors ARS evo 210		
For installation on 210 mm busbar system; SINGLE-POLE SWITCHING – each phase independently		
ARS 2-1-M evo 210	cable terminals: screw terminals: nuts M12/ bolts M12	63-500700-614
ARS 2-1-V evo 210	cable terminals: V-terminals: V-clamps 240 mm ²	63-500700-615
ARS 2-1-2V evo 210	cable terminals: 2V-terminals: double V-clamps 240 mm ²	63-500700-616
For installation on 210 mm busbar system; THREE-POLE SWITCHING – all phases simultaneously		
ARS 2-6-M evo	cable terminals: screw terminals: nuts M12/ bolts M12	63-500700-714
ARS 2-6-V evo	cable terminals: V-terminals: V-clamps 240 mm ²	63-500700-715
ARS 2-6-2V evo	cable terminals: 2V-terminals: double V-clamps 240 mm ²	63-500700-716
For installation on 210 mm busbar system; SINGLE-POLE SWITCHING – each phase independently		
ARS 3-1-M evo 210	cable terminals: screw terminals: nuts M12/ bolts M12	63-500700-624
ARS 3-1-V evo 210	cable terminals: V-terminals: V-clamps 240 mm ²	63-500700-625
ARS 3-1-2V evo 210	cable terminals: 2V-terminals: double V-clamps 240 mm ²	63-500700-626
For installation on 210 mm busbar system; THREE-POLE SWITCHING – all phases simultaneously		
ARS 3-6-M evo 210	cable terminals: screw terminals: nuts M12/ bolts M12	63-500700-724
ARS 3-6-V evo 210	cable terminals: V-terminals: V-clamps 240 mm ²	63-500700-725
ARS 3-6-2V evo 210	cable terminals: 2V-terminals: double V-clamps 240 mm ²	63-500700-726

Table 7. Accessories





Description	Article No.	Picture
Extended terminal shroud	51-000331-001	
Terminal shroud for top connection	51-500700-109	
Hooked clamps for installation of ARS 2,3 evo on to busbar system without drilled holes. (set - 3 pcs.). Tightening torque 15 Nm	53-001462-004	
NO - normally open microswitch	1115296318T	
NC - normally closed microswitch	1115296319T	

Table 8. ARS 2, 3 evo terminal clamps

Description	ARS V evo	ARS 2V evo		ARS Mevo
Clamp	V-clamp 35-300SW-B	V-clamp 2/50-300SW-B	V-clamp HS 2/50-240-C*	M-screw M12**
Drawing of clamp				
Cross – section of conductors	V-clamp for direct fixing of conductor with bare end with crosssection of			Lug terminal
	● 35 - 240 mm ²	● 50 - 240 mm ²	● 50 - 240 mm ²	
	◐ 35 - 300 mm ²	◐ 50 - 300 mm ²	◐ 50 - 300 mm ²	
	⊗ 35 - 185 mm ²	⊗ 50 - 185 mm ²	⊗ 50 - 185 mm ²	
	◑ 35 - 240 mm ²	◑ 50 - 240 mm ²	◑ 50 - 240 mm ²	
Tightening torque	30 Nm	30 Nm	40 Nm	56 Nm

For stranded conductors using bare end of conductor/lug terminals is recommended

*) if the fuse switch disconnector with a 2V-type clamp is to be equipped with a steel V-clamp HS 2/50-240-C, it should be included in the order

***) bars of maximum width of 40 mm and maximum thickness of 8 mm can be fixed to M type screw terminals when protective barrier between phases is installed

Apator takes responsibility for technical quality of V-terminals manufactured only by the company. Minimum tightening torque M12 screw for screws fixing

fuse switch disconnector to busbar system – 32 Nm, recommended tightening torque for screws and nuts with property class 8.8 – 56 Nm.

In ARS 3 V evo disconnectors, V-type connection terminals and double V-type terminals can be used interchangeably.



smartARS pro

vertical fuse switch disconnectors

smartARS-X pro

Vertical fuse switch disconnecter with fuse monitoring module



smartARS 2-6-V-X pro

Applications

The fuse switch disconnecter can be equipped with a device that allows indication of the current state of the fuse links. Information about fuse link burnout, correct operation or power failure is indicated by diode light signal or can be transferred to any automation protection system, through the relay contacts.

Description of operation of the fuse monitoring module

- diode is green – correct operation, fuse link works correctly
- diode is red – failure, fuse link burnout
- diode is red; blinking – phase shift (another phase voltage was detected at the fuse link outgoing contact)
- diodes off – no power supply

Nominal parameters

- Voltage value for cable test 2,5 kV DC
- Minimum operating voltage 200 V
- Maximum operating voltage 450 V
- U_{imp} impulse withstand voltage with operated fuse link 4 kV
- U_{imp} between phases 4 kV
- U_{imp} between main circuit / relay contacts 3,5 kV
- Temperature range -40...+85°C
- Rated insulation voltage U_i 1000 V

Table 9. Technical data

Parameters		smartARS 00-X pro	smartARS 2-X pro	smartARS 3-X pro
Rated thermal current I_{th} with knife-blade fuses	A	160	250 (NH1), 400 (NH2)	630
Rated thermal current I_{th} with knife links	A	210	600	750
Rated insulation voltage U_n	V	500	500	500
Rated insulation voltage	-	AC-22B	AC-22B	AC-22B
Rated switching voltage U_e	V	690	500	500
Rated switching current I_e	A	160	250 (NH1), 400 (NH2)	630
Rated short circuit making current	$U_e=690$ V	80	100	80
	$U_e=500$ V	100	120	120
Rated short circuit withstand current	$U_e=690$ V	80	100	100
	$U_e=500$ V	100	120	100
Rated insulation voltage U_i	V	1000	1000	1000
Rated impulse withstand voltage U_{imp}	kV	8	12	12
Rated frequency	Hz	50-60	50-60	50-60
Mechanical durability	number of cycles	1600	1000	1000
Electrical durability	connecting cycles	200	200	200
IP degree of protection	-	30	30	30
Size of fuse links	-	00	1,2	3

OPERATING CONDITIONS

- to be installed in the room free of any dust, aggressive or explosive gases,
- altitude up to 2000 meters above sea level,
- ambient temperature from -25°C to +55°C,

FUSE SWITCH DISCONNECTOR WITH LATERAL BUSBAR TERMINALS

smartARS 00-X-E pro – connection diagram

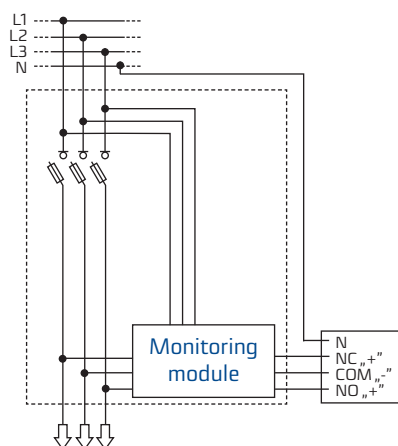

Fuse monitoring module:

- information about the blown fuse links
- information about correct work
- version with communication output, NO NC contact

Description of operation of the fuse monitoring module

- diode is green - correct operation, fuse link works correctly
- diode is red - failure, fuse link operated
- diode is red; blinking - phase shift (another phase voltage was detected at the fuse link outgoing contact)
- diodes off - module switched off / no power supply

smartARS 2-X pro, smartARS 3-X pro

– connection diagram

Module outputs:

Rated current 100 mA

Maximum switching voltage 50 V DC

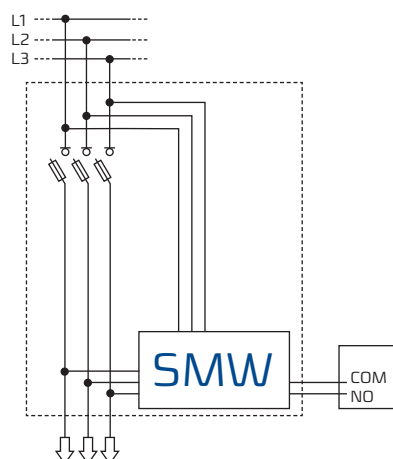

smartARS 00-X pro

– connection diagram (version with a switch)

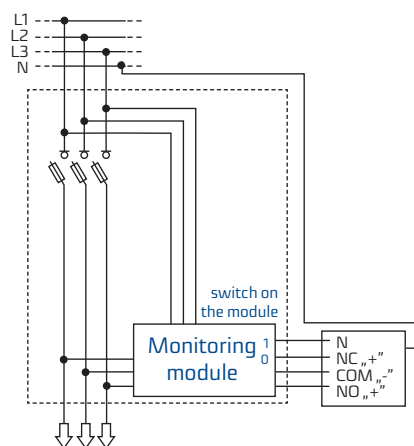

The module is equipped with a single-pole switch responsible for fuse monitoring module:

1 – module turned on

0 – module switched off

Signaling of blown fuse - **output communication NO, NC contact**

Switch operation states

0 – the device is in the reserve field

0 – the switch disconnecter is without fuse links

1 – basic operating status of a switch disconnecter with fuse links

Fuse state (resultant)	NO output	NC output	diode colour
Correct operation	„0” (0 V)	„1” (24 V)	green
Failure	„1” (24 V)	„0” (0 V)	red

The transport outputs can be supplied with a DC voltage of up to 50 V with current limitation to max. 100 mA

SMW module

- phase-to-phase powered module
- communication output: normally open NO contact

Fuse state (resultant)	NO output	diode colour
Correct operation	„0”	green
Failure	„1”	red

Table 10. smartARS 00-X pro, smartARS 2-X pro, smartARS 3-X pro terminal clamps

Description	smartARS 00-X pro	
Clamp	V-clamp 25-150 SW	HM 10-120
Drawing of clamp		
Cross-section of conductors	re ● 16 mm ² - 95 mm ²	re ● 10 mm ² - 70 mm ²
	se ◆ 25 mm ² - 150 mm ²	se ◆ 25 mm ² - 120 mm ²
	rm ⊗ 16 mm ² - 95 mm ²	rm ⊗ 10 mm ² - 70 mm ²
	sm ⊕ 25 mm ² - 150 mm ²	sm ⊕ 25 mm ² - 95 mm ²
Tightening torque	20 Nm*	15 Nm*

For stranded conductors using cable ferrules is recommended.

*) using tension wrench is recommended

**) if the fuse switch disconnecter with a V-type clamp is to be equipped with a steel V-clamp HM 10-120, it should be included in the order Apator takes responsibility for technical quality of V-terminals manufactured only by the company.

Description	smartARS 2-x-V-X pro smartARS 3-x-V-X pro	smartARS 2-x-2V-X pro smartARS 3-x-2V-X pro	smartARS 2-x-2V-X pro smartARS 3-x-2V-X pro	smartARS 2-x-M-X pro smartARS 3-x-M-X pro
Clamp	V-clamp 35-300SW-B	V-clamp 2/50-300SW-B	V-clamp HS 2/50-240-C*	M-screw M12**
Drawing of clamp				
Cross-section of conductors	V-clamp for direct fixing of conductor of bare end with cross-section of:			
	35 - 185 mm ² ⊗	35 - 240 mm ² ●	50 - 185 mm ² ⊗	50 - 240 mm ² ●
	35 - 240 mm ² ⊕	35 - 300 mm ² ◆	50 - 240 mm ² ⊕	50 - 300 mm ² ◆
Tightening torque	30 Nm	30 Nm	40 Nm	56 Nm

For stranded conductors using cable ferrules is recommended.

*) fuse switch disconnectors with 2V-terminals are equipped with steel V-clamp HS 2/35-240-C on request

**) Bars of maximum width of 40 mm and maximum thickness of 8 mm can be fixed to M type screw terminals when protective barrier between phases is installed

Apator takes responsibility for technical quality of V-terminals manufactured only by the company.

Minimum tightening torque (M12 screw) for screw fixing fuse switch disconnecter to busbar system – 32 Nm, recommended tightening torque for screws and nuts with property class 8.8 – 56 Nm.

Table 11. Versions with electronic fuse monitoring module (SMW version)

Version	Weight	Article no.
Disconnectors smartARS 00-X pro - 160 A		
Installation on to 185 mm busbar system; ONE-POLE SWITCHING - each phase independently		
smartARS 00-1-V-X-E pro cable terminal; V-terminals; V-clamp 25-150 SW + hook clamps	3,1 kg	63-001606-201
for installation on 185 mm busbar system, THREE POLE SWITCHING - all phases simultaneously		
smartARS 00-3-V-X pro cable terminal; V-terminals; V-clamp 25-150 SW	3,1 kg	63-001358-021
Disconnectors smartARS 2-X pro - 400 A		
for installation on 185 mm busbar system, THREE POLE SWITCHING - all phases simultaneously		
smartARS 2-1-V-X pro cable terminal; V-terminals; V-clamp 240 mm ²	5,9 kg	63-200400-461
smartARS 2-1-M-X pro cable terminals: pressed nuts M12	5,8 kg	63-200400-463
smartARS 2-1-2V-X pro cable terminal; 2V-terminals; double V-clamps 240 mm ²	6,5 kg	63-200400-465
for installation on 185 mm busbar system, THREE POLE SWITCHING - all phases simultaneously		
smartARS 2-6-V-X pro cable terminal; V-terminals; V-clamp 240 mm ²	5,9 kg	63-200401-461
smartARS 2-6-M-X pro cable terminals: pressed nuts M12	5,8 kg	63-200401-463
smartARS 2-6-2V-X pro cable terminal; 2V-terminals; double V-clamps 240 mm ²	6,5 kg	63-200401-465
Disconnectors smartARS 3-X pro - 630 A		
Installation on to 185 mm busbar system; ONE-POLE SWITCHING - each phase independently		
smartARS 3-1-V-X pro cable terminal; V-terminals; V-clamp 240 mm ²	6,7 kg	63-200400-462
smartARS 3-1-M-X pro cable terminals: pressed nuts M12	6,6 kg	63-200400-464
smartARS 3-1-2V-X pro cable terminal; 2V-terminals; double V-clamps 240 mm ²	7,3 kg	63-200400-466
for installation on 185 mm busbar system, THREE POLE SWITCHING - all phases simultaneously		
smartARS 3-6-V-X pro cable terminal; V-terminals; V-clamp 240 mm ²	6,7 kg	63-200401-462
smartARS 3-6-M-X pro cable terminals: pressed nuts M12	6,6 kg	63-200401-464
smartARS 3-6-2V-X pro cable terminal; 2V-terminals; double V-clamps 240 mm ²	7,3 kg	63-200401-466

smartARS-Xt pro

Vertical fuse switch disconnecter with fuse monitoring module



smartARS 2-6-V-Xt pro

Module outputs:

Communication protocol RS 485
MODBUS communication protocol

Applications

The fuse switch disconnecter can be equipped with device that allows indication of the current state of the fuse links. Information about fuse link burnout, correct operation or power failure are indicated by diode light signal or can be transferred to an automation protection system, directly from the module through the RS485 communication module.

Description of operation of the fuse monitoring module

- diode is green - correct operation, all fuse links work correctly
- diode is red - failure, fuse link burnout
- diode is red; blinking - phase shift (another phase voltage was detected at the fuse link outgoing contact)
- diodes off - module switched off / no power supply

Nominal parameters

- Voltage value for cable test 2,5 kV DC
- Minimum operating voltage 200 V
- Maximum operating voltage 690 V
- U_{imp} impulse withstand voltage with operated fuse link 4 kV
- U_{imp} between phases 4 kV
- U_{imp} between main circuit / relay contacts 3,5 kV
- Temperature range -40...+85°C
- Rated insulation voltage U_i 1000 V

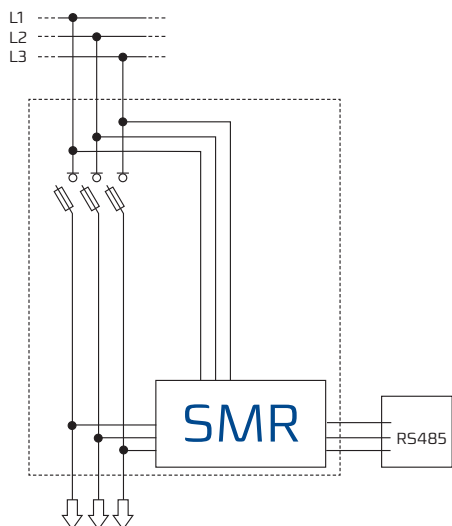

Moduł SMR

- communication output
- RS485 connector (communication using MODBUS protocol)

Table 12. Technical data

Parametr		smartARS 2-XT pro	smartARS 3-XT pro
Rated thermal current I_{th} with knife-blade fuses	A	250 (NH1), 400 (NH2)	630
Rated thermal current I_{th} with knife links	A	600	750
Rated insulation voltage U_n	V	500	500
Rated insulation voltage	-	AC-22B	AC-22B
Rated switching voltage U_e	V	500	500
Rated switching current I_e	A	250 (NH1), 400 (NH2)	630
Rated short circuit making current	$U_e=690 V$ $U_e=500 V$ kA	100 120	80 120
Rated short circuit withstand current	$U_e=690 V$ $U_e=500 V$ kA	100 120	100
Rated insulation voltage U_i	V	1000	1000
Rated impulse withstand voltage U_{imp}	kV	12	12
Rated frequency	Hz	50-60	50-60
Mechanical durability	number of cycles	1000	1000
Electrical durability	connecting cycles	200	200
IP degree of protection	-	30	30
Size of fuse links	-	1,2	3

Table 13. smartARS 2-XT pro, smartARS 3-XT pro terminal clamps

Description	smartARS 2-x-V-XT pro smartARS 3-x-V-XT pro	smartARS 2-x-2V-XT pro smartARS 3-x-2V-XT pro	smartARS 2-x-2V-XT pro smartARS 3-x-2V-XT pro	smartARS 2-x-M-XT pro smartARS 3-x-M-XT pro
	V-clamp 35-300SW-B	V-clamp 2/50-300SW-B	V-clamp HS 2/50-240-C*	M-screw M12**
Drawing of clamp				
Cross-section of conductors	V-clamp for direct fixing of conductor of bare end with cross-section of:			Lug terminal
	35 - 185 mm ² 35 - 240 mm ²	50 - 185 mm ² 50 - 240 mm ²	50 - 185 mm ² 50 - 240 mm ²	
	35 - 240 mm ² 35 - 300 mm ²	50 - 240 mm ² 50 - 300 mm ²	50 - 240 mm ² 50 - 300 mm ²	
Tightening torque	30 Nm	30 Nm	40 Nm	56 Nm

For stranded conductors using cable ferrules is recommended.

*) fuse switch disconnectors with 2V-terminals are equipped with steel V-clamp HS 2/35-240-C on request

**) Bars of maximum width of 40 mm and maximum thickness of 8 mm can be fixed to M type screw terminals when protective barrier between phases is installed

Apator takes responsibility for technical quality of V-terminals manufactured only by the company.

Minimum tightening torque (M12 screw) for screw fixing fuse switch disconnector to busbar system – 32 Nm, recommended tightening torque for screws and nuts with property class 8.8 – 56 Nm.

Table 14. Versions with electronic fuse monitoring module (SMR version)

Version	Weight	Article no.
Disconnectors smartARS 2 pro – 400A		
Installation on to 185 mm busbar system; ONE-POLE SWITCHING - each phase independently		
smartARS 2-1-V-XT pro	cable terminal; V-terminals; V-clamp 240 mm ²	5,9 kg 63-200400-561
smartARS 2-1-M-XT pro	cable terminals: pressed nuts M12	5,8 kg 63-200400-563
smartARS 2-1-2V-XT pro	cable terminal; 2V-terminals; double V-clamps 240 mm ²	6,5 kg 63-200400-565
for installation on 185 mm busbar system, THREE POLE SWITCHING - all phases simultaneously		
smartARS 2-6-V-XT pro	cable terminal; V-terminals; V-clamp 240 mm ²	5,9 kg 63-200401-561
smartARS 2-6-M-XT pro	cable terminals: pressed nuts M12	5,8 kg 63-200401-563
smartARS 2-6-2V-XT pro	cable terminal; 2V-terminals; double V-clamps 240 mm ²	6,5 kg 63-200401-565
Disconnectors smartARS 3 pro - 630 A		
Installation on to 185 mm busbar system; ONE-POLE SWITCHING - each phase independently		
smartARS 3-1-V-XT pro	cable terminal; V-terminals; V-clamp 240 mm ²	6,7 kg 63-200400-562
smartARS 3-1-M-XT pro	cable terminals: pressed nuts M12	6,6 kg 63-200400-564
smartARS 3-1-2V-XT pro	cable terminal; 2V-terminals; double V-clamps 240 mm ²	7,3 kg 63-200400-566
for installation on 185 mm busbar system, THREE POLE SWITCHING - all phases simultaneously		
smartARS 3-6-V-XT pro	cable terminal; V-terminals; V-clamp 240 mm ²	6,7 kg 63-200401-562
smartARS 3-6-M-XT pro	cable terminals: pressed nuts M12	6,6 kg 63-200401-564
smartARS 3-6-2V-XT pro	cable terminal; 2V-terminals; double V-clamps 240 mm ²	7,3 kg 63-200401-566

Vertical fuse switch disconnector smartARS P pro with current transformers

Disconnectors adjusted to current metering

smartARS P pro



smartARS 2-6-M P pro



smartARS 2-6-M P pro



smartARS 3-6-V SMP pro

Table 15. Technical data

Parameters		smartARS 2 P pro		smartARS 3 P pro		
		250(NH1), 400(NH2)	600	AC-22B	AC-23B	AC-21B
Rated thermal current I _{th} with knife-blade fuses	A	250(NH1), 400(NH2)	630			
Rated thermal current I _{th} with knife links	A	600	750			
Rated insulation voltage U _n	V	690	690			
Utilisation category	-	AC-22B	AC-23B	AC-23B	AC-22B	AC-21B
Rated switching voltage U _e	V	690	400	400	500	690
Rated switching current I _e	A	250(NH1), 400(NH2)	630			
Rated short circuit making current	U _e =690 V	100	80			
	U _e =500 V	120	120			
Rated short circuit withstand current	U _e =690 V	100	100			
	U _e =500 V	120	100			
Rated insulation voltage U _i	V	1000	1000			
Rated impulse withstand voltage U _{imp}	kV	12	12			
Rated frequency	Hz	50-60	50-60			
Mechanical durability	number of cycles	1000	1000			
Electrical durability	connecting cycles	200	200			
IP degree of protection	-	30	30			
Size of fuse links	-	1,2	3			

Transformers used for current metering in **smartARS P pro** disconnectors 160 A, 400 A and 630 A are incorporated in the base of the device and do not increase its size, it makes it possible to save space in a switchgear a cabinet.

Technical parameters of the applied transformers:

- in smartARS 00 P pro - 150/5/0,5S/2,5 VA
- in smartARS 2 P pro, smartARS 3 P pro – 100/5/1/2,5 VA; 150/5/0,5/2,5 VA; 200/5/0,5/2,5 VA; 250/5/0,5/2,5 VA; 300/5/0,5 s/2,5 VA; 400/5/0,5 s/2,5 VA; 500/5/0,5 s/2,5 VA; 600/5/0,5 s/2,5 VA

Secondary current = 1 A on request

Disconnectors have contact terminals enabling connecting signal cables from transformers.

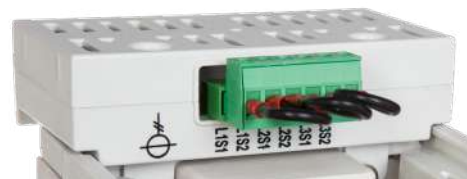

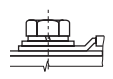
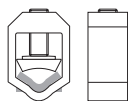

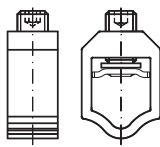

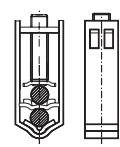

Table 16. Versions

Version		Weight	Article no.
Disconnectors smartARS 00 P pro - 160A			
for installation on 185 mm busbar system, THREE POLE SWITCHING - all phases simultaneously			
smartARS 00-3-V P pro	Cable terminal; V-terminals; V-clamp 25-150 SW	3,1 kg	63-001415-301
smartARS 00-3-M P pro	Cable terminals: M8 screw terminals	3 kg	63-001415-302
Disconnectors smartARS 2 P pro – 400 A			
Installation on to 185 mm busbar system; ONE-POLE SWITCHING - each phase independently			
smartARS 2-1-V P pro	Cable terminal; V-terminals; V-clamp 240 mm ²	6,8	63-001340-301
smartARS 2-1-M P pro	Cable terminals: pressed nuts M12	6,7	63-001340-303
smartARS 2-1-2V P pro	Cable terminal; 2V-terminals; double V-clamps 240 mm ²	7,4	63-001340-305
for installation on 185 mm busbar system, THREE POLE SWITCHING - all phases simultaneously			
smartARS 2-6-V P pro	Cable terminal; V-terminals; V-clamp 240 mm ²	6,8	63-001341-301
smartARS 2-6-M P pro	Cable terminals: pressed nuts M12	6,7	63-001341-303
smartARS 2-6-2V P pro	Cable terminal; 2V-terminals; double V-clamps 240 mm ²	7,4	63-001341-305
Disconnectors smartARS 3 P pro – 630 A			
Installation on to 185 mm busbar system; ONE-POLE SWITCHING - each phase independently			
smartARS 3-1-V P pro	Cable terminal; V-terminals; V-clamp 240 mm ²	7,6	63-001340-302
smartARS 3-1-M P pro	Cable terminals: pressed nuts M12	7,5	63-001340-304
smartARS 3-1-2V P pro	Cable terminal; 2V-terminals; double V-clamps 240 mm ²	8,2	63-001340-306
for installation on 185 mm busbar system, THREE POLE SWITCHING - all phases simultaneously			
smartARS 3-6-V P pro	Cable terminal; V-terminals; V-clamp 240 mm ²	7,6	63-001341-302
smartARS 3-6-M P pro	Cable terminals: pressed nuts M12	7,5	63-001341-304
smartARS 3-6-2V P pro	Cable terminal; 2V-terminals; double V-clamps 240 mm ²	8,2	63-001341-306

Table 17. smartARS 2 P pro and smartARS 3 P pro terminal clamps

Description		smartARS 00 P pro	
Clamp	M8 screw*	V-clamp 25-150 SW B	
Picture of clamp			
Drawing of clamp			
Cross-section of conductors	Conductor with lug terminal max. 185 mm ²	re ● 16 mm ² - 95 mm ²	rm ● 16 mm ² - 95 mm ²
		se ◐ 25 mm ² - 150 mm ²	sm ◐ 25 mm ² - 120 mm ²
Tightening torque	12 Nm**	20 Nm**	

For stranded conductors using cable ferrules is recommended
 *) bars of maximum width of 20 mm and maximum thickness of 5 mm can be fixed to M type screw terminals
 **) using tension wrench is recommended

Description	smartARS 2-x-V P pro smartARS 3-x-V P pro	smartARS 2-x-2V P pro smartARS 3-x-2V P pro	smartARS 2-x-2V P pro smartARS 3-x-2V P pro	smartARS 2-x-M P pro smartARS 3-x-M P pro			
Clamp	V-clamp 35-300SW-B	V-clamp 2/50-300SW-B	V-clamp HS 2/50-240-C*	M-screw M12**			
Drawing of clamp							
Cross-section of conductors	V-clamp for direct fixing of conductor of bare end with cross-section of:				Lug terminal		
	35 - 185 mm ² ◐	35 - 240 mm ² ●	50 - 185 mm ² ◐	50 - 240 mm ² ●		50 - 185 mm ² ◐	50 - 240 mm ² ●
Tightening torque	30 Nm		30 Nm		40 Nm	56 Nm	

For stranded conductors using cable ferrules is recommended.

*) fuse switch disconnectors with 2V-terminals are equipped with steel V-clamp HS 2/35-240-C on request

***) Bars of maximum width of 40 mm and maximum thickness of 8 mm can be fixed to M type screw terminals when protective barrier between phases is installed
 Apator takes responsibility for technical quality of V-terminals manufactured only by the company.

Minimum tightening torque (M12 screw) for screw fixing fuse switch disconnector to busbar system – 32 Nm, recommended tightening torque for screws and nuts with property class 8.8 – 56 Nm.

SmartARS pro-PV AC 800 V

A safe step into the future with Apator



smartARS 00
pro-PV



smartARS 2
pro-PV



smartARS 3
pro-PV



The new switch fuse disconnecter smartARS in the AC800V product line is a device which has been developed to meet the needs and requirements of the future.

Solar power systems and a new generation of inverters are assembled on AC800V correctly and safely under load. In the future AC800V will be extended by the smartARS family; moreover, it can be modified to facilitate the digitization of the energy transition.

High-quality materials and years of experience of Apator Group in the NH disconnectors sector ensure excellent cost-benefit ratio.

Table 18. Technical data

Parameter			smartARS 00 pro-PV	smartARS 2 pro-PV	smartARS 3 pro-PV
For NH fuse-links acc. to DIN VDE 0636-2	Size		00	1, 2	3
Rated operational voltage	U_e	V	AC800	AC800	AC800
Rated operational current	I_e	A	80	200	400
Conv. free air thermal current with fuse-links	I_{th}	A	80	200	400
Rated frequency	f	Hz	50 - 60	50 - 60	50 - 60
Rated insulation voltage	U_i	V	AC1000	AC1000	AC1000
Rated impulse withstand voltage	U_{imp}	kA	8	12	12
Utilization category			AC21B 80 A/ 800 V	AC21B 200 A/800 V	AC21B 400 A/ 800 V
Fuse protected short circuit withstand	kA		100 ¹⁾ 10 ²⁾	120 ¹⁾ 10 ²⁾	120 ¹⁾ 10 ²⁾
Fuse protected short circuit making	kA		100 ¹⁾ 10 ²⁾	120 ¹⁾ 10 ²⁾	120 ¹⁾ 10 ²⁾
Max. permis. power loss per fuse-link	Pa	W	11	21	41
Pollution degree			3	3	3
IP degree of protection	IP		30		

¹⁾ with NH gG fuse links (500 V)

²⁾ with NH gS/gRL fuse-links (800 V)

Table 19. Versions

Version		Weight	Article No.
for installation on to 185 mm busbar system, three pole switching - all phases simultaneously			
smartARS 00-3 pro-PV	cable terminals: bridge terminals with bridge clamps (S) 4-70 mm ² , screw terminals with M8 screws	2,5 kg	63-073821-001
smartARS 00-3-V pro-PV	cable terminals: V-terminals with V-clamps 25-150 SW	2,6 kg	63-073821-002
smartARS 2-6-V pro-PV	cable terminals: V-terminals with V-clamps 240 mm ²	5,8 kg	63-073822-001
smartARS 3-6-V pro-PV	cable terminals: V-terminals with V-clamps 240 mm ²	6,6 kg	63-073822-002
smartARS 2-6-M pro-PV	cable terminals: screw terminals with pressed nuts M12	5,7 kg	63-073822-003
smartARS 3-6-M pro-PV	cable terminals: screw terminals with pressed nuts M12	6,5 kg	63-073822-004
smartARS 2-6-2V pro-PV	cable terminals: 2V-terminals with double V-clamps 240 mm ²	6,4 kg	63-073822-005
smartARS 3-6-2V pro-PV	cable terminals: 2V-terminals with double V-clamps 240 mm ²	7,2 kg	63-073822-006

APATOR recommends SIBA NH fuses for best protection of the new generation of PV String Inverters

The new series of SIBA NH fuses with operating class: gRL/gS has been developed for the line protection of the new PV String Inverters. Due to the use of special geometries of melting elements, in comparison to the conventional line protection fuses (operating class: gG) a considerably faster operation at short circuits and thus optimum protection of the inverters has been realized. In the space-saving NH standard designs, the fuse links achieve a maximum breaking capacity of 120 kA with a test voltage of 880 V. The power losses of series NH1, NH2 and NH3 have been designed for the respective maximum power acceptance of the corresponding NH fuse bases. SIBA article numbers: 20 309 34.80 NH00 AC 800V 80A 120 kA20 311 34. Current NH1 AC 800V 100 – 200A 120 kA20 312 34. Current NH2 AC 800V 160 – 200A 120 kA20 313 34. Current NH3 AC 800V 200 – 400A 120 kA

Table 20. smartARS 00 pro-PV terminal clamps

Description	smartARS 00 pro-PV			
Clamp	S-bridge clamp 2 x M5 x 25	M8 screw*	V-clamp 25-150 SW B	HM 10-120
Picture of clamp				
Drawing of clamp				
Cross –section of conductors	4 - 70 mm ²	Lug terminal max 185 mm ²	re ● 16 mm ² - 95 mm ²	re ● 10 mm ² - 70 mm ²
			se ◆ 25 mm ² - 150 mm ²	se ◆ 25 mm ² - 120 mm ²
			rm ⊗ 16 mm ² - 95 mm ²	rm ⊗ 10 mm ² - 70 mm ²
			sm ⊕ 25 mm ² - 120 mm ²	sm ⊕ 25 mm ² - 95 mm ²
Tightening torque	3 Nm**	12 Nm**	20 Nm**	15 Nm**

For stranded conductors using cable ferrules is recommended

*) bars of maximum width of 20 mm and maximum thickness of 5 mm can be fixed to M type screw terminals

***) using tension wrench is recommended

****) fuse switch disconnectors with V-terminals are equipped with steel V-clamp HM 10-120 on request

Apator takes responsibility for technical quality of V-terminals manufactured only by the company. Minimum tightening torque (M8 screw) for screws fixing fuse switch disconnector to busbar system – 12 Nm, recommended tightening torque for screws and nuts with property class 8.8 – 21 Nm.

Table 21. smartARS 2,3 pro-PV terminal clamps

Description	smartARS 2,3-x-V pro-PV		smartARS 2,3-x-2V pro-PV		smartARS 2,3-x-2V pro-PV		smartARS 2,3-x-M pro-PV
Clamp	V-clamp 35-300SW-B		V-clamp 2/50-300SW-B		V-clamp HS 2/50-240-C*		M-screw M12**
Picture of clamp							
Cross – section of conductors	V-clamp for direct fixing of conductor with bare end with crosssection of						Lug terminal
	35 - 185 mm ² ⊗	35 - 240 mm ² ●	50 - 185 mm ² ⊗	50 - 240 mm ² ●	50 - 185 mm ² ⊗	50 - 240 mm ² ●	
	35 - 240 mm ² ⊕	35 - 300 mm ² ◆	50 - 240 mm ² ⊕	50 - 300 mm ² ◆	50 - 240 mm ² ⊕	50 - 300 mm ² ◆	
Tightening torque	30 Nm		30 Nm		40 Nm		56 Nm

For stranded conductors using cable ferrules is recommended

*) if the fuse switch disconnector with a 2V-type clamp is to be equipped with a steel V-clamp HS 2/50-240-C, it should be included in the order

***) bars of maximum width of 40 mm and maximum thickness of 8 mm can be fixed to M type screw terminals when protective barrier between phases is installed

Apator takes responsibility for technical quality of V-terminals manufactured only by the company. Minimum tightening torque (M12 screw) for screws fixing fuse switch disconnector to busbar system – 32 Nm, recommended tightening torque for screws and nuts with property class 8.8 – 56 Nm.



smartARS pro disconnectors

on IP20 busbar

Hook adapter for assembling smartARS pro disconnectors on IP20 busbar

smartARS 00 pro disconnectors enable changing the drain direction from the top as in the user manual.



smartARS 2,3 pro disconnectors can be used with a hook adapter for assembling disconnectors on IP20 busbar. To change the drain direction from the top, rotate the hook and plate by 180° as in the user manual.



Table 22. Versions

Label	Description	Catalogue number
smartARS 00-1-V-W-H pro	cable terminal: V-terminals: V-clamp 25-150 SW	63-106562-011
smartARS 00-1-W-H pro	cable terminal: bridge clamps (S) 4-70 mm and M8-screw	63-106562-012
smartARS 00-3-V-W-H pro	cable terminal: V-terminals: V-clamp 25-150 SW	63-106562-021
smartARS 00-3-W-H pro	cable terminal: bridge clamps (S) 4-70 mm and M8-screw	63-106562-022
smartARS 2-1-V-H pro	cable terminal: V-terminals: V-clamp 240 mm ²	63-106562-211
smartARS 2-1-M-H pro	cable terminals: pressed nuts M12	63-106562-213
smartARS 2-1-2V-H pro	cable terminals: 2V-terminals: double V-clampos 240 mm ²	63-106562-215
smartARS 00-3-2T-W-H pro	cable terminal: double frame clamp 4-95 mm ²	63-106562-027
smartARS 2-6-V-H pro	cable terminal: V-terminals: V-clamp 240 mm ²	63-106562-221
smartARS 2-6-M-H pro	cable terminals: pressed nuts M12	63-106562-223
smartARS 2-6-2V-H pro	cable terminals: 2V-terminals: double V-clampos 240mm ²	63-106562-225
smartARS 3-1-V-H pro	cable terminal: V-terminals: V-clamp 240 mm ²	63-106562-312
smartARS 3-1-M-H pro	cable terminals: pressed nuts M12	63-106562-314
smartARS 3-1-2V-H pro	cable terminals: 2V-terminals: double V-clampos 240 mm ²	63-106562-316
smartARS 3-6-V-H pro	cable terminal: V-terminals: V-clamp 240 mm ²	63-106562-322
smartARS 3-6-M-H pro	cable terminals: pressed nuts M12	63-106562-324
smartARS 3-6-2V-H pro	cable terminals: 2V-terminals: double V-clampos 240 mm ²	63-106562-326

Table 23. Technical data

Parameter		smartARS 00 pro	smartARS 2 pro	smartARS 3 pro			
Rated thermal current $I_{th}=I_n$	A	160	250 (NH1), 400 (NH2)	630			
Rated thermal current $I_{th}=I_n$ with solid links	A	210	600	750			
Rated voltage U_n	V	690	690	690			
Utilization category	-	AC-22B	AC-23B	AC-23B	AC-23B	AC-22B	AC-21B
		690	400				
Rated switching voltage U_e	V	690	690	400	400	500	690
Rated switching current I_e	A	160	250 (NH1), 400 (NH2)	630			
Rated short circuit making current	690 V	kA	80	100	80		
	500 V		100	120	120		
Rated short circuit withstand current	690 V	kA	80	100	100		
	500 V		100	120	120		
Rated insulation voltage U_i	V	1000	1000	1000			
Rated impulse withstand voltage U_{imp}	kV	12	12	12			
Rated frequency	Hz	50-60	50-60	50-60			
Mechanical durability	Number of cycles	1600	1000	1000			
Electrical durability		200	200	200			
IP degree of protection	-	30	30	30			
Fuse links size	-	00	1,2	3			

OPERATING CONDITIONS

- to be installed in the room free of any dust, aggressive or explosive gases,
- altitude up to 2000 meters above sea level,
- ambient temperature from -25°C to +55°C,

Table 24. smartARS 00 pro terminal clamps

Description	smartARS 00 pro				ARS 00 2T evo
Clamp	S-bridge clamp 2 x M5 x 25	M8 screw*	V-clamp 25-150 SW B	HM 10-120	double frame
Picture of clamp					
Drawing of clamp					
Cross –section of conductors	4 - 70 mm ²	Lug terminal max 185 mm ²	re ● 16 mm ² - 95 mm ² se ◆ 25 mm ² - 150 mm ² rm ⊗ 16 mm ² - 95 mm ² sm ⊕ 25 mm ² - 120 mm ²	re ● 10 mm ² - 70 mm ² se ◆ 25 mm ² - 120 mm ² rm ⊗ 10 mm ² - 70 mm ² sm ⊕ 25 mm ² - 95 mm ²	4 ÷ 95 mm ²
Tightening torque	3 Nm**	12 Nm**	20 Nm**	15 Nm**	5 Nm**

For stranded conductors using cable ferrules is recommended

*) bars of maximum width of 20 mm and maximum thickness of 5 mm can be fixed to M type screw terminals

***) using tension wrench is recommended

***) fuse switch disconnectors with V-terminals are equipped with steel V-clamp HM 10-120 on request

Apator takes responsibility for technical quality of V-terminals manufactured only by the company. Minimum tightening torque (M8 screw) for screws fixing fuse switch disconnector to busbar system – 12 Nm, recommended tightening torque for screws and nuts with property class 8.8 – 21 Nm.

Table 25. smartARS 2,3 pro terminal clamps

Description	smartARS 2-x-V pro smartARS 3-x-V pro	smartARS 2-x-2V pro smartARS 3-x-2V pro	smartARS 2-x-2V pro smartARS 3-x-2V pro	smartARS 2-x-M pro smartARS 3-x-M pro
Clamp	V-clamp 35-300SW-B	V-clamp 2/50-300SW-B	V-clamp HS 2/50-240-C*	M-screw M12**
Picture of clamp				
Cross –section of conductors	V-clamp for direct fixing of conductor with bare end with crosssection of			
	35 - 185 mm ² ⊗ 35 - 240 mm ² ⊕	35 - 240 mm ² ● 35 - 300 mm ² ◆	50 - 185 mm ² ⊗ 50 - 240 mm ² ⊕	50 - 240 mm ² ● 50 - 300 mm ² ◆
Tightening torque	30 Nm	30 Nm	40 Nm	56 Nm

For stranded conductors using cable ferrules is recommended

*) if the fuse switch disconnector with a 2V-type clamp is to be equipped with a steel V-clamp HS 2/50-240-C, it should be included in the order

***) bars of maximum width of 40 mm and maximum thickness of 8 mm can be fixed to M type screw terminals when protective barrier between phases is installed Apator takes responsibility for technical quality of V-terminals manufactured only by the company. Minimum tightening torque (M12 screw) for screws fixing fuse switch disconnector to busbar system – 32 Nm, recommended tightening torque for screws and nuts with property class 8.8 – 56 Nm.

Table 26. Accessories

Label	Description	Tightening torque	Catalogue number
Hook adapter	Hook adapter for smartARS 2,3 pro disconnectors for assembling the disconnector on IP20 busbar	15 Nm	53-106562-180



ARS pro

vertical fuse switch disconnectors

- fibre glass extra strenghtened, self extinguishing
- thermoplastics of V0 flammability class
- double clearance between open contacts
- arc chambers with deionization plates over every contact
- reversibility - top/bottom cable terminal connection
- wide range of accesories

GENERAL INFORMATION

ARS pro vertical fuse switch disconnectors are designed for distribution of electricity and protection against short circuits and overloads in three phase alternative current circuits. They are intended for direct installation on horizontal or vertical busbar systems.

ARS pro fuse switch disconnectors meet technical requirements of electricity boards and are conforming to EN 60947-1, EN 60947-3, IEC 60947-1, IEC 60947-3 standards. **ARS pro** fuse switch disconnectors are dedicated for applications which require reliability and safety like low voltage distribution boards installed in transformer substations, industrial low voltage distribution boards and cable cabinets.

Removal of the fuse links provides clearly noticeable, large isolating distances in the circuit.

ARS pro fuse switch disconnectors are designed to perform the following functions:

- protection,
- energy distribution,
- earthing,
- switching,
- touch protection.

CONSTRUCTION

ARS pro fuse switch disconnectors are manufactured in two versions:

- one pole switching (separately each pole),
- three pole switching (three poles at the same time).

ARS pro fuse switch disconnectors have manually operated handle therefore making and breaking operations should be done with determined movement.

ARS pro fuse switch disconnectors are available in following sizes (according to rated current): 00 (160 A) also available are versions 910 A and 1250 A.

ARS pro fuse switch disconnectors (size 2-400 A; 910 A; 1250 A) are designed for installation on 185 mm busbar system. **ARS 00/100 mm pro** fuse switch disconnector (size 00) is designed for installation on 100 mm busbar system.

By using the adapter, it is possible to mount the **ARS 00 / 100 mm pro** switch disconnector on busbar system with a spacing of 185 mm.

All plastic parts of fuse switch disconnector **ARS pro** are made of halogen free, fibre glass strengthened, self extinguishing materials. Thanks to the application of flame retardants the highest flammability class – V0 was achieved. Fuse switch disconnectors made from such thermoplastics self-extinguish in specified time after ignition source is removed. Also dripping of flaming parts of plastic does not occur.

Silver plated contacts provide low power loss. Depending on clamp type, **ARS pro** fuse switch disconnectors enable user to connect circular or sector-shaped conductors with bare ends or conductors with lug terminals. Arc chambers equipped with steel deionization plates are installed over each contact. **ARS pro** fuse switch disconnectors are designed for using current transformers and ammeters. Protection degree of IP30 from the front is provided. In opened position **ARS pro** provide protection degree IP20. Additionally offered accessories enable to install **ARS pro** fuse switch disconnectors of different sizes on common busbar systems and facilitate operation. All sizes of **ARS pro** fuse switch disconnectors are provided complete with clamps (i. e. screws, V-terminals, 2V-terminals) and shrouds for cable terminals.

Table 27. Technical data ARS pro

Parameter		ARS 00/60 mm pro	ARS 00/100 mm pro	ARS 630 kVA pro	RWS 600 pro	RWS 750 pro	RWS 1250 pro	ARS 1250 pro
Rated thermal current $I_{th}=I_n$ with fuse links	A	160	160	910	-	-	-	1250
Rated thermal current I_{th} with solid links	A	-	-	-	600	750	1250	-
Rated voltage U_n	V	690	690	400	690	500	400	400
Utilization category	690 V	AC-22B	AC-22B	-	AC-22B	-	-	-
	500 V	-	-	-		-	-	-
	400 V	AC-23B	AC-23B	AC-22B		AC-22B	AC-22B	AC-21B
Rated switching current I_e	A	160	160	910	600	750	1250	1250
Rated short-circuit making current	690 V	kA	80	25	-	-	-	-
	500 V		120		-			-
	400 V		-		50			100
Rated short-circuit withstand current	690 V	kA	80	100	-	-	-	-
	500 V		120		-			-
	400 V		-		50			100
Rated insulation voltage U_i	V	1000	1000	1000	1000	1000	1000	1000
Rated impulse withstand voltage $U_{imp.}$	kV	8	8	12	12	12	12	12
Rated short time withstand current I_{cw}	kA	-	-	-	15 ³⁾	15 ³⁾	15/20 ²⁾	-
Rated frequency	Hz	50-60	50-60	50-60	50-60	50-60	50-60	50-60
Mechanical durability	Number of cycles	1600	1600	600	1000	1000	600	600
Electrical durability		200	200	100	200	200	100	100
IP degree of protection	IP	30	30	30	30	30	30	30
Fuse links size	-	00	00	gTr 630 kVA ¹⁾	earthing switches ZN2	earthing switches ZN3	earthing switches ZN3 -1250 A	3

¹⁾ fuse link gTr 630 kVA, DIN 43620, VDE 0636/2011, size NH3

²⁾ with mechanical lock

³⁾ it is recommended to use a mechanical lock

OPERATING CONDITIONS

- to be installed in the room free of any dust, aggressive or explosive gases,
- altitude up to 2000 meters above sea level,
- outdoor – in cabinets with protection degree > IP34,
- ambient temperature from -25°C to +55°C,
- relative humidity of the air should not be higher than 50% at temperature of +40°C.

FUNCTIONALITY

- making and breaking operations should be done with determined movement,
- parallelly moving, double contact system,
- designed for installation on to 60 mm, 100 mm or 185 mm busbar system,
- two versions: single pole switching (separately each pole) or triple pole switching (three poles at the same time),
- width 50 mm (ARS 00/60 mm pro, ARS 00/100 mm pro); width 100 mm (RWS 600 pro, RWS 750 pro, RWS 1250 pro) or 200 mm (ARS 1250 pro),
- suitable for top cable terminal connection,
- possible connection of conductors with lug terminals (screw terminals) or circular/sector-shaped conductors with bare ends (V-terminals, 2V-terminals) using V-clamps,
- voltage test is performed through test holes leading to blade contacts,
- possible installation of various types of earthing devices.

FUSE SWITCH DISCONNECTOR ARS 00/60 mm pro (160 A, 690 V)

Table 28. Technical data

Parameter	ARS 00/60 mm pro		
Rated thermal current $I_{th}=I_n$	A	160	
Rated voltage U_n	V	690	
Utilization category	-	AC-22B	AC-23B
Rated switching voltage U_e	V	690	400
Rated switching current I_e	A	160	
Rated short circuit making current	690 V	kA	80
	500 V		120
Rated short circuit withstand current	690 V	kA	80
	500 V		120
Rated insulation voltage U_i	V	1000	
Rated impulse withstand voltage U_{imp}	kV	8	
Rated frequency	Hz	50-60	
Mechanical durability	Number of cycles	1600	
Electrical durability	Number of cycles	200	
IP degree of protection	IP	30	
Fuse links size	-	00	



ARS 00/60 mm pro

Table 29. Versions

Version of ARS 00/60 mm pro	Article No.
three pole switching - all phases simultaneously (for installation on to 60 mm busbar system)	
ARS 00/60 mm pro cable terminals: bridge terminals with bridge clamps (S) 4-70 mm ² screw terminals with M8 screws	63-002354-001
ARS 00/60 mm-T pro cable terminals: frame clamps 4 - 95 mm ²	63-002354-002

Table 30. ARS 00/60 mm pro terminal clamps

Description	ARS 00/60 mm pro		
Clamp	S-bridge clamp 2 x M5 x 20	screw M8*	double frame clamp
Picture of clamp			
Drawing of clamp			
Cross – section of conductors	4 - 70 mm ²	Conductor with lug termina max 95 mm ²	4 ÷ 95 mm ²
Tightening torque	3 Nm**	10 Nm**	5 Nm**

For stranded conductors using cable ferrules is recommended

*) bars of maximum width of 20 mm and maximum thickness of 5 mm can be fixed to M type screw terminals

**) using tension wrench is recommended

FUSE SWITCH DISCONNECTOR ARS 00/100 mm pro (160 A, 690 V)

For installation on to 100 mm busbar system

Fuse switch disconnecter's width 50 mm

Three pole switching - all phases simultaneously

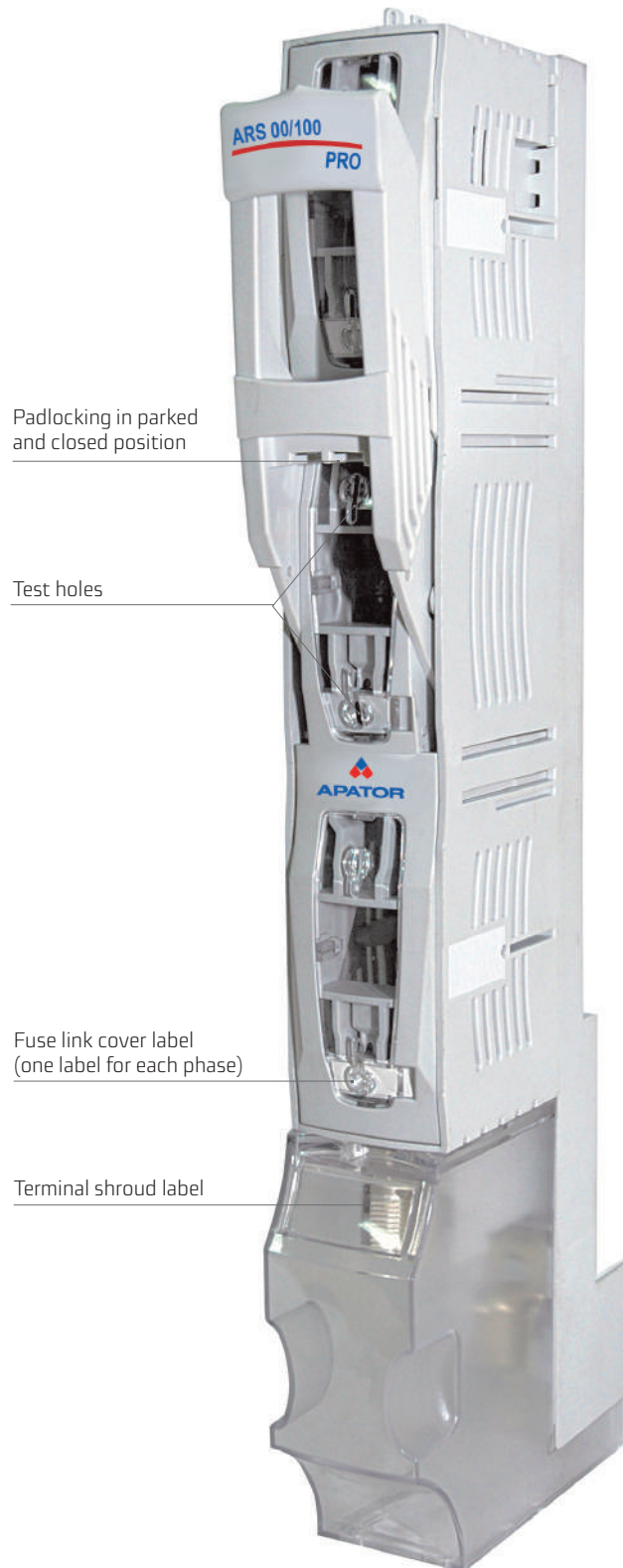

ARS 00/100 mm pro (160 A, 690 V)

Table 31. Technical data

Parameter	ARS 00/100 mm pro	
Rated thermal current $I_{th}=I_n$	A	160
Rated voltage U_n	V	690
Utilization category	-	AC-22B AC-23B
Rated switching voltage U_e	V	690 400
Rated switching current I_e	A	160
Rated short circuit making current	kA	25
Rated short circuit withstand current	kA	100
Rated insulation voltage U_i	V	1000
Rated impulse withstand voltage U_{imp}	kV	8
Rated frequency	Hz	50-60
Mechanical durability	Number of cycles	1600
Electrical durability	Number of cycles	200
IP degree of protection	-	30
Fuse links size	-	00

Accessories on page 55, 56



ARS 00/100 mm pro

Table 32. Versions

Version		Weight	Article No.
three pole switching - all phases simultaneously (for installation on to 100 mm busbar system)			
ARS 00/100 mm pro	cable terminals: bridge terminals with bridge clamps (S) 4-70 mm ² , screw terminals with M8 screws	1,3 kg	63-811628-041
ARS 00/100 mm-V pro	cable terminals: V-terminals with V-clamps 25-150 SW	1,5 kg	63-811628-061

Table 33. ARS 00/100 mm pro terminal clamps

Description	ARS 00/100 mm pro			
	S-bridge clamp 2 x M5 x 20	screw M8*	V-clamp 25-150 SW B	HM 10-120
Picture of clamp				
Drawing of clamp				
Cross-section of conductors	4-70 mm ²	Conductor with lug terminal max 185 mm ²	re ● 16 mm ² - 95 mm ²	re ● 10 mm ² - 70 mm ²
			se ◆ 25 mm ² - 150 mm ²	se ◆ 20 mm ² - 120 mm ²
Tightening torque	3 Nm**	12 Nm**	rm ⊗ 16 mm ² - 95 mm ²	rm ⊗ 10 mm ² - 70 mm ²
			sm ⊗ 25 mm ² - 120 mm ²	sm ⊗ 25 mm ² - 95 mm ²

For stranded conductors using cable ferrules is recommended

*) bars of maximum width of 20 mm and maximum thickness of 5 mm can be fixed to M type screw terminals

**) using tension wrench is recommended

***) fuse switch disconnectors with V-terminals are equipped with steel V-clamp HM 10-120 on request

Apator takes responsibility for technical quality of V-terminals manufactured only by the company. Minimum tightening torque (M8 screw) for screws fixing fuse switch disconnector to busbar system – 12 Nm, recommended tightening torque for screws and nuts with property class 8.8 – 21 Nm.

FUSE SWITCH DISCONNECTOR ARS 630 kVA pro

Fuse switch disconnecter ARS 630 kVA pro is dedicated for protection of transformers up to 630 kVA. Fuse switch disconnecter is designed for operation with NH fuse links of size 3, with gTr characteristic.

Table 34. Technical data

Parameter	ARS 630 kVA pro	
Rated thermal current $I_{th}=I_n$	A	910
Rated voltage U_n	V	400
Utilization category	-	AC-22B
Rated switching voltage U_e	V	400
Rated switching current I_e	A	910
Rated short circuit making current	kA	50
Rated short circuit withstand current	kA	50
Rated insulation voltage U_i	V	1000
Rated impulse withstand voltage $U_{imp.}$	kV	12
Rated frequency	Hz	50-60
Mechanical durability	Number of cycles	600
Electrical durability		100
IP degree of protection	-	30
Weight	kg	8,7
Fuse links size	-	gTr 630 kVA ¹⁾

Accessories on page 57, 58

¹⁾ Fuse link gTr 630 kVA, DIN 43620, VDE 0636/2011, size NH3

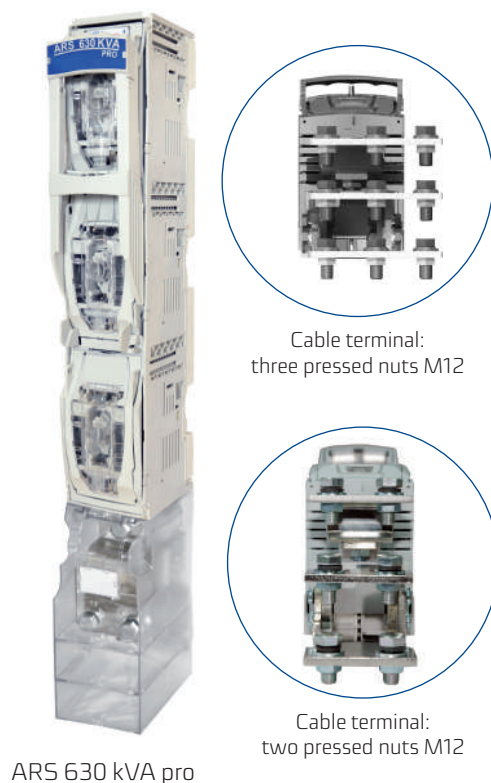

ARS 630 kVA pro

Table 35. Versions

Versions	Article No.
for installation on 185 mm busbar system	
one pole switching - each phase independently	
ARS 630 kVA-1-2M pro cable terminals: screw terminals with two pressed nuts M12/pole, width 100 mm	63-811860-001
ARS 630 kVA-1-3M pro cable terminals: screw terminals with three pressed nuts M12/pole, width 200 mm	63-811860-002
three pole switching - all phases simultaneously	
ARS 630 kVA-6-2M pro cable terminals: screw terminals with two pressed nuts M12/pole, width 100 mm	63-811722-011
ARS 630 kVA-6-3M pro cable terminals: screw terminals with three pressed nuts M12/pole, width 200 mm	63-811722-021

Recommended tightening torque (M12 screw) for screws fixing fuse switch disconnecter to busbar system – 56 Nm, screws and nuts property class 8.8.

Table 36. ARS 630 kVA pro terminal clamps

Description	ARS 630 kVA pro
Clamp	pressed nuts M12
Drawing of clamp	
Cross – section of conductors	Cable lugs, max 300 mm ²
Tightening torque	56 Nm

SWITCH DISCONNECTOR ARS 1250 pro

Fuse switch disconnectors width 200 mm

Table 37. Technical data

Parameter		ARS 1250 pro
Rated thermal current $I_{th}=I_n$	A	1250
Rated voltage U_n	V	400
Utilization category	-	AC-21B
Rated switching voltage U_e	V	400
Rated switching current I_e	A	1250
Rated short circuit making current	kA	100
Rated short circuit withstand current	kA	100
Rated insulation voltage U_i	V	1000
Rated impulse withstand voltage U_{imp}	kV	12
Rated frequency	Hz	50-60
Mechanical durability	Number of cycles	600
Electrical durability		100
IP degree of protection	-	30
Fuse links size	-	3

Accessories on page 57, 58



ARS 1250-1-3M pro

ARS 1250-6-3M pro

Table 38. Versions

Version		Weight	Article No.
for installation on to 185 mm busbar system, fuse disconnectors width – 200 mm			
one pole switching - each phase independently			
ARS 1250-1-3M pro	mechanically and electrically coupled two ARS 3 pro fuse switch disconnectors, cable terminals: screw terminals with three pressed screw M12/pole	16,3 kg	63-811757-011
ARS 1250-1-4M pro	mechanically and electrically coupled two ARS 3 pro fuse switch disconnectors, cable terminals: screw terminals with four pressed screw M12/pole	17 kg	63-811757-021
three pole switching - all phases simultaneously			
ARS 1250-6-3M pro	mechanically and electrically coupled two ARS 3 pro fuse switch disconnectors, cable terminals: screw terminals with three pressed screw M12/pole	16,3 kg	63-811756-011
ARS 1250-6-4M pro	mechanically and electrically coupled two ARS 3 pro fuse switch disconnectors, cable terminals: screw terminals with four pressed screw M12/pole	17 kg	63-811756-021

Recommended tightening torque (M12 screw) for screws fixing fuse switch disconnectors to busbar system – 56 Nm, screws and nuts property class 8.8

Table 39. ARS 1250-x-M pro terminal clamps

Description	ARS 1250-x-3M pro	ARS 1250-x-4M pro
Clamp	three pressed nuts M12	four pressed nuts M12
Drawing of clamp		
Cross-section of conductors	Cable lugs, max 300 mm ²	Cable lugs, max 300 mm ²
Tightening torque	56 Nm	56 Nm

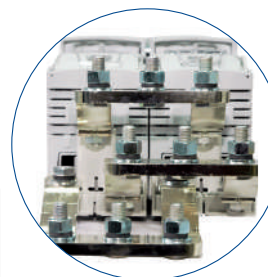

M3 type cable terminals: screw terminals with three pressed screw M12/pole

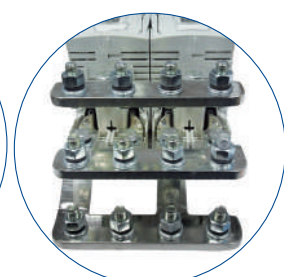

M3 type cable terminals: screw terminals with four pressed screw M12/pole

FUSE SWITCH DISCONNECTOR ARS 400 pro, ARS 600 pro with lateral busbar terminal

(separation, coupling of busbar systems)



ARS 400-6-NR pro

Table 40. Technical data

Parameter		ARS 400 pro	ARS 630 pro
Rated thermal current $I_{th}=I_n$	A	400	630
Rated voltage U_n	V	690	690
Utilization category	-	AC-22B	AC-22B
Rated switching voltage U_e	V	690	690
Rated switching current I_e	A	400	630
Rated short circuit making current	690 V	100	100
	500 V	120	120
Rated short circuit withstand current	690 V	100	100
	500 V	120	120
Rated insulation voltage U_i	V	1000	1000
Rated impulse withstand voltage U_{imp}	kV	12	12
Rated frequency	Hz	50-60	50-60
Mechanical durability	Number of cycles	1000	1000
Electrical durability		200	200
IP degree of protection	-	30	30
Fuse links size	-	1,2	3

Accessories on page 57, 58

Table 41. Versions with lateral busbar terminal

Version		Weight	NrArticle No
for installation on 185 mm busbar system, ONE POLE SWITCHING - each phase independently			
ARS 400-1-NL pro	cable terminals : screw terminals : pressed nuts M12; lateral busbar terminals - left side	5,1 kg	63-811837-011
ARS 630-1-NL pro	cable terminals : screw terminals : pressed nuts M12; lateral busbar terminals - left side	5,1 kg	63-811837-021
ARS 400-1-NR pro	cable terminals : screw terminals : pressed nuts M12; lateral busbar terminals - right side	5,1 kg	63-811837-031
ARS 630-1-NR pro	cable terminals : screw terminals : pressed nuts M12; lateral busbar terminals - right side	5,1 kg	63-811837-041
for installation on 185 mm busbar system, THREE POLE SWITCHING - all phases simultaneously			
ARS 400-6-NL pro	cable terminals : screw terminals : pressed nuts M12; lateral busbar terminals - left side	5,1 kg	63-811838-011
ARS 630-6-NL pro	cable terminals : screw terminals : pressed nuts M12; lateral busbar terminals - left side	5,1 kg	63-811838-021
ARS 400-6-NR pro	cable terminals : screw terminals : pressed nuts M12; lateral busbar terminals - right side	5,1 kg	63-811838-031
ARS 630-6-NR pro	cable terminals : screw terminals : pressed nuts M12; lateral busbar terminals - right side	5,1 kg	63-811838-041

Table 42. ARS 400 pro, ARS 630 pro with lateral busbar terminals terminal clamps

Description	ARS 400-x-NL pro ARS 630-x-NL pro	ARS 400-x-NR pro ARS 630-x-NR pro
Clamp	M12 screw	M12 screw
Drawing of clamp		
Lateral busbar terminal	Left side	Right side
Tightening torque	56 Nm	56 Nm

SWITCH DISCONNECTOR RWS 600 pro (600 A, 690 V)

Switch disconnecter designed for operation with solid links of size 2



RWS 600-6-V pro

Table 43. Technical data

Parameter	RWS 600 pro	
Rated thermal current $I_{th}=I_n$	A	600
Rated voltage U_n	V	690
Utilization category	-	AC-22B
Rated switching voltage U_e	V	690
Rated switching current I_e	A	600
Rated insulation voltage U_i	V	1000
Rated impulse withstand voltage $U_{imp.}$	kV	12
Rated short time withstand current I_{cw}	kA	15 ¹⁾
Rated frequency	Hz	50-60
Mechanical durability	Number of cycles	1000
Electrical durability		200
IP degree of protection	-	30
Solid links size	-	2

[Accessories on page 57, 58](#)

¹⁾ use of mechanical lock recommended

Table 44. Versions

Version	Weight	Article No
for installation on 185 mm busbar system, THREE POLE SWITCHING - all phases simultaneously		
RWS 600-6-V pro cable terminals: V-terminals: V-clamps 240 mm ²	5,8 kg	63-002228-001
RWS 600-6-M pro cable terminals: screw terminals: pressed nuts M12	5,7 kg	63-002228-002
RWS 600-6-2V pro cable terminals: 2V-terminals: double V-clamps 240 mm ²	6,4 kg	63-002228-003

Table 45. RWS 600 pro terminal clamps

Description	RWS 600-6-V pro	RWS 600-6-2V pro	RWS 600-6-2V pro	RWS 600-6-M pro
Clamp	V-clamp 35-300SW-B	V-clamp 2/50-300SW-B	V-clamp HS 2/50-240-C*	M-screw M12**
Drawing of clamp				
Cross – section of conductors	V-clamp for direct fixing of conductor with bare end with cross-section of:			Lug terminal
	35 - 185 mm ² 35 - 240 mm ²	50 - 185 mm ² 50 - 240 mm ²	50 - 185 mm ² 50 - 240 mm ²	
Tightening torque	30 Nm	30 Nm	40 Nm	56 Nm

For stranded conductors using cable ferrules is recommended

*) if the fuse switch disconnecter with a 2V-type clamp is to be equipped with a steel V-clamp HS 2/50-240-C, it should be included in the order

**) bars of maximum width of 40 mm and maximum thickness of 8 mm can be fixed to M type screw terminals when protective barrier between phases is installed Apator takes responsibility for technical quality of V-terminals manufactured only by the company. Minimum tightening torque (M12 screw) for screws fixing fuse switch disconnecter to busbar system – 32 Nm, recommended tightening torque for screws and nuts with property class 8.8 – 56 Nm.

SWITCH DISCONNECTOR RWS 750 pro (750 A, 500 V)

Switch disconnecter designed for operation with solid links of size 3

Table 46. Technical data

Parameter	RWS 750 pro	
Rated thermal current $I_{th}=I_n$	A	750
Rated voltage U_n	V	500
Utilization category	-	AC-22B
Rated switching voltage U_e	V	500
Rated switching current I_e	A	750
Rated insulation voltage U_i	V	1000
Rated impulse withstand voltage U_{imp}	kV	12
Rated short time withstand current I_{cw}	kA	15 ¹⁾
Rated frequency	Hz	50-60
Mechanical durability	Number of cycles	1000
Electrical durability		200
IP degree of protection	-	30
Solid links size	-	3

Accessories on page. 56, 57

¹⁾ use of mechanical lock recommended



RWS 750-6-V pro

Table 47. Versions

Version	Weight	Article No
for installation on 185 mm busbar system, THREE POLE SWITCHING - all phases simultaneously		
RWS 750-6-V pro cable terminals: V-terminals: V-clamps 240 mm ²	6,6 kg	63-002229-001
RWS 750-6-M pro cable terminals: screw terminals: pressed nuts M12	6,5 kg	63-002229-002
RWS 750-6-2V pro cable terminals: 2V-terminals: double V-clamps 240 mm ²	7,2 kg	63-002229-003

Table 48. RWS 750 pro terminal clamps

Description	RWS 750-6-V pro	RWS 750-6-2V pro	RWS 750-6-2V pro	RWS 750-6-M pro
Clamp	V-clamp 35-300SW-B	V-clamp 2/50-300SW-B	V-clamp HS 2/50-240-C*	M-screw M12**
Drawing of clamp				
Cross – section of conductors	V-clamp for direct fixing of conductor with bare end with cross-section of:			
	35 - 185 mm ²	35 - 240 mm ²	50 - 185 mm ²	50 - 240 mm ²
	35 - 240 mm ²	35 - 300 mm ²	50 - 240 mm ²	50 - 300 mm ²
Tightening torque	30 Nm	30 Nm	40 Nm	56 Nm

For stranded conductors using cable ferrules is recommended

^{*)} if the fuse switch disconnecter with a 2V-type clamp is to be equipped with a steel V-clamp HS 2/50-240-C, it should be included in the order

^{**)} bars of maximum width of 40 mm and maximum thickness of 8 mm can be fixed to M type screw terminals when protective barrier between phases is installed Apator takes responsibility for technical quality of V-terminals manufactured only by the company. Minimum tightening torque (M12 screw) for screws fixing fuse switch disconnecter to busbar system – 32 Nm, recommended tightening torque for screws and nuts with property class 8.8 – 56 Nm.

SWITCH DISCONNECTOR RWS 1250 pro

Main switch-disconnector 1250 A, equipped with ZN3 1250A solid-links

Switch-disconnector's width 100 mm

For installation on 185 mm busbar system

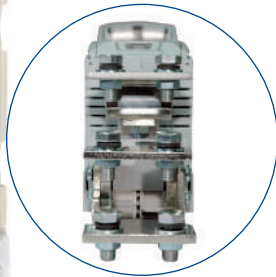

Cable terminal:
two pressed
nuts M12

RWS 1250-6-2M pro

Table 49. Technical data

Parameter		RWS 1250 pro
Rated thermal current $I_{th}=I_n$	A	1250
Rated voltage U_n	V	400
Utilization category	-	AC-22B
Rated switching voltage U_e	V	400
Rated switching current I_e	A	1250
Rated insulation voltage U_i	V	1000
Rated impulse withstand voltage U_{imp}	kV	12
Rated short time withstand current I_{cw}	kA	15/20 ¹⁾
Rated frequency	Hz	50-60
Mechanical durability	Number of cycles	600
Electrical durability		100
IP degree of protection	-	30
Weight	kg	8,7
Solid links size	-	ZN3 -1250 A

[Accessories on page 57,58](#)

¹⁾ with mechanical lock

Table 50. Versions

Version		Article No.
for installation on 185 mm busbar system, THREE POLE SWITCHING - all phases simultaneously		
RWS 1250 - 6 - 2M pro	cable terminals: screw terminals with two pressed nuts M12/pole, width 100 mm	63-811828-011
RWS 1250 - 6 - 3M pro	cable terminals: screw terminals with three pressed nuts M12/pole, width 200 mm	63-811828-021
RWS 1250 - 6 - T pro	power supply connection at the back of the switch disconnector, feeding rail's length = 120 mm, feeding rails designed for fixing with M12 screws	63-811861-001
RWS 1250 - 6 - T pro	power supply connection at the back of the switch disconnector, feeding rail's length = 170 mm, feeding rails designed for fixing with M12 screws	63-811861-002
RWS 1250 NL pro	coupling switch-disconnector with lateral busbar terminals; cable terminals: screw terminals with pressed nuts M12, lateral busbar terminal - left side	63-811862-005
RWS 1250 NR pro	coupling switch-disconnector with lateral busbar terminals; cable terminals: screw terminals with pressed nuts M12, lateral busbar terminal - right side	63-811862-001

Table 51. RWS 1250 pro terminal clamps

Description	RWS 1250 pro
Clamp	pressed nuts M12
Drawing of clamp	
Cross-section of conductors	Cable lugs, max 300 mm ²
Tightening torque	56 Nm



cable terminals:
screw terminals with three
pressed nuts M12/pole

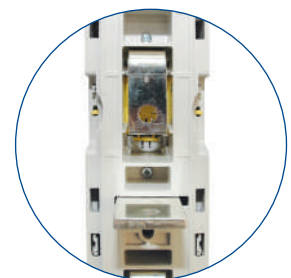

RWS 1250 pro
with outgoing terminals
at the back of the switch

DIMENSIONS

ARS 00-1 evo

CLOSED POSITION

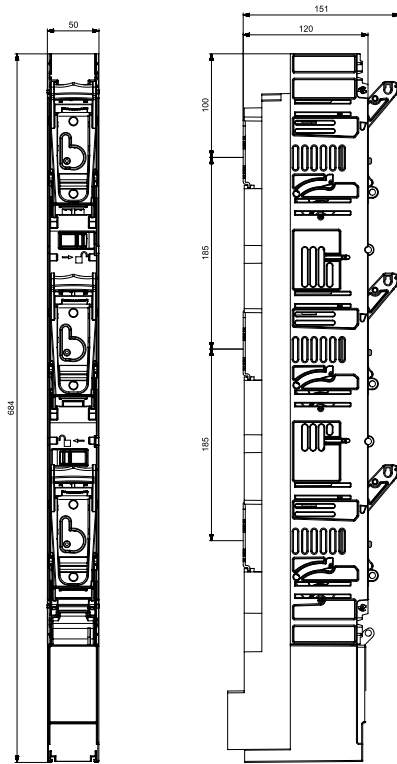

OPEN POSITION

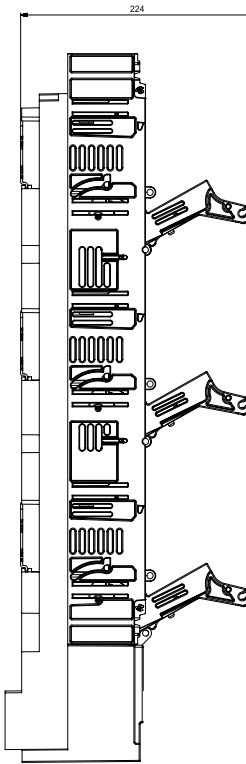

PARKING POSITION

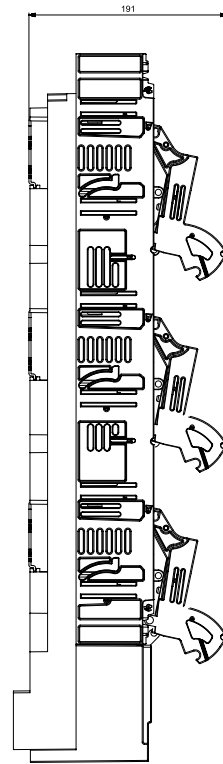

ARS 00-3 evo

CLOSED POSITION

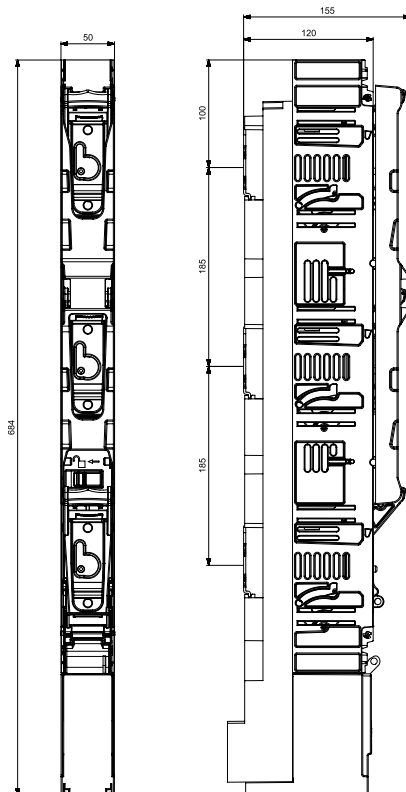

OPEN POSITION

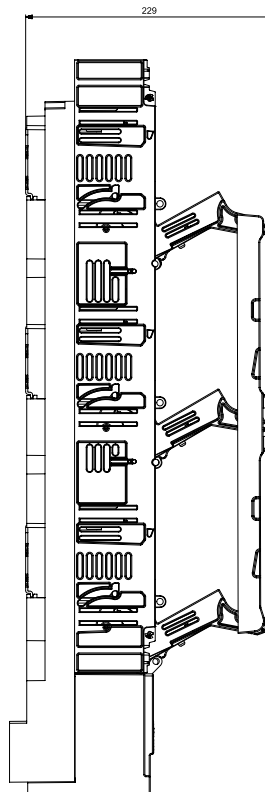

PARKING POSITION

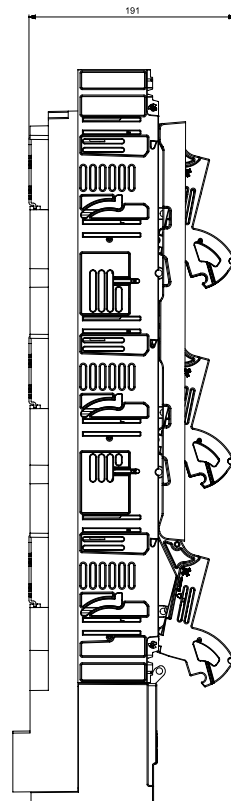

ARS 2-6-M evo, ARS 3-6-M evo

CLOSED POSITION

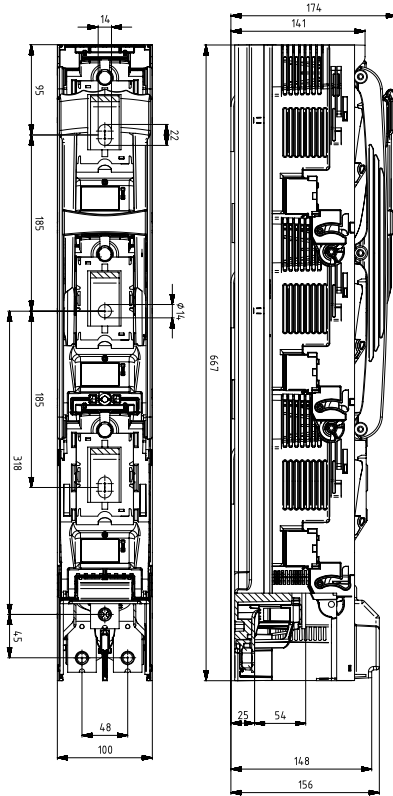

PARKING POSITION

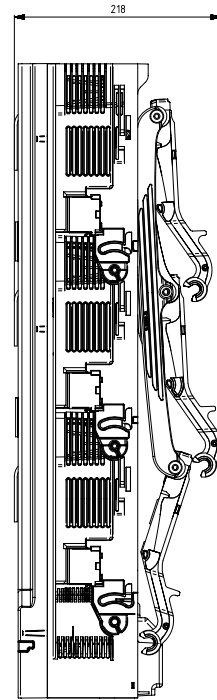

ARS 2-6-V evo, ARS 3-6-V evo

CLOSED POSITION

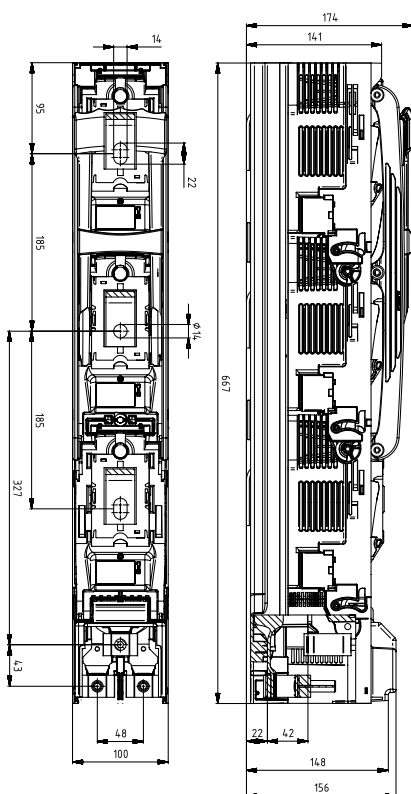

OPEN POSITION

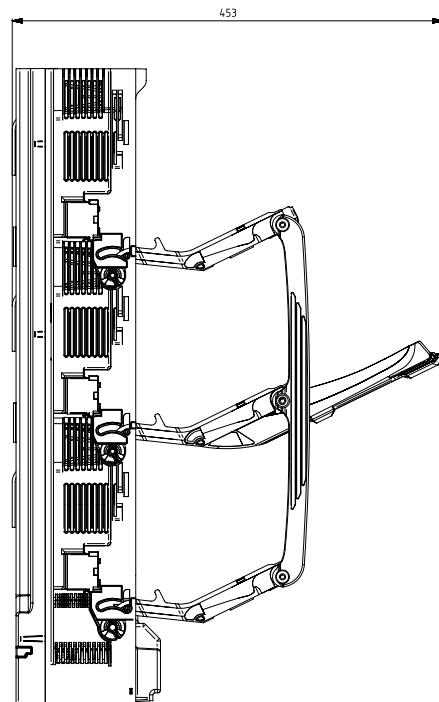

ARS 2-1-2V evo, ARS 3-1-2V evo

ARS 2,3 evo 210

CLOSED POSITION

CLOSED POSITION

WITH RETRACABLE HANDLES

PARKING POSITION

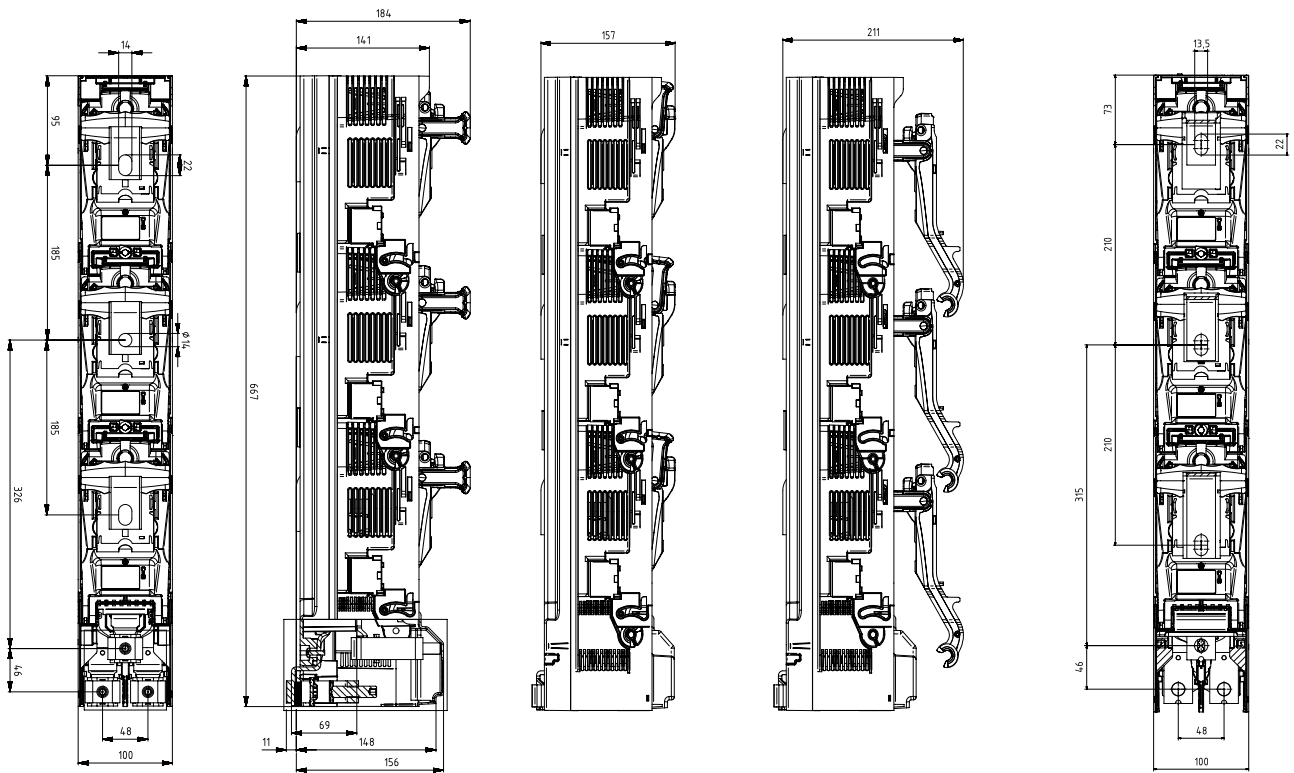

ARS OVERALL DIMENSIONS

smartARS 2 P pro, smartARS 3 P pro
1-phase

3-phase

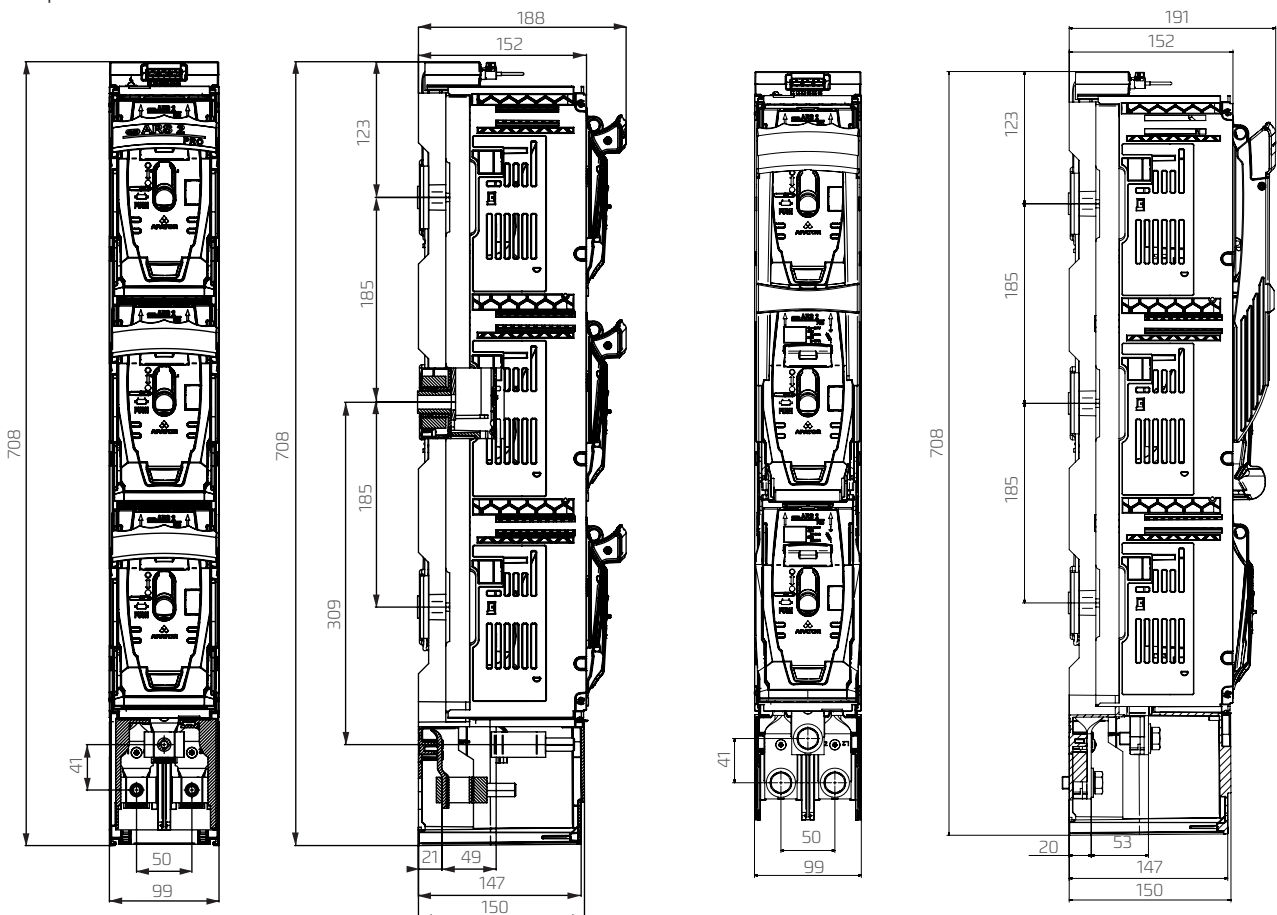

smartARS 00 pro-PV

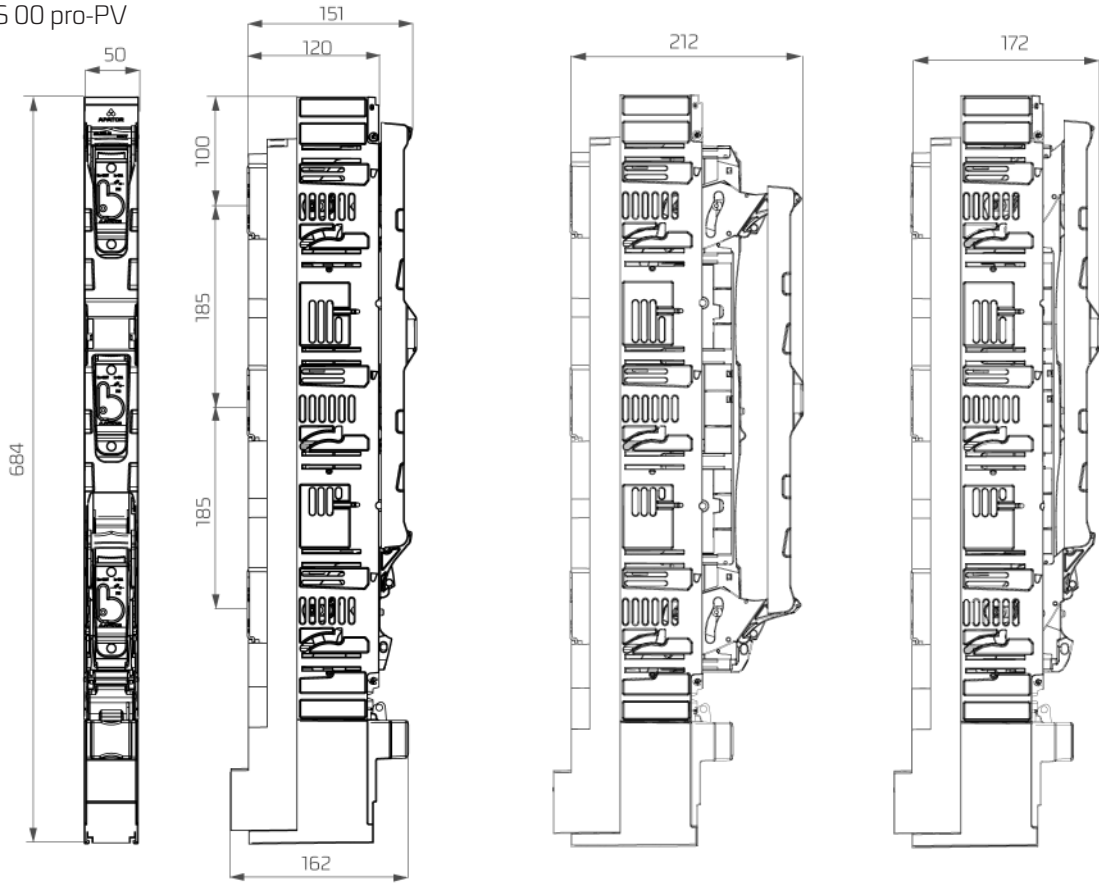

smartARS 2,3 -M,-V pro-PV

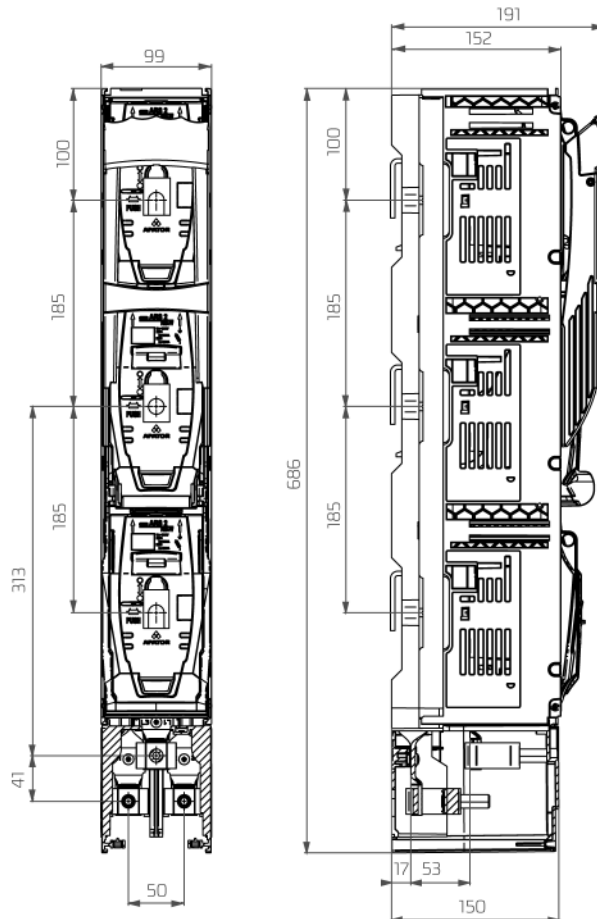

smartARS 2,3 -2V pro-PV

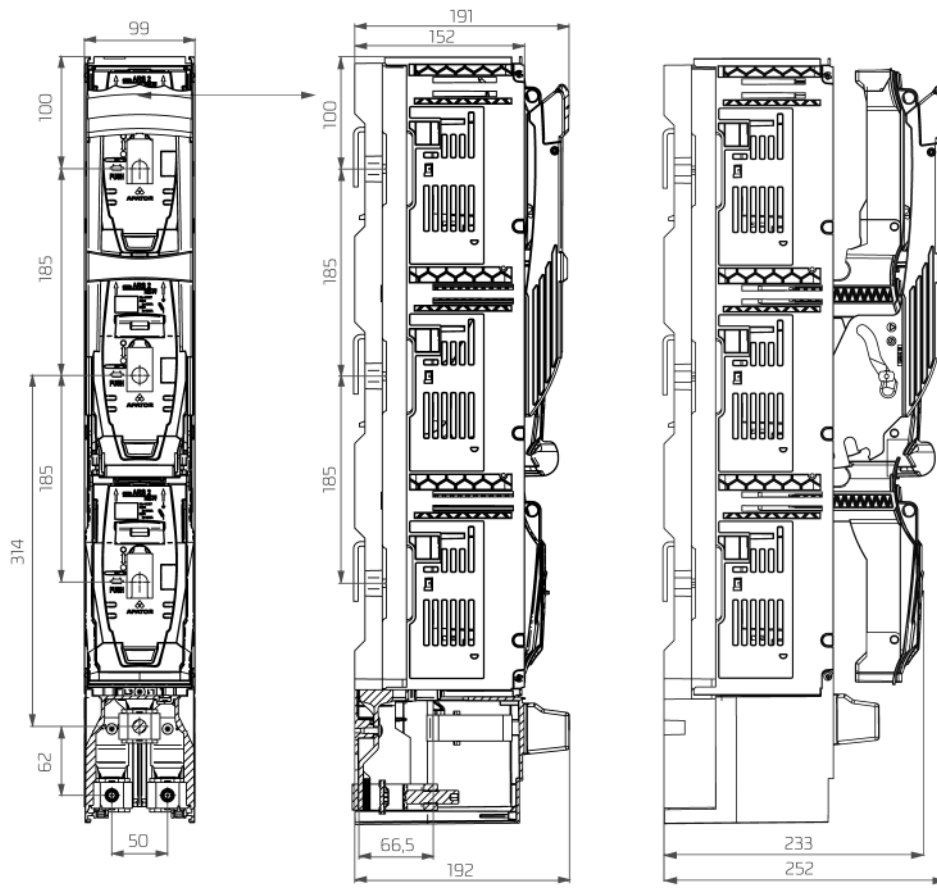

smartARS 00-W-H pro

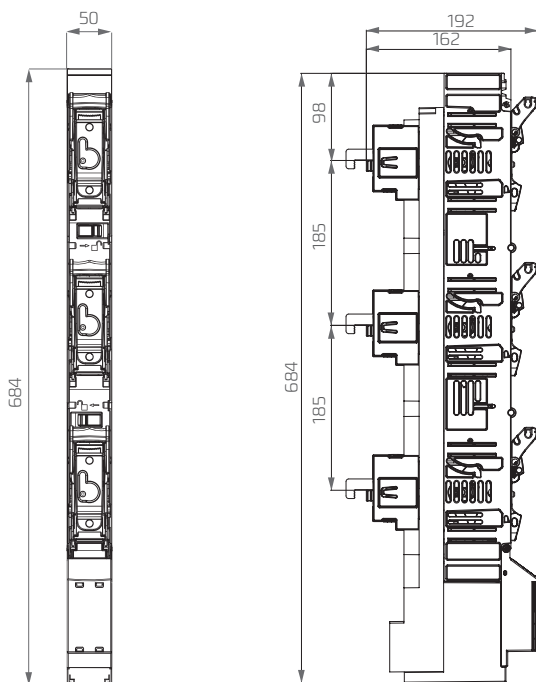

smartARS 2,3-H pro

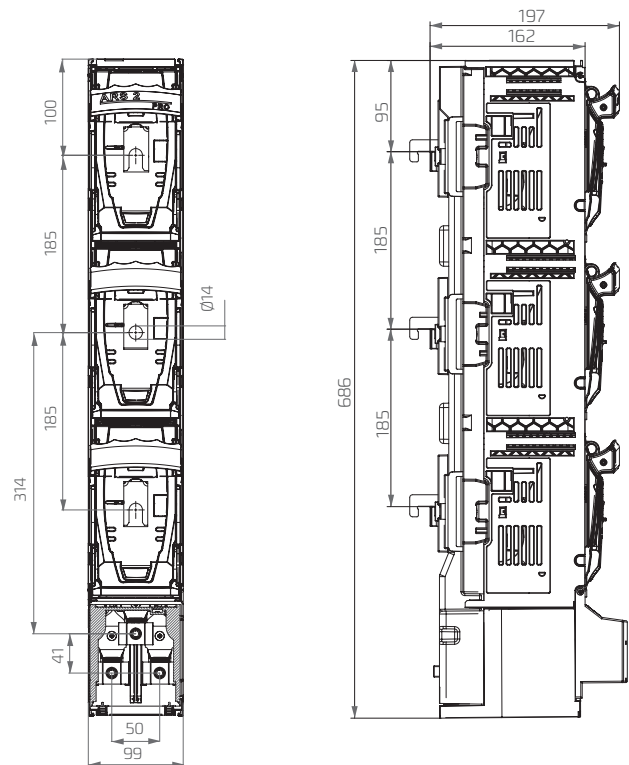

ARS 00/60 mm pro

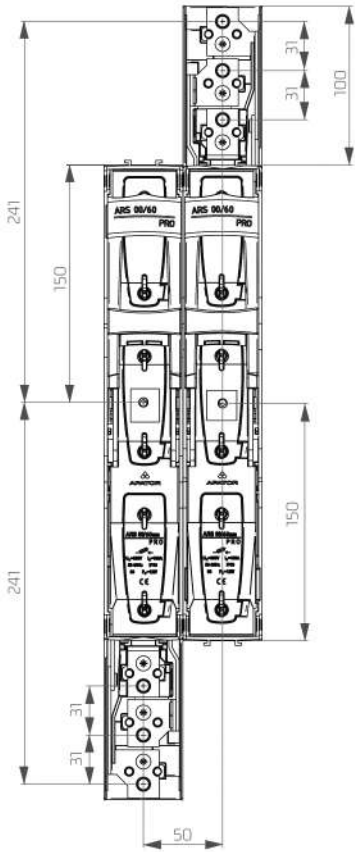

OPEN

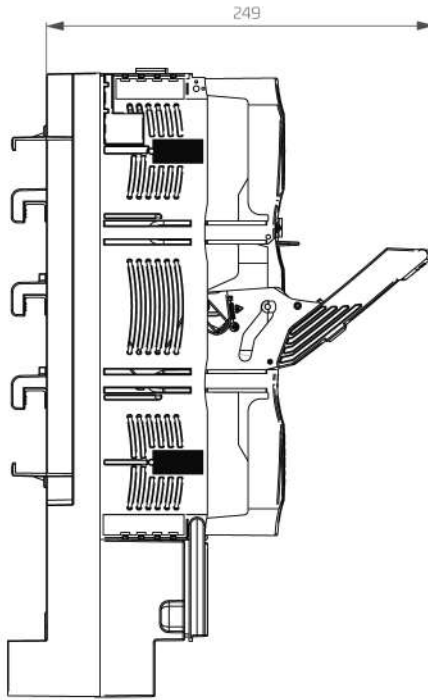

PARKED

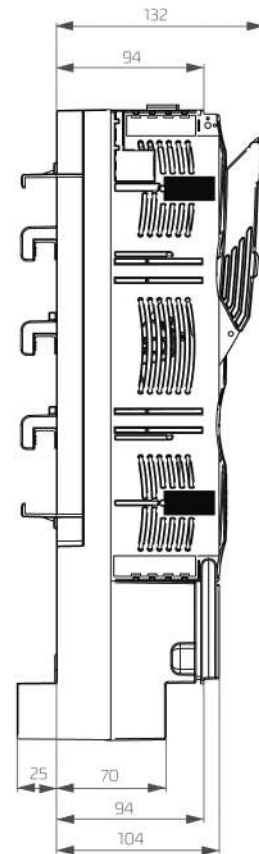
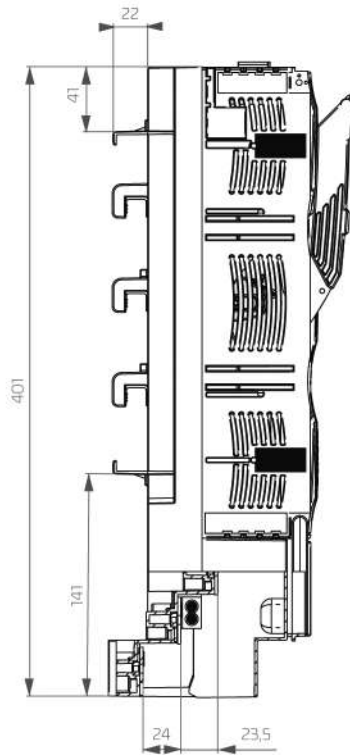
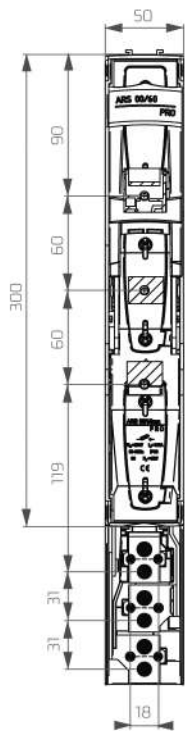
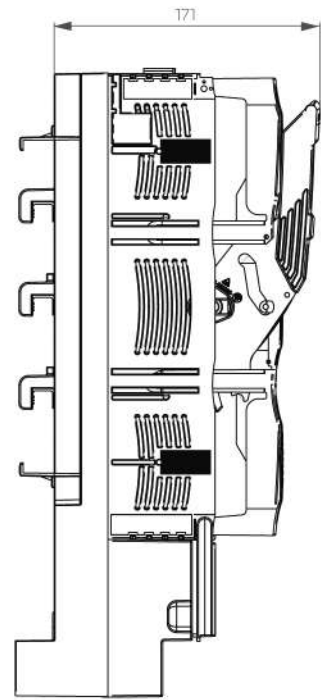

ARS 00/100 mm pro

CLOSED

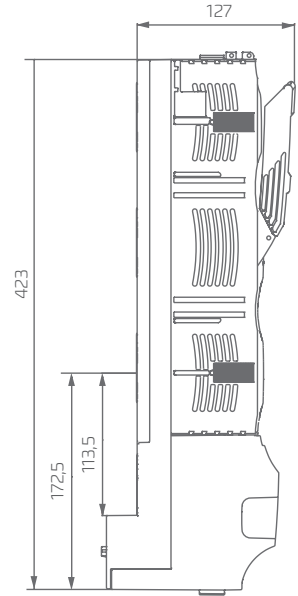
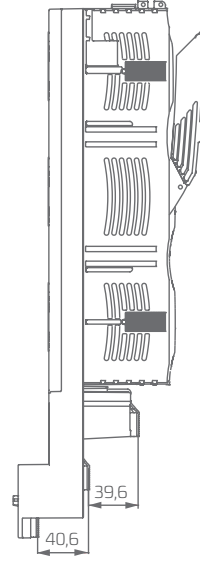
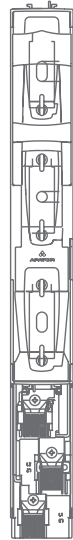
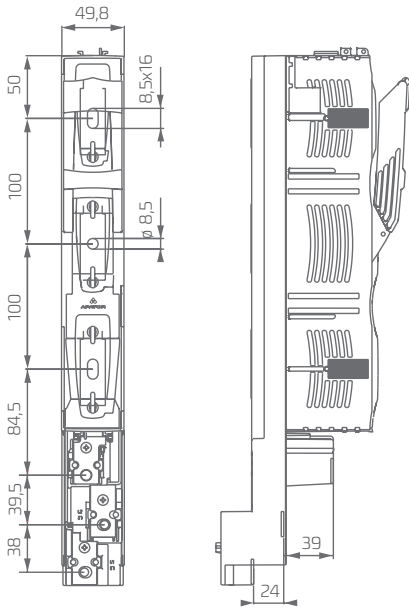

OPEN

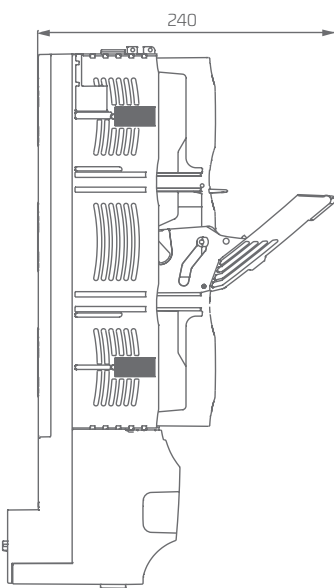

PARKED

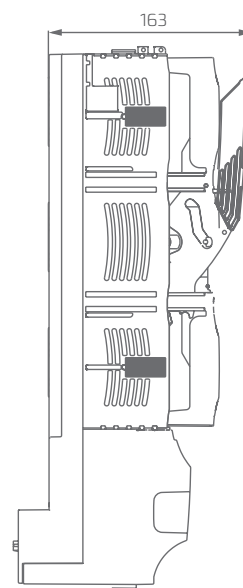

ARS OVERALL DIMENSIONS

Terminals 3x120 mm²

ARS OVERALL DIMENSIONS

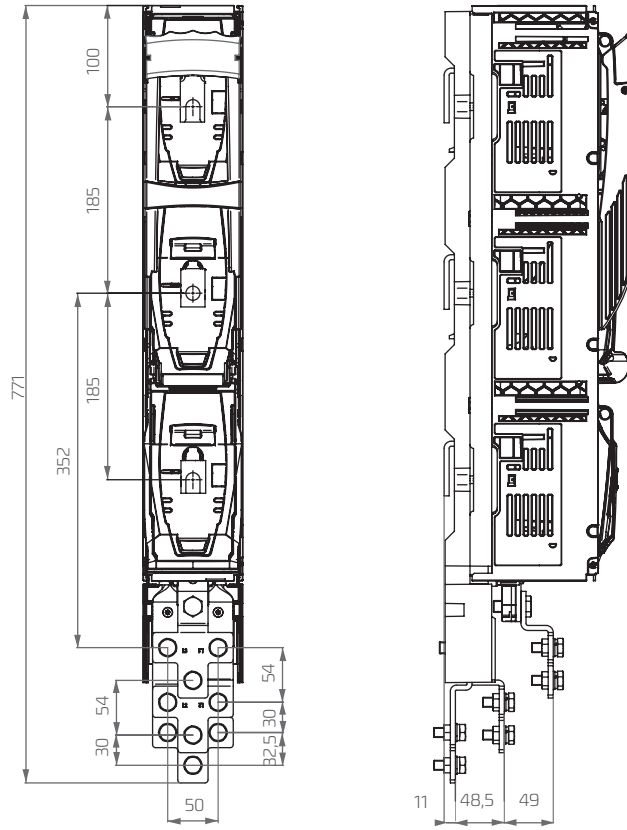

Terminals 2x240 mm²

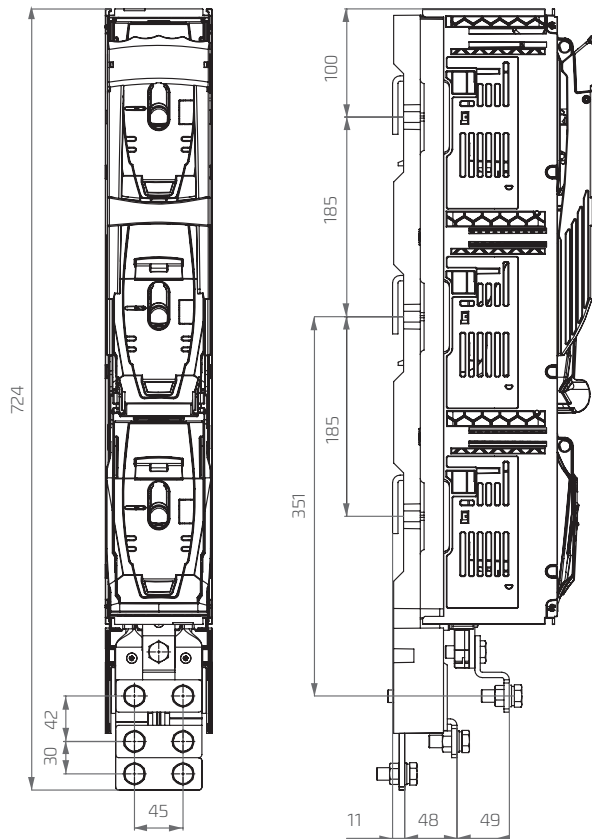

ARS 630 kVA pro
1-phase

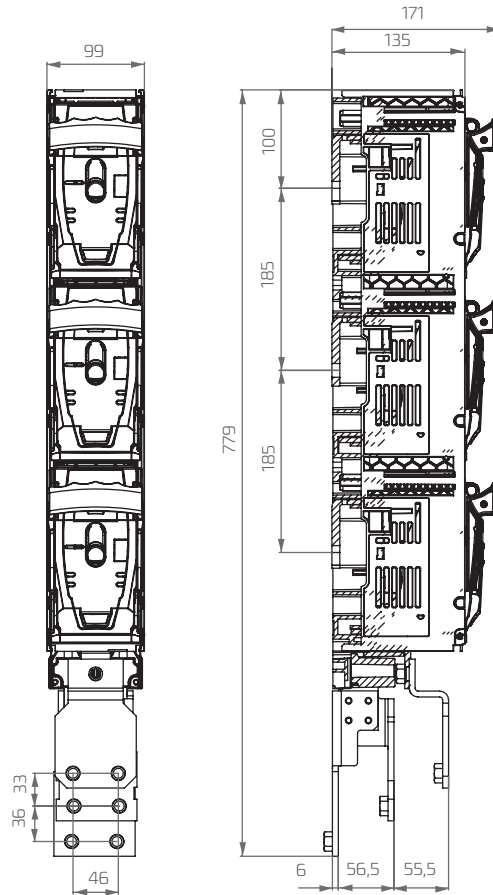

ARS 630 kVA pro, RWS 1250 pro
3-phase

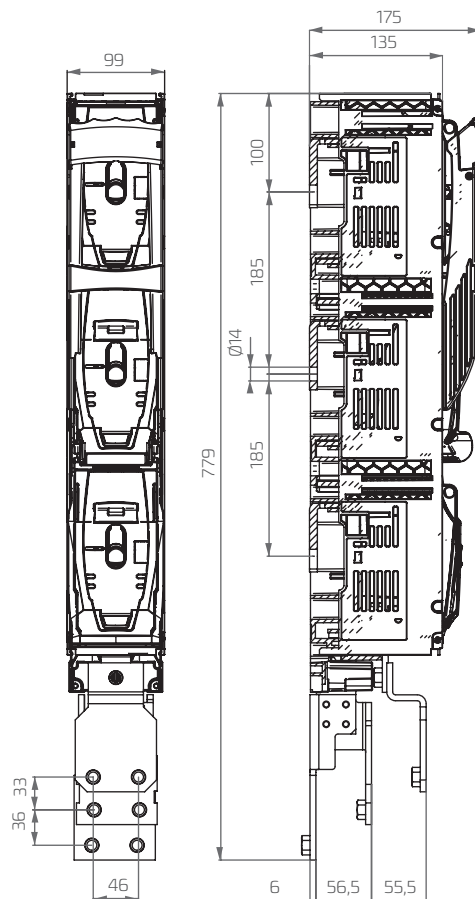

ARS 1250-6-3M pro

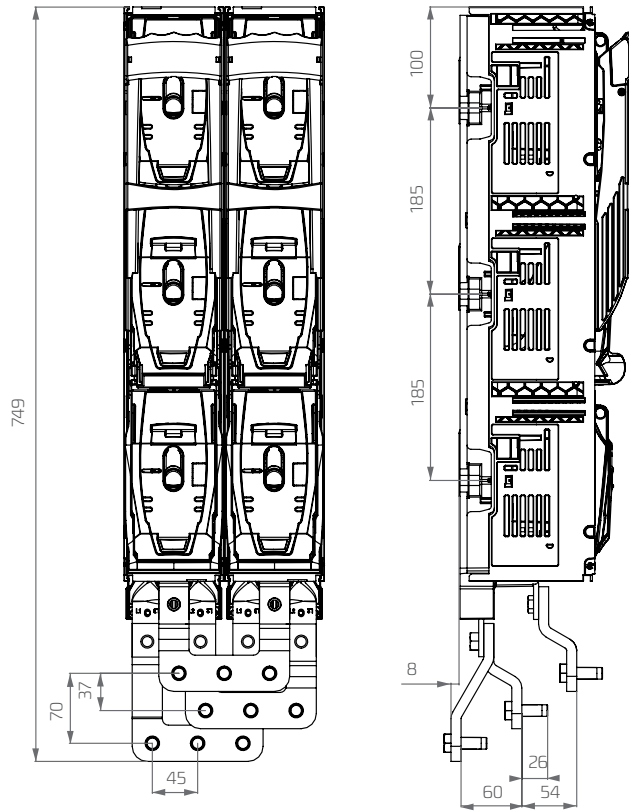

ARS 1250-6-4M pro

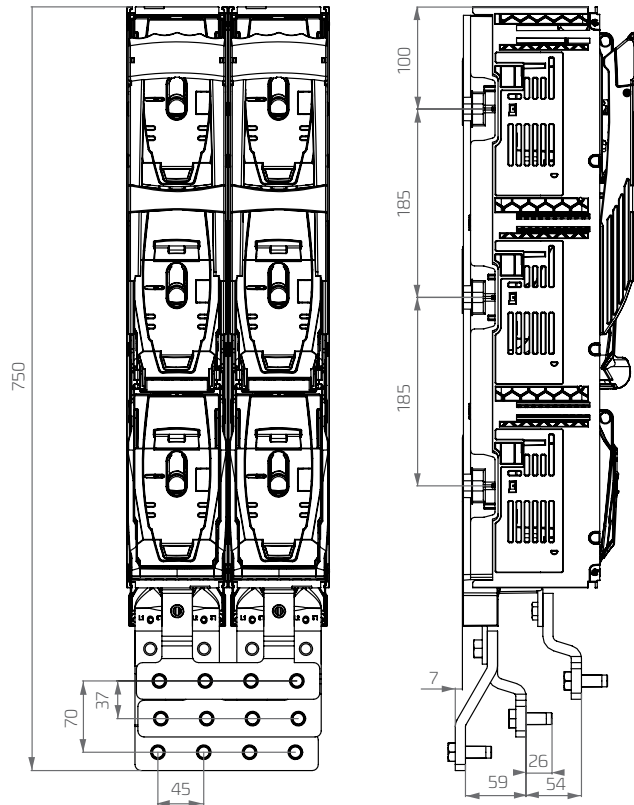

RWS 1250-NT pro

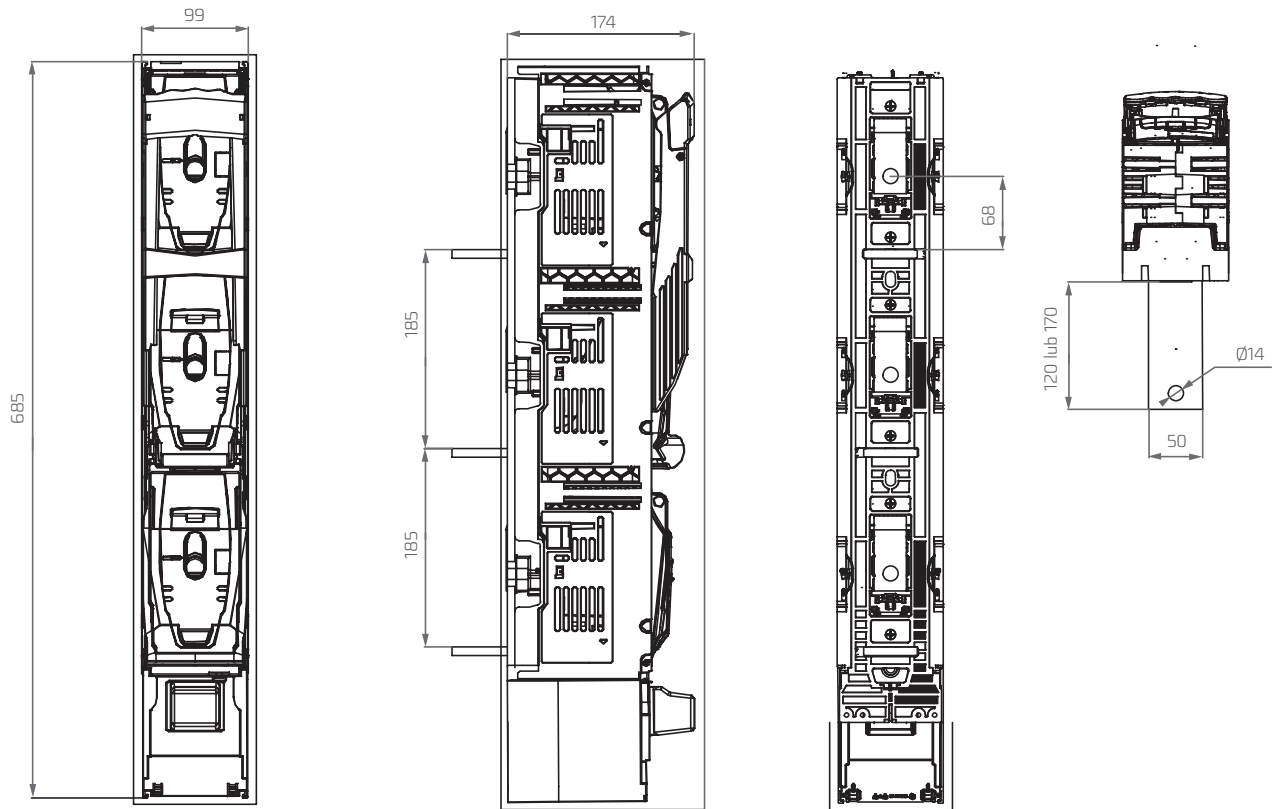

RWS 1250-NL pro

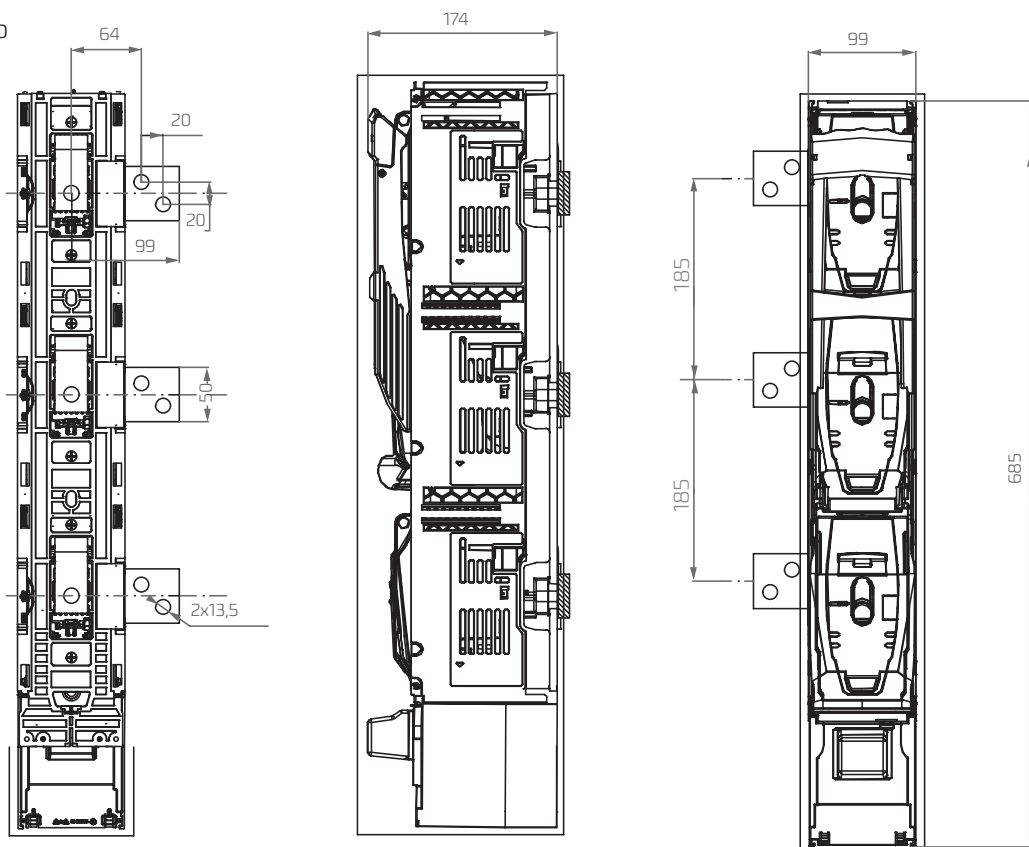

RWS 1250-NR pro

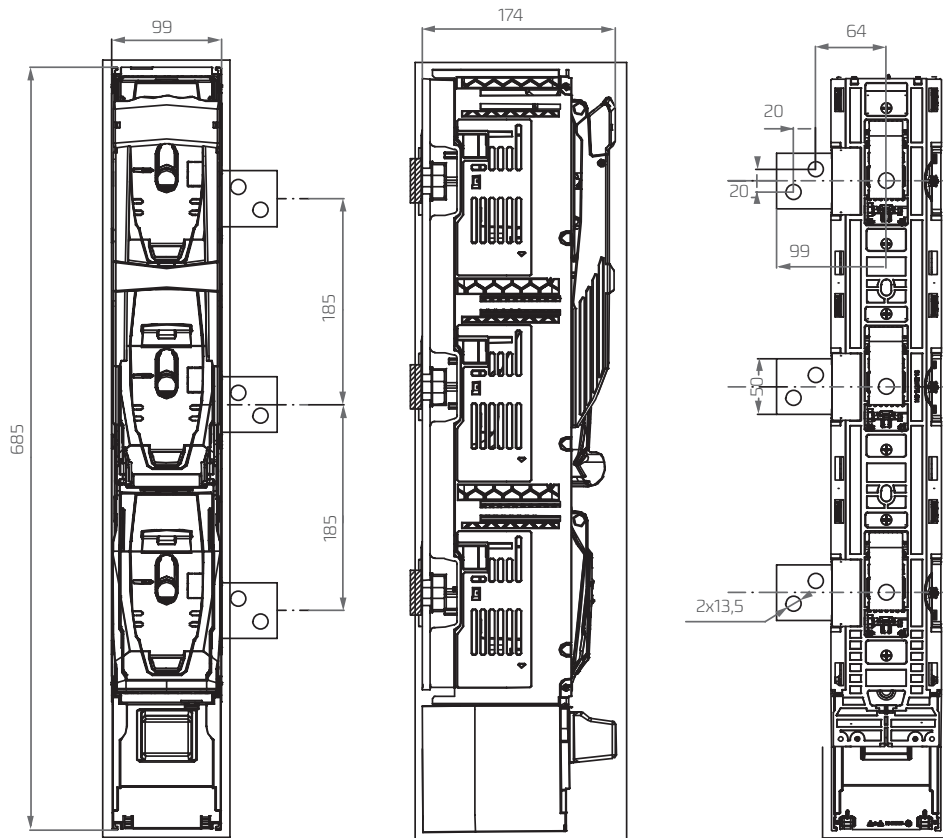

ARS OVERALL DIMENSIONS

Double adapter adjusts the height of smartARS 00 pro to the height smartARS 2,3 pro - article No. 1115281023T

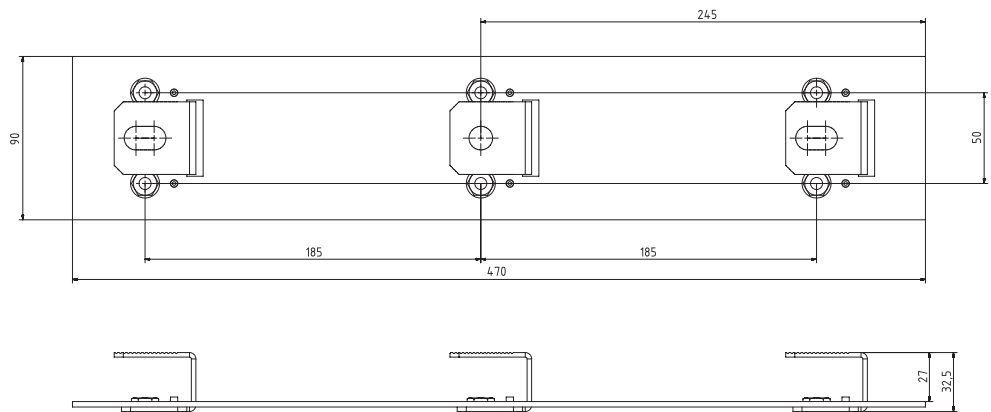

Double adapter adjusts the height of ARS 00 evo to the height ARS 2,3 evo - article No.1115281024T

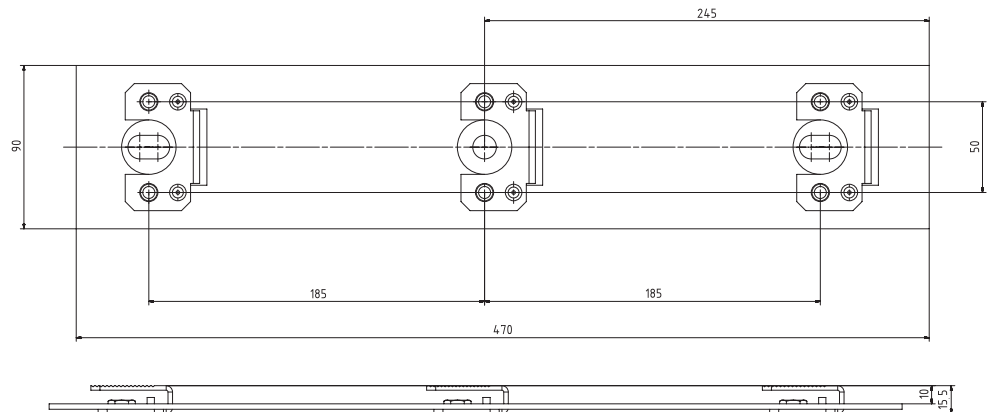

DUAL DRIVE MECHANICAL COUPLING FOR smart ARS pro and ARS pro DISCONNECTORS

Single-phase and three-phase dual drive couplers enable the mechanical connection of two disconnector units installed next to each other. Ready-made dual drive sets allow for quick assembly after removing the elements marked with a red circle on the housings. The components should be removed from the side of the housings that will be connected.

The combined dual drive couplers are labeled, ensuring quick and easy identification of the connected devices.



Tabela 52. Version

Version	Article number
Dual drive 1-f smartARS 2 pro	53-073202-001
Dual drive 1-f smartARS 3 pro	53-073202-002
Dual drive 3-f smartARS 2 pro	53-073201-001
Dual drive 3-f smartARS 3 pro	53-073201-002

Dual drive 1-f *



*set - 3 pcs.

Dual drive 3-f



smartARS 00 pro, ARS 00/100 mm pro, ARS 00 evo - accessories

Description	Article No.	Picture
M8 terminal screw, for connection of conductors with lug terminal (set - 3 pcs.)	53-082961-001	
Busbar shroud (polycarbonate) for busbar system 185 mm, Width 50 mm, length 562 mm, thickness 3 mm	1361400006T	
Isolating pin for fixing the 50 mm busbar shroud, M8 (set – 2 pcs.)	1361400001T	
Distance sleeve for current transformer APA-W10 (Length 36 mm, outer diameter = 22,5 mm, inner diameter =12,5 mm)	1115718010T	
S-bridge clamp – fixed with 2 x M5 screw - for connection of conductors with cross-section 4 mm ² up to 70 mm ² (set – 3 pcs.)	53-002143-001	
V-shape clamp – S-bridge clamp + V-shape saddle - for connection of sector-shaped conductors with cross-section 1,5 up to 70 mm ² (stranded) or 95 mm ² (solid) (set - 3 pcs.)	53-001462-001	
Universal earthing device for ARS 00, 1, 2, 3	1115281041T	
V- clamp 25-120 SW. For connection of conductor with cross-section:	1119510008T	
16 - 95 mm ² 16 - 95 mm ² 25 - 120 mm ² 25 - 120 mm ²		
V- clamp HM-10-120. For connection of conductor with cross-section:	1119510077T	
10 - 70 mm ² 10 - 70 mm ² 25 - 120 mm ² 25 - 95 mm ²		
Hooked clamps for installation of ARS on to busbar system without drilled holes. (set - 3 pcs.) Tightening torque 8 Nm	53-001462-003	











smartARS 00-1 pro ARS 00/100 mm pro

ARS 00/100 mm pro - accessories

Description	Article No.	Picture
Micro switch for fuse link cover position monitoring (0-1) of ARS 00/100 mm	1115296049	
Support angle for installation of busbar shroud	1115281081T	



ARS 00/100 mm pro

Description	Article No.	Picture
Labelling area	53-945333-011	
Terminal shroud/adjusting shroud	53-945924-011	
Flat terminal shroud	51-011242-001	
Flat terminal shroud in RAL 7035 (grey)	51-0011242-002	
Extended terminal shroud. Together with two flat terminal shrouds 51-011242-001 it adjusts the length of smartARS 2,3 pro, ARS 400,	51-823245-001	
Extended terminal shroud in RAL 7035 (grey). Together with two flat terminal shrouds 51-011242-002 it adjusts the length of smartARS 2,3 pro, ARS 400, ARS 400 pro, ARS 630 and ARS 630 pro	51-823245-002	
Single adapter 100/185 enabling to install ARS 00/100 mm on busbar system 185 mm	1115281021T	
Double adapter 100/185 enabling to install two ARS 00/100 mm units on busbar system 185 mm at perforation holes in busbar system every 100 mm	1115281022T	

smartARS 00 pro, ARS 00 evo - accessories

Description	Article No.	Picture
Double adapter adjusts the height of smartARS 00 pro to the height smartARS 2,3 pro	1115281023T	
Double adapter adjusts the height of smartARS 00 pro to the height ARS 2,3 evo	1115281024T	
Single distance adapter 185/185 for ARS 00 or smartARS 00 pro adjusts the front line to ARS 2,3 evo (set – 3 pcs.)	51-005241-001 (no. regard 1 pc.)	
Single distance adapter 185/185 for ARS 00 or smartARS 00 pro adjusts the front line to smartARS 2,3 pro (set – 3 pcs.)	51-005242-001 (no. regard 1 pc.)	
Double distance adapter 185/185 for two units ARS 00 or smartARS 00 pro adjusts the front line to ARS 2,3 evo at perforation holes in busbar system every 100 mm (set – 3 pcs.)	52-005262-001 (no. regard 1 pc.)	
Double distance adapter 185/185 for two units ARS 00 or smartARS 00 pro adjusts the front line to smartARS 2,3 pro at perforation holes in busbar system every 100 mm (set – 3 pcs.)	52-005263-001 (no. regard 1 pc.)	
Hooked clamps (set-3 pcs.) for smartARS 00 pro with heighthened rails adjusted to front line of smart ARS 2,3 pro	53-945361-041	



smartARS 00-1 pro

Description	Article No.	Picture
M10 terminal screw, for connection of conductors with lug terminal (set - 3 pcs.)	53-082961-002	
M12 terminal screw, for connection of conductors with lug terminal (set - 3 pcs.)	53-082961-003	
V-clamp with tightening torque 30 Nm for connection of conductor with cross-section:	1119510081T	
35 - 120 mm ² 35 - 150 mm ²		
35 - 240 mm ² 35 - 300 mm ²		
V-clamp with tightening torque 40 Nm for connection of conductor with cross-section:	1119510084T	
35 - 185 mm ² 35 - 240 mm ²		
35 - 240 mm ² 35 - 300 mm ²		
Double V-clamp with tightening torque 30 Nm for connection of two conductors with cross-section:	1119510082T	
50 - 185 mm ² 50 - 240 mm ²		
50 - 240 mm ² 50 - 300 mm ²		
Double V-clamp with tightening torque 30 Nm for connection of two conductors with cross-section:	1119510085T	
50-185 mm ² 50-240 mm ²		
50-240 mm ² 50-300 mm ²		
Cable terminal 2x240 mm ² Cable terminal for connection of two cables with lug terminals and cross-section of 240 mm ² to each phase Set contains two M12 screws per terminal and cable terminal shroud. For use with smartARS 2,3 pro, ARS 2,3 evo with M terminals	1119510126T	
Cable terminal 3x120 mm ² Cable terminal for connection of three cables with lug terminals and cross-section of 120 mm ² to each phase Set contains three M12 screws per terminal and cable terminal shroud. For use with ARS 2 pro, ARS 3 pro, ARS 400 with M terminals	53-931201-001	
Hooked clamps for installation of ARS 1, 2, 3 on to busbar system without drilled holes (set-3 pcs.) Tightening torque 25 Nm.	53-001462-002	
Cable terminal 1x500mm ² /2x240mm ² . Cable terminal for connection of two cables with lug terminals and cross-section of 240 mm ² to each phase or the connection of a single 500mm ² cable terminated with a cable lug. Set contains three M12 screws per terminal and cable terminal shroud and three M16 screws with disc washers and a connection terminal cover.	1119510121T	
Connection 1x500mm ² - a cable connection allowing a single 500mm ² cable terminated with a cable lug to be connected in phase - set includes three M16 screws with disc washers and a cover for the connection terminals,	1119510122T	



ARS 630-1-M pro



smartARS 2-1-M pro



smartARS 3-1-M pro



ARS 630 kVA pro



ARS 1250-1-3M pro

Opis	Nr katalogowy	Zdjęcie
Busbar shroud (polycarbonate) for busbar system 185 mm, Width 100 mm, length 707 mm, thickness 2 mm	1361400007T	
Isolating pin for fixing the 100 mm busbar shroud, M12 (set – 2 pcs.)	1361400002T	
Distance sleeve for current transformer APA-W12 Length 36 mm, outer diameter =22,5 mm, inner diameter =12,5 mm	1115718010T	
Universal earthing device for: 00, 1, 2, 3	1115281041T	
Rotary cover 2V	51-000487-001	
Insert control module cover	63-002362-002	
Intermediate analyzer module for use in the smartARS X apparatus	63-084301-005	
Intermediate analyzer module with 1 auxiliary contact for use in the smartARS XT pro 3-phase disconnecter apparatus	63-084301-006	
Intermediate analyzer module with 3 auxiliary contacts for use in the smartARS XT pro 1-phase disconnecter apparatus	63-084301-007	
Fuse link status control module (SMW version) for smartARS X pro apparatus	63-000406-003	
Fuse link status monitoring module (SMR version) for smartARS XT pro apparatus	63-000406-008	
Additional cover	51-000331-001	
Miniature switch for controlling the cover position of the disconnecter (0 - 1)	1115296316	



PBS

vertical fuse rails

- self extinguishing thermoplastics with flame retardant
- touch protection IP20 with fuse link shrouds

GENERAL INFORMATION

PBS fuse rails thanks to its high technical standards are among top such products. They are approved and recognized by polish and foreign electricity boards and distribution boards manufacturers.

APPLICATIONS

PBS fuse bases are designed for the distribution of electricity and protection against short circuits and overloads in three phase alternative current circuits with maximum operating voltage of 690 V. They are intended for direct installation on horizontal or vertical bus bar system. Due to their modern and compact design installing is easy and gives much saving of space in substations and distribution boards.

All technical parameters required by standards and requirements of the market were taken into account during design (conformity with EN 60269-1, EN 60269-2, IEC 60269). Several advices and remarks from business partners were also taken into account.

OPERATING CONDITIONS

- to be installed in the room free of any dust, aggressive or explosive gases,
- ambient temperature from -25°C to +55°C – but in case of use of disconnectors in temperature from +41°C to +45°C current value Ith should be reduced by 5% and within temperature range of +46°C to +55°C current value Ith should be reduced by 10%,
- altitude up to 2000 meters above sea level,
- relative humidity of the air should not be higher than 50% at temperature of +40°C,
- outdoor – in cabinets with protection degree > IP34.

CONSTRUCTION

- plastic parts of **PBS** fuse rails are made of fibre glass strengthened, thermoplastic polyamides,
- silver plated contacts provide low power loss,
- all energized metal parts are fully protected against accidental touch.

FUNCTIONALITY

- **PBS** fuse rails are available in following sizes : 00 -160 A; 1-250 A; 2 -400 A; 3-630 A,
- designed for installation on to 185 mm busbar system, (size 00,1,2,3),
- **PBS** 00/100 mm fuse rails are designed for installation on to 100 mm busbar system, installation on to 185 mm busbar system is possible by using adapter,
- fuse rails width: size 00/100, 00-SM - 50 mm, size 1, 2, 3 -100 mm,
- removal of the fuse link provides clearly noticeable, large isolating gap in the circuit,
- possible installation of various earthing devices,
- possible connection of circular or sector-shaped conductors with bare ends (V-terminals, 2V-terminals or conductors with lug terminals (screw terminals),
- touch protection IP20 with fuse link shrouds for fuse rails of size 00, 1, 2 and 3.

Table 53. PBS fuse rails technical data

Parameter		PBS 00/100 mm	PBS 00	PBS 1	PBS 2	PBS 3
Size		00	00	1	2	3
Rated thermal current I_{th}	A	160	160	250	400	630
Rated voltage U_n	V	690	690	690	690	690
Rated insulation voltage U_i	V	1000	1000	1000	1000	1000
Rated frequency	Hz	50-60	50-60	50-60	50-60	50-60
Rated power dissipation	W	12	12	max. 32	45	60
Rated short-circuit withstand current	kA	100	100	100	100	100
Mechanical durability	Number of cycles	100	100	100	100	100
Weight	kg	0,75	2	20	4,50	5
IP degree of protection	-	00	20 ¹⁾	20 ¹⁾	20 ¹⁾	20 ¹⁾
Size of fuse links		00	00	1	1,2	3

¹⁾ with fuse link shrouds

FUSE RAIL PBS 00/100 mm (160 A, 690 V)

For 100 mm busbar system

PBS 00/100 mm

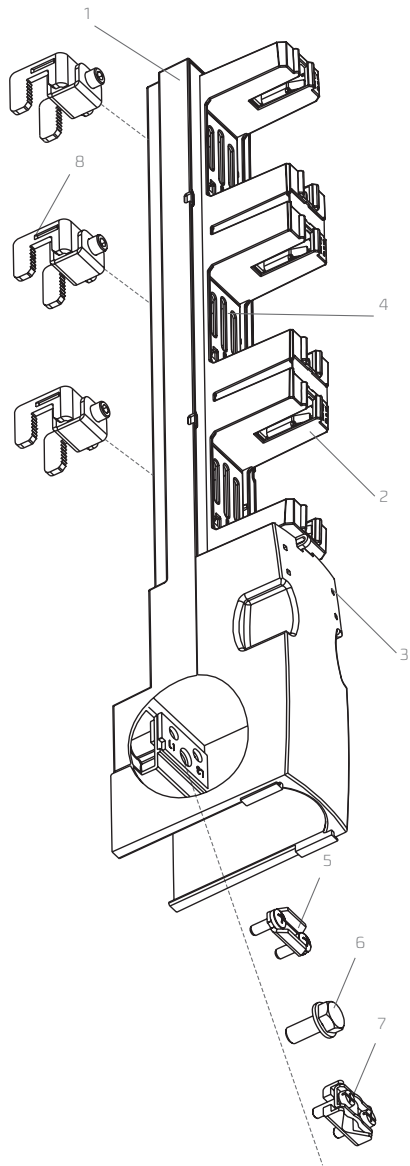

DESCRIPTION

1. Main base
2. Protective contact cover
3. Terminal shroud
4. Busbar terminals acces covers
5. S-bridge clamp
6. M8 screw
7. V-shape clamp for sector-shaped conductor
8. Hooked clamp

Place of installing
insulating barrier

Place of installing clip
with description label

Terminal shroud label



PBS 00/100 mm (160 A, 690 V)



PBS 00/100 mm

Table 54. Technical data

Parameter		PBS 00/100 mm
Size		00
Rated thermal current I_{th}	A	160
Rated voltage U_n	V	690
Rated insulation voltage U_i	V	1000
Rated frequency	Hz	50-60
Rated power dissipation	W	12
Rated short-circuit withstand current	kA	100
Mechanical durability	Number of cycles	100
IP degree of protection	-	00
Size of fuse links		00

Accessories on page 70

Table 55. Versions

Version		Weight	Article No.
PBS 00/100 mm	cable terminals: bridge terminals with bridgeclamps (S) 4-70 mm ² , screw terminals with M8 screws	1,0 kg	63-811627-011
PBS 00/100 mm/A2	cable terminals: bridge terminals with bridgeclamps (S) 4-70 mm ² , screw terminals with M8 screws*	1,0 kg	63-046100-001
PBS 00/100 mm-V	cable terminals: V-terminals with V-clamps 25-150SW	1,1 kg	63-811627-021

* Stainless steel normals

Table 56. PBS 00/100 mm terminal clamps

Description	PBS 00/100 mm			
Clamp	S-bridge clamp 2 x M5 x 25	M8 screw*	V-clamp 25-150 SW B	HM 10-120
Picture of clamp				
Drawing of clamp				
Cross-section of conductors	4-70 mm ²	Conductor with lug terminal max 185 mm ²	re ● 16 mm ² -95 mm ² se ◆ 25 mm ² -150 mm ² rm ⊗ 16 mm ² -95 mm ² sm ⊕ 25 mm ² -120 mm ²	re ● 10 mm ² -70 mm ² se ◆ 25 mm ² -120 mm ² rm ⊗ 10 mm ² -70 mm ² sm ⊕ 25 mm ² -95 mm ²
Tightening torque	3 Nm**	12 Nm**	20 Nm**	15 Nm**

For stranded conductors using cable ferrules is recommended

*) bars of maximum width of 20 mm and maximum thickness of 5 mm can be fixed to M type screw terminals

**) using tension wrench is recommended

***) fuse switch disconnectors with V-terminals are equipped with steel V-clamp HM 10-120 on request

Apator takes responsibility for technical quality of V-terminals manufactured only by the company. Minimum tightening torque (M8 screw) for screws fixing fuse switch disconnector to busbar system – 12 Nm, recommended tightening torque for screws and nuts with property class 8.8 – 21 Nm.

FUSE RAIL PBS 00 (160 A, 690 V)

For 185 mm busbar system

Table 57. Technical data

Parameter		PBS 00
Size		00
Rated thermal current I_{th}	A	160
Rated voltage U_n	V	690
Rated insulation voltage U_i	V	1000
Rated frequency	Hz	50-60
Rated power dissipation	W	12
Rated short-circuit withstand current	kA	100
Mechanical durability	Number of cycles	100
IP degree of protection without fuse links installed	-	00
IP degree of protection with fuse links and fuse links shrouds installed *	-	20
Size of fuse links		00

Accessories on page 70, 71

*for more information about fuse links shrouds please see accessories



PBS 00-V

PBS 00-V-O

Table 58. Versions

Version		Weight	Article No.
PBS 00-V	cable terminals: V-terminals with V-clamps 25-150SW	2 kg	63-001417-001
PBS 00-SM	cable terminals: bridge terminals with bridgeclamps (S) 4-70 mm ² , screw terminals with M8 screws	1,9 kg	63-001417-002
PBS 00-SM/A2	cable terminals: bridge terminals with bridgeclamps (S) 4-70 mm ² , screw terminals with M8 screws*	1,9 kg	63-046101-001
PBS 00-V-O	cable terminals: V-terminals with V-clamps 25-150SW with fuse link shrouds	2,1 kg	63-001417-003
PBS 00-SM-O	cable terminals: bridge terminals with bridgeclamps (S) 4-70 mm ² , screw terminals with M8 screws with fuse link shrouds	2 kg	63-001417-004

* Stainless steel normals

Table 59. PBS 00 terminal clamps

Description	PBS 00			
Clamp	5-bridge clamp 2 x M5 x 25	M8 screw*	V- clamp 25-150 SW B	HM 10-120
Picture of clamp				
Drawing of clamp				
Cross-section of conductors	4 - 70 mm ²	Conductor with lug terminal max 185 mm ²	re ● 16 mm ² - 95 mm ² se ◆ 25 mm ² - 150 mm ² rm ⊗ 16 mm ² - 95 mm ² sm ⊕ 25 mm ² - 120 mm ²	re ● 10 mm ² - 70 mm ² se ◆ 25 mm ² - 120 mm ² rm ⊗ 10 mm ² - 70 mm ² sm ⊕ 25 mm ² - 95 mm ²
Tightening torque	3 Nm**	12 Nm**	20 Nm**	15 Nm**

For stranded conductors using cable ferrules is recommended

*) bars of maximum width of 20 mm and maximum thickness of 5 mm can be fixed to M type screw terminals

***) using tension wrench is recommended

****) fuse switch disconnectors with V-terminals are equipped with steel V-clamp HM 10-120 on request

Apator takes responsibility for technical quality of V-terminals manufactured only by the company. Minimum tightening torque (M8 screw) for screws fixing fuse switch disconnector to busbar system –12 Nm, recommended tightening torque for screws and nuts with property class 8.8 – 21 Nm.

PBS 1, PBS 2, PBS 3

Vertical fuse rails



PBS 2-V

PBS 3-V

With fuse links shrouds

Table 60. Technical data

Parameter		PBS 1	PBS 2	PBS 3
Rated thermal current $I_{th}=I_n$	A	250	400	630
Rated voltage U_n	V	690	690	690
Rated frequency	Hz	50 - 60	50 - 60	50 - 60
Peak current	kA	50	50	50
Rated power dissipation	W	max. 32	max. 45	max. 60
IP degree of protection	-	00	00	00
IP degree of protection with fuse links shrouds	-	20	20	20
Fuse link size	-	NH 1	NH 2	NH 3

Table 61. Versions

Version		Article No.
PBS 1 – 250 A		
PBS 1-M	Cable terminals: screw terminals with pressed nuts M12	63-500600-601
PBS 1-V	Cable terminals: V-terminals with V-clamps (35-300 mm ²)	63-500600-602
PBS 1-2V	Cable terminals: 2V-terminals with double V-clamps (2x50-240 mm ²)	63-500600-603
PBS 2 – 400 A		
PBS 2-M	Cable terminals: screw terminals with pressed nuts M12	63-500600-611
PBS 2-M/A2	Cable terminals: screw terminals with pressed nuts M12*	63-046102-001
PBS 2-V	Cable terminals: V-terminals with V-clamps (35-300 mm ²)	63-500600-612
PBS 2-2V	Cable terminals: 2V-terminals with double V-clamps (2x50 - 240 mm ²)	63-500600-613
PBS 3 – 630 A		
PBS 3-M	Cable terminals: screw terminals with pressed nuts M12	63-500600-621
PBS 3-M/A2	Cable terminals: screw terminals with pressed nuts M12*	63-046103-001
PBS 3-V	Cable terminals: V-terminals with V-clamps (35-300 mm ²)	63-500600-622
PBS 3-2V	Cable terminals: 2V-terminals with double V-clamps (2x50 - 240 mm ²)	63-500600-623

* Stainless steel normals

Table 62. PBS 1, PBS 2 terminal clamps

Description	PBS 1,2,3-V	PBS 1,2,3-2V	PBS 1,2,3-2V	PBS 1,2,3-M
Clamp	V-clamp 35-300SW-B	V-clamp 2/50-300SW-B	V-clamp HS 2/50-240-C*	M-screw M12**
Drawing of clamp				
Cross-section of conductors	V-clamp for direct fixing of conductor with bare end with cross-section of:			
	35 - 185 mm ²	35 - 240 mm ²	50 - 185 mm ²	50 - 240 mm ²
	35 - 240 mm ²	35 - 300 mm ²	50 - 240 mm ²	50 - 300 mm ²
Tightening torque	30 Nm	30 Nm	40 Nm	56 Nm

For stranded conductors using cable ferrules is recommended

*) if the fuse switch disconnecter with a 2V-type clamp is to be equipped with a steel V-clamp HS 2/50-240-C, it should be included in the order

**) Bars of maximum width of 40 mm and maximum thickness of 8 mm can be fixed to M type screw terminals when protective barrier between phases is installed.

Apator takes responsibility for technical quality of V-terminals manufactured only by the company. Minimum tightening torque (M10 screw) for screws fixing fuse switch disconnecter to busbar system – 32 Nm, recommended tightening torque for screws and nuts with property class 8.8 – 56 Nm.

PBS FUSE RAIL with lateral busbar terminal

(separation, coupling of busbar systems)

Table 63. Technical data

Parameter		PBS 2	PBS 3
Size		2	3
Rated thermal current I_{th}	A	400	630
Rated voltage U_n	V	690	690
Rated insulation voltage U_i	V	1000	1000
Rated frequency	Hz	50-60	50-60
Rated power dissipation	W	45	60
Rated short-circuit withstand current	kA	100	100
Mechanical durability	Number of cycles	100	100
IP degree of protection without fuse links installed	-		20
IP degree of protection with fuse links and fuse links shrouds installed*	-		20
Size of fuse links		2	3

Accessories on page 71, 72

*for more information about fuse links shrouds please see accessories



PBS 2-NR

PBS 3-NL

Table 64. Versions

Version		Weight	Article No.
PBS 2-NL	lateral busbar terminal - left side	2,2 kg	63-811673-011
PBS 2-NR	lateral busbar terminal - right side	2,2 kg	63-811673-031
PBS 3-NL	lateral busbar terminal - left side	3,0 kg	63-811673-021
PBS 3-NR	lateral busbar terminal - right side	3,0 kg	63-811673-041

Table 65. PBS with lateral busbar terminal clamps

Description	Drawing of clamp	PBS 2-NL (400 A)	PBS 2-NR (400 A)	PBS 3-NL (630 A)	PBS 3-NR (630 A)
Clamp		M12 screw	M12 screw	M12 screw	M12 screw
Cable terminal		Left side	Right side	Left side	Right side
Tightening torque		56 Nm	56 Nm	56 Nm	56 Nm

THREE PHASE CURRENT MEASUREMENT WITH FUSE RAIL PBS

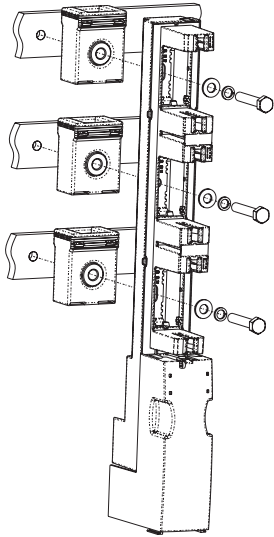

ONE PHASE CURRENT MEASUREMENT WITH FUSE RAIL PBS

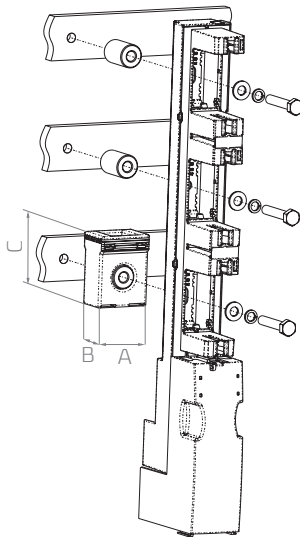

PBS 00/160 A fuse rails
CURRENT TRANSFORMER

A - max. 48mm
B - max. 35 mm
C - ~ 65 mm

DISTANCE SLEEVE

length 36 mm
Ø internal = 12,5 mm
Ø external = 22,5 mm

PBS 2 i 3 fuse rails
CURRENT TRANSFORMER

A - max. 90 mm
B - max. 35 mm
C - ~ 80 mm

DISTANCE SLEEVE

length 36 mm
Ø internal = 12,5 mm
Ø external = 22,5 mm

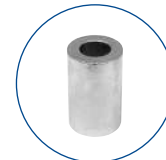

Distance sleeve



Current transformer

PBS 00/100 mm

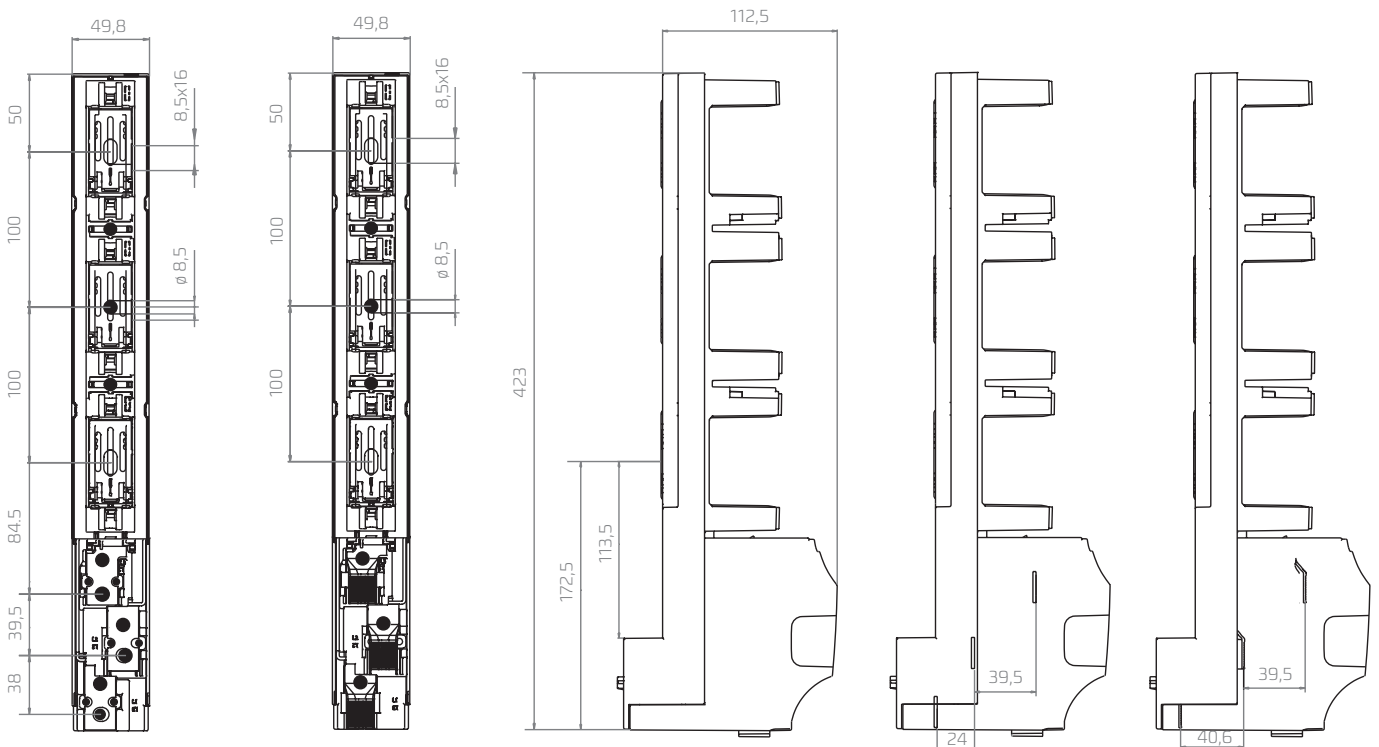

PBS 00

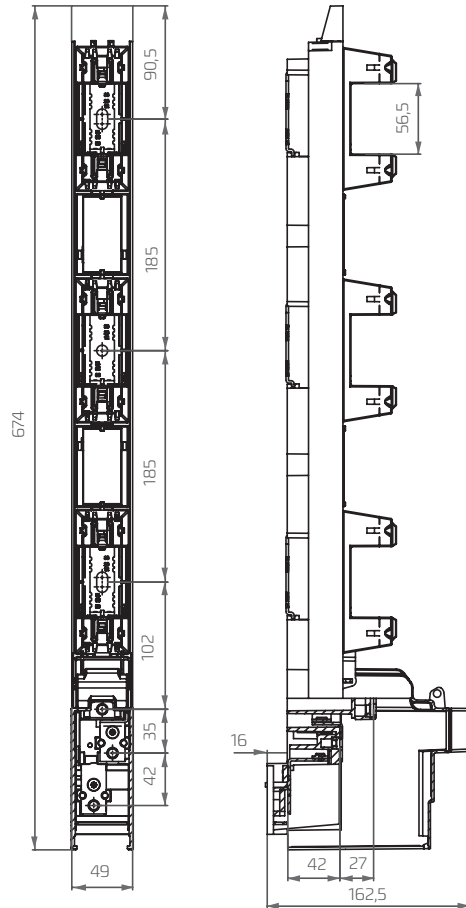
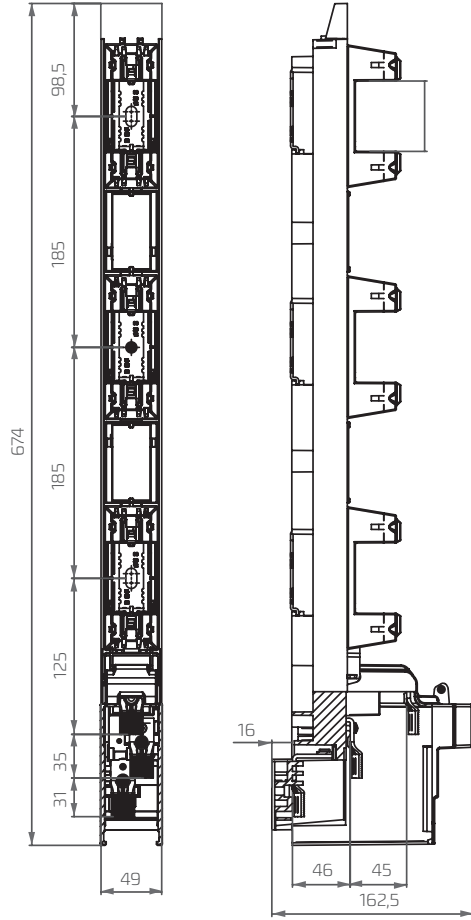

PBS 1,2,3 -M

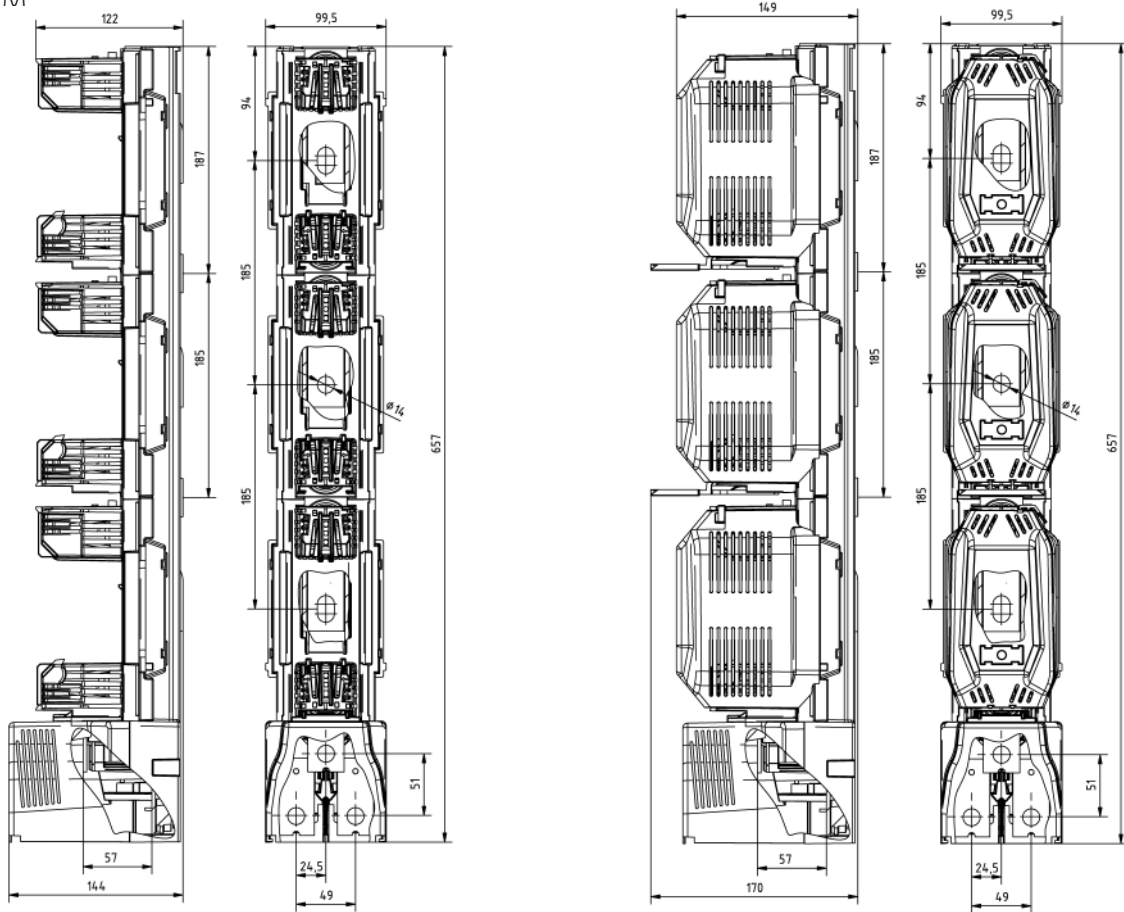

PBS 1,2,3-V, PBS 1,2,3-2V

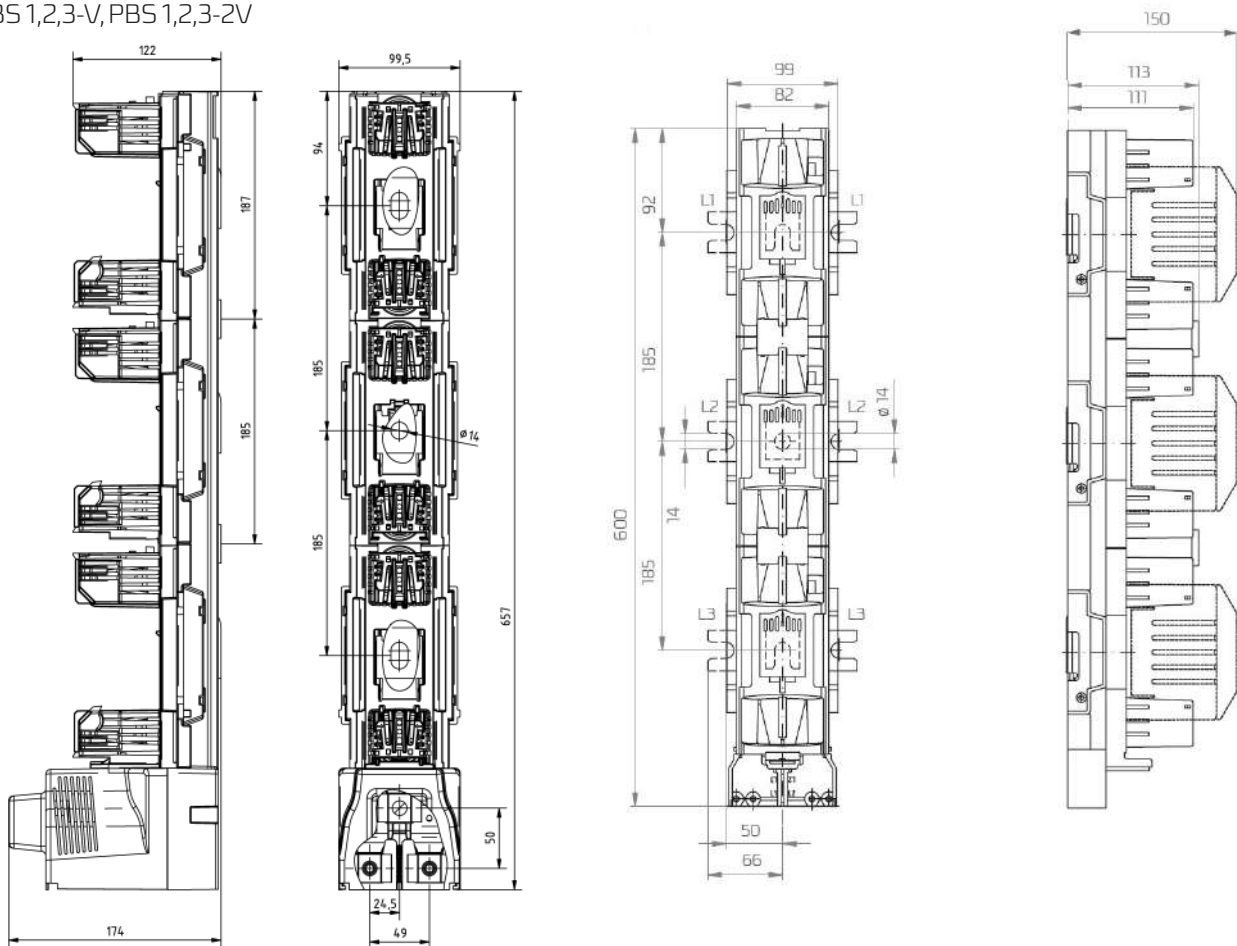

PBS 00, PBS 00/100 mm - accessories

Description	Article No.	Picture
M8 terminal screw, for connection of conductors with lug terminal (set - 3 pcs.)	53-082961-001	
Busbar shroud (polycarbonate) for busbar system 185 mm, Width 50 mm, length 562 mm, thickness 3 mm	1361400006T	
Hooked clamps for installation on to busbar system without drilled holes. (set - 3 pcs.). Tightening torque 8 Nm	53-001462-003	
Isolating pin for fixing the 50 mm busbar shroud, M8 (set - 2 pcs.)	1361400001T	
Distance sleeve for current transformer APA-W10 (Length 36 mm, outer diameter =22,5 mm, inner diameter =12,5 mm)	1115718010T	
5-Bridge clamp – fixed with 2 x M5 screw - for connection of conductors with cross-section 4 mm ² up to 70 mm ² (set – 3 pcs.)	53-002143-001	
V-shape clamp – 5-bridge clamp + V-shape saddle - for connection of sector-shaped conductors with cross-section 1,5 up to 70 mm ² (stranded) or 95 mm ² (solid) (set - 3 pcs.)	53-001462-001	
Universal earthing device for PBS 00, 1, 2, 3	1115281041T	
V- clamp HM-10-120. For connection of conductor with cross-section:	1119510077T	
10 - 70 mm ² 10 - 70 mm ²		
25 - 120 mm ² 25 - 95 mm ²		



PBS 00-V-O

PBS 00/100 mm

PBS 00/100 mm - accessories

Description	Article No.	Picture
Terminal shroud/adjusting shroud	53-945924-011	
Single adapter 100/185 enabling to install PBS 00/100 mm on busbar system 185 mm	1115281021	
Double adapter 100/185 enabling to install two PBS 00/100 mm units on busbar system 185 mm at perforation holes on busbar system every 100 mm	1115281022T	



PBS 00/100 mm

PBS 00 - accessories

Description	Article No.	Picture
Double adapter adjusts the height of PBS 00 to the height PBS 2,3	1115281024T	
Single distance adapter 185/185 for PBS 00/185 adjusts the front line to PBS 1, 2, 3 (set - 3 pcs.)	51-945160-011 (no. regard 1 pc.)	
Double distance adapter 185/185 for two units PBS 00/185 adjusts the front line to PBS 1, 2, 3 at perforation holes in busbar system every 100 mm (set - 3 pcs.)	52-945158-011 (no. regard 1 pc.)	
Fuse link shroud	51-001312-001	



PBS 00-V-0



PBS 2, PBS 3 - accessories

Description	Article No.	Picture
M10 terminal screw to PBS 2 for connection of conductors with lug terminal (set - 3 pcs.)	53-082961-002	
M12 terminal screw to PBS 3 for connection of conductors with lug terminal (set - 3 pcs.)	53-082961-003	
V-clamp For connection of conductor with cross-section	1119510081T	
35 - 120 mm ² 35 - 150 mm ²		
35 - 240 mm ² 35 - 300 mm ²		
V-clamp For connection of conductor with cross-section	1119510084T	
50 - 185 mm ² 50 - 240 mm ²		
50 - 240 mm ² 50 - 300 mm ²		
V-clamp For connection of two conductors with cross-section	1119510082T	
50 - 185 mm ² 50 - 240 mm ²		
50 - 240 mm ² 50 - 300 mm ²		
V-terminal lug for V-clamp for connection of conductors with cross-section 35 mm ² up to 240 mm ²	1119510002T	



PBS 2-V

 PBS 3-V
With fuse links shrouds

Description	Article No.	Picture
V-clamp HS (steel) for connection of two conductors with cross-section	1119510085T	
35-185 mm ²  35-240 mm ² 		
35-240 mm ²  35-300 mm ² 		
Busbar shroud (polycarbonate) for busbar system 185 mm, Width 100 mm, length 707 mm, thickness 2 mm	1361400007T	
Isolating pin for fixing the 100 mm busbar shroud, M12 (set – 2 pcs.)	1361400002T	
Extended terminal shroud. For use with terminal shroud	51-930313-01	
Distance sleeve for current transformer length 36 mm, outer diameter =22,5 mm, inner diameter =12,5 mm	115718010T	
Universal earthing device for ARS 00, 1, 2, 3	1115281041T	
Terminal shroud for PBS 2-V and PBS 2-2V	51-500600-106	
Terminal shroud for PBS 2-M	51-500600-101	
Link shroud	51-500600-108	



RBK pro

Horizontal fuse switch disconnectors

- designed for distribution of electricity and protection of electrical equipment against short-circuits and overloads with industrial fuse links.

APPLICATIONS

RBK pro fuse switch disconnectors are designed for distribution of electricity and protection of electrical equipment against short-circuits and overloads with industrial fuse links. They are conforming to EN 60947-1, EN 60947-3, IEC 60947-1, IEC 60947-3 standards. They are intended for installation in low voltage distribution boards, cable and metering cabinets.

CONSTRUCTION

- thermoplastic parts of **RBK pro** fuse switch disconnectors are made of fibre glass strengthened polyamide with halogen free flame retardant added and have highest possible flammability class – V0,
- **RBK pro** fuse switch disconnectors consist of following parts:
 - three pole main base with spring-loaded contacts designed for connection of circular or sector-shaped conductors, conductors with lug terminals or bars,
 - removable cover with fuse links,
- arc chambers with steel deionization plates over top contacts,
- silver plated contacts providing low power loss.

MOUNTING

- on mounting plate
 - RBK 000 pro, RBK 00 pro, RBK 1 pro, RBK 2 pro, RBK 3,
- DIN rail
 - single: RBK 000 pro,
 - double: RBK 00 pro,
- on to busbar systems:
 - 60 mm RBK 000 pro-S, RBK 00 pro-S, RBK 1 pro-S, RBK 2 pro-S, installation on to busbar system with hooked clamps, placed inside fuse,
 - 60 mm RBK 3-S installation on busbar system using adapter with three M10 screws,
 - 100 mm (RBK 2-S, RBK 1 pro-S) installation on to busbar system with hooked clamps placed inside fuse.

OPERATING CONDITIONS

- to be installed in the room free of any dust, aggressive or explosive gases,
- altitude up to 2000 meters above sea level,
- outdoor – in cabinets with protection degree > IP34,
- ambient temperature from -25°C to +55°C,
- relative humidity of the air should not be higher than 50% at temperature of +40°C.

FUNCTIONALITY

- making and breaking operations should be done with determined movement,
- possible connection of circular or sector-shaped conductors with bare ends (V-terminals, 2V-terminals) or conductors with lug terminals (screw terminals),
- voltage test performed through test holes in fuse link cover,
- fuse links state monitoring.

CONFORMITY WITH STANDARDS

Table 66. RBK pro fuse switch disconnectors technical data

Parameter		RBK 000 pro RBK 000 pro-S					RBP 000 pro			RBP 000 pro-S			RBK 00 pro			RBK 00 pro-S						
Rated thermal current $I_{th}^{1)}$	A	160					125			125			160			160						
Rated voltage U_n	V	690					690			690			690			690						
Utilization category	-	AC-23B	AC-22B	AC-22B	AC-21B	DC-21B	AC-23B	AC-21B	DC-22B	AC-23B	AC-22B	DC-22B	AC-23B	DC-22B	DC-21B	AC-23B	AC-22B	AC-22B				
Rated switching current I_e	A	100	100	160	160	160	125	125	100	125	125	100	160	160	160	160	160	160				
Rated switching voltage U_e	V	400	690	400	690	250	400	690	250	400	690	250	690	250	440	400	690	250				
Rated short circuit withstand current	690 V	25				25/ 250V	50		25/ 250V	35		25/ 250V	80		25/250V	100		25/ 250V				
	500 V	80					-			-			-									
	400 V	-					80			80			100									
Rated short circuit making current	690 V	25				25/ 250V	50		25/ 250V	35		25/ 250V	80		25/250V	100		25/ 250V				
	500 V	80					-			-			-									
	400 V	-					80			80			100									
Rated insulation voltage U_i	V	1000					1000			1000			1000			1000						
Rated impulse withstand voltage U_{imp}	kV	8					6			6			8			8						
Rated frequency	Hz	50-60			-		50-60		-		50-60		-		50-60		-		50-60		-	
Mechanical durability	Number of cycles	2000		1600			1600			1600			1600			1600						
Electrical durability		300		200			200			200			200			200						
IP degree of protection	IP	20					20*			20*			20			20						
Weight	kg	~0,6, ~0,9					~0,5			~0,7			~0,7			~0,9						
Size of fuse links	-	000					000			000			00			00						

*from the front IP30

¹⁾ I_{th} - thermal current of fuse switch disconnector without external enclosure, installed outdoors
(In case of the installation of fuse switch disconnectors in enclosures then load factor should be considered)

Parameter		RBK 00 pro-V120			RBK 1 pro		RBK 1 pro-S			RBK 2 pro RBK 2 pro-S			RBK 3 pro			RBK 3 pro-S		
Rated thermal current $I_{th}^{1)}$	A	160			250		250			400			630			630		
Rated voltage U_n	V	690			690		690			690			690			690		
Utilization category	-	AC-23B	AC-22B	DC-22B	AC-23B	DC-22B	AC-23B	AC-22B	DC-22B ²⁾	AC-23B	DC-22B	DC-21B	AC-23B	AC-22B	DC-21B	AC-23B	AC-22B	DC-21B
Rated switching current I_e	A	160	160	160	250	250	250	250	250	400	400	400	630	630	630	630	630	630
Rated switching voltage U_e	V	400	690	250	690	250	400	690	250	690	220	440	400	690	440	400	500	690
Rated short circuit withstand current	690 V	kA	100	25/ 250V	80	25/ 250V	80		25/ 250V	80	20/250V, 15/440V	80		35/ 440V	80			
	500 V				-		-			-		-						
	400 V				100		100			100		-						
Rated short circuit making current	690 V	kA	100	25/ 250V	80	25/ 250V	80		25/ 250V	80	20/250V, 15/440V	80		35/ 440V	80			
	500 V				-		-			-		-						
	400 V				100		100-			100		-						
Rated insulation voltage U_i	V	1000			1000		1000			1000			1000					
Rated impulse withstand voltage U_{imp}	kV	8			8		8			12			12					
Rated frequency	Hz	50-60	-	50-60	-	50-60	-	50-60	-	50-60	-	50-60	-	50-60	-	50-60		
Mechanical durability	Number of cycles	1600			1600		1600			1000			1000			1000		
Electrical durability		200			200		200			200			200			200		
IP degree of protection	IP	20			20		20			20			20*			20*		
Weight	kg	~0,9			~2		~2,5			~3, ~4,5			~4,3			~4,9		
Size of fuse links	-	00			1		1			2			3			3		

*from the front IP30

¹⁾ I_{th} - thermal current of fuse switch disconnecter without external enclosure, installed outdoors
(In case of the installation of fuse switch disconnecters in enclosures then load factor should be considered)

- RBK 2 switch disconnecter with solid links 400 A
- rated short-time withstand current $1s I_{cw} = 13$ kA
- rated short-circuit making capacity $I_{cm} = 8$ kA
- RBK 1000 - (RBK 3 switch disconnecter with solid links 1000 A)
- rated short-time withstand current $1s I_{cw} = 12,6$ kA
- rated short-circuit making capacity $I_{cm} = 25,2$ kA
- rated thermal current $I_{th} = 1000$ A when connected on to busbars 50 x 10 mm
- utilization category AC-21

RBK 000 pro (160 A, 690 V)



RBK 000 pro
for installation on mounting plate

Table 67. Technical data

Parameter		RBK 000 pro / RBK 000 pro-S				
Rated thermal current $I_{th}^{(1)}$	A	160				
Rated voltage U_n	V	690				
Utilization category	-	AC-23B	AC-22B	AC-22B	AC-21B	DC-21B
Rated switching current I_e	A	100	100	160	160	160
Rated switching voltage U_e	V	400	690	400	690	250
Rated short circuit making current	690 V	kA	25			25/ 250V
	500 V		80			
	400 V		-			
Rated short circuit withstand current	690 V	kA	25			25/ 250V
	500 V		80			
	400 V		-			
Rated insulation voltage U_i	V	1000				
Rated impulse withstand voltage U_{imp}	kV	8				
Rated frequency	Hz	50-60				-
Mechanical durability	Number of cycles	2000			1600	
Electrical durability		300			200	
IP degree of protection	IP	20				
Weight	kg	~0,6, ~0,9				
Size of fuse links	-	000				

¹⁾ I_{th} - thermal current of fuse switch disconnectors without external enclosure, installed outdoors
(In case of the installation of fuse switch disconnectors in enclosures then load factor should be considered)

Table 68. Versions

RBK 000 pro/160 A		Cable terminal	Article No.	
For installation on mounting plate				
RBK 000 pro	for connection of round conductors	S-bridge clamps	63-823191-011	
RBK 000 pro-E	for connection of round conductors, possible installation on DIN rail	S-bridge clamps	63-823191-051	
RBK 000 pro-M	for connection of round conductors with lug terminals	M8 screws	63-823191-021	
RBK 000 pro-M-E	for connection of round conductors with lug terminals, possible installation on DIN rail	M8 screws	63-823191-061	
RBK 000 pro-W	for connection of round conductors, lengthened terminal shrouds	S-bridge clamps	63-823191-071	
RBK 000 pro-W-M	for connection of round conductors with lug terminals, lengthened terminal shrouds	M8 screws	63-823191-081	
For installation on to 60 mm busbar system				
APASYS 60	RBK 000 pro-SD	Cable terminal – bottom, for connection of round conductors	S-bridge clamps	63-823234-031
	RBK 000 pro-SG	Cable terminal – top, for connection of round conductors	S-bridge clamps	63-823234-011
	RBK 000 pro-SD-M	Cable terminal – bottom, for connection of conductors with lug terminals	M8 screws	63-823234-041
	RBK 000 pro-SG-M	Cable terminal – top, for connection of conductors with lug terminals	M8 screws	63-823234-021

Table 69. RBK 000 pro terminal clamps

Description	Clamp	Drawing of clamp	Cross-section of conductors	Cu bar	Tightening torque	Dimensions and spacing of holes for installation of RBK 000 on mounting plate
RBK 000 pro	S-bridge clamp 2 x M5 x 16		Cu/Al conductor 1,5 ÷ 35 mm ²	maximum bar width 15 mm	3 Nm*	
	M8 x 16 screw		conductor with lug terminal up to 70 mm ²		10 Nm*	

For stranded conductors using cable ferrules is recommended
*using of tension wrench is recommended



RBK 000 pro-E
for mounting on DIN rail



RBK 000 pro
for installation on mounting plate
with additional terminal shrouds



RBK 000 pro-W
for installation on mounting plate
with extended terminal shrouds



RBK 000 pro-SG (top cable terminals)
RBK 000 pro-SD (bottom cable terminals)
for installation on to 60 mm busbar system

RBP 000 pro (125 A, 690 V) for mounting

- on plate
- on double DIN rail

RBP 000 pro-S (125 A, 690 V) for installation onto 60 mm busbar system

- system of protective covers provides touch protection
- possible installation of distribution board's protective panel at depth of 32 mm or 70 mm
- built-in hooked clamps provide fast installation onto busbar system
- top/bottom cable terminal



RBP 000 pro-S

Table 70. Technical data

Parameter		RBP 000 pro			RBP 000 pro-S		
Rated thermal current $I_{th}^{1)}$	A	125			125		
Rated voltage U_n	V	690			690		
Utilization category	-	AC-23B	AC-21B	DC-22B	AC-23B	AC-22B	DC-22B
Rated switching current I_e	A	125	125	100	125	125	100
Rated switching voltage U_e	V	400	690	250	400	690	250
Rated short circuit making current	690 V	50			35		
	500 V	-			-		
	400 V	80			80		
Rated short circuit withstand current	690 V	50			35		
	500 V	-			-		
	400 V	80			80		
Rated insulation voltage U_i	V	1000			1000		
Rated impulse withstand voltage U_{imp}	kV	6			6		
Rated frequency	Hz	50-60		-	50-60		-
Mechanical durability	Number	1600			1600		
Electrical durability	of cycles	200			200		
IP degree of protection	IP	20*			20*		
Weight	kg	~0,5			~0,7		
Size of fuse links	-	000			000		

¹⁾ I_{th} - thermal current of fuse switch disconnector without external enclosure, installed outdoors
(In case of the installation of fuse switch disconnectors in enclosures then load factor should be considered)

Table 71. Versions

RBP 000 pro		Cable terminal	Article No.
For mounting on plate			
RBP 000 pro	for connection of round conductors	frame clamps	63-823267-001
for mounting on double DIN rail			
RBP 000 pro-E-125 mm	double DIN rail with spacing of 125 mm	frame clamps	63-823267-002
RBP 000 pro-E-150 mm	double DIN rail with spacing of 150 mm	frame clamps	63-823267-003
APASYS 60	RBP 000 pro-S		
	For installation on to 60 mm busbar system		
	RBP 000 pro-SG	cable terminal-top, for connection of conductors with bare ends	frame clamps
RBP 000 pro-SD	cable terminal-bottom, for connection of conductors with bare ends	frame clamps	63-823427-002

Table 72. RBP 000 pro, RBP 000 pro-S terminal clamps

Description	Cable terminal	Drawing of clamp	Cross-section of conductors	Tightening torque
RBP 000 pro RBP 000 pro-S	frame clamps		2,5 - 50 mm ²	6 Nm*

For stranded conductors using cable ferrules is recommended

*using of tension wrench is recommended

Saves space in the switchboard

RBP 000 pro-S (**RBP 000-pro**) width dimensions is equal to half the width of **RBK 00 pro-S** (**RBK 00 pro**), so we can install more disconnectors (keeping a certain width of the switchboard) to protect individual circuits in the switchboard.

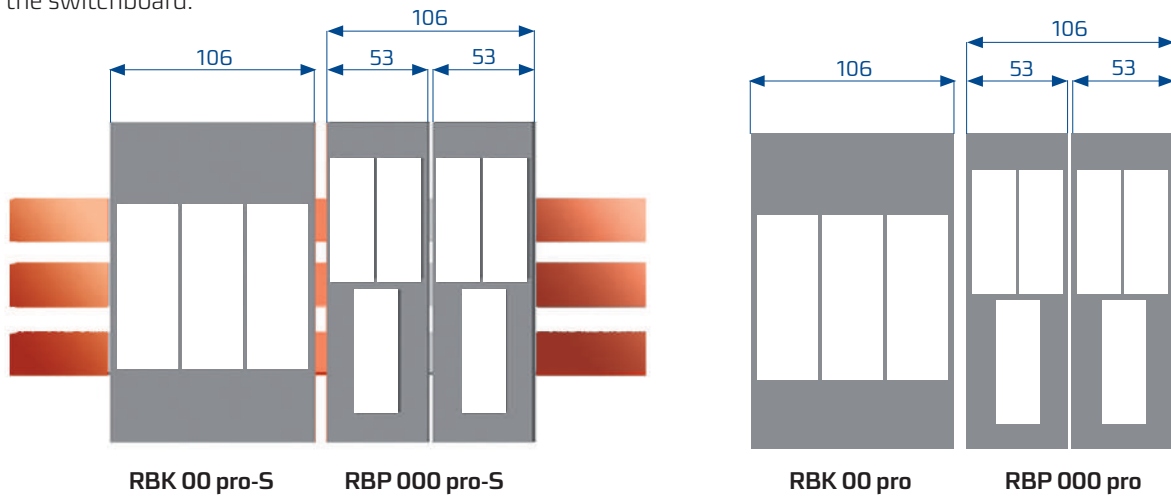

Fuse switch disconnectors **RBP 000 pro-S** are designed for installation of distribution board's protective panels at two depths:

- covering system at 70 mm depth
- covering system at 32 mm depth

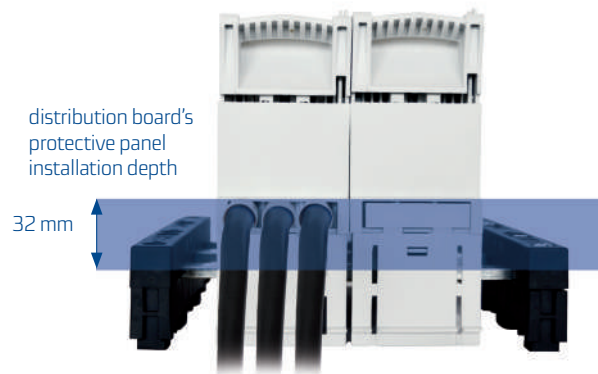
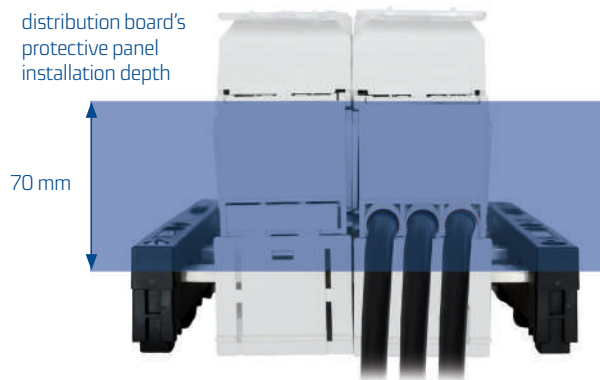

Fuse switch disconnectors **RBP 000 pro-S** are manufactured in two versions depending on type of cable terminal

- **RBP 000 pro-SD**-with bottom cable terminal
- **RBP 000 pro-SG**-with top cable terminal

with cables connected to the bottom cable terminal
RBP 000 pro- SD



Fuse switch disconnector **RBP 000 pro-S** has special cavity in it's main base encasing busbar system's support.



Cavity for busbar system's support

It is possible to install **microswitch indicating** position open/close fuse switch disconnectors.

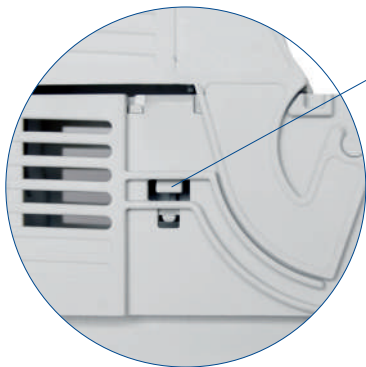

hole for leading of wires connected to microswitch

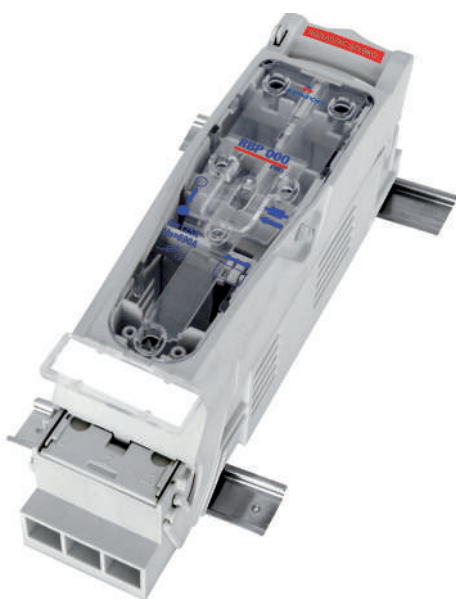

Fuse switch disconnector **RBP 000 pro - E 125 mm** for mounting on double DIN rail



RBP 000 pro mounting on plate

RBP 000 pro, RBP 000 pro-S

RBK 00 pro (160 A, 690 V)

Table 73. Technical data

Parameter		RBK 00 pro		
Rated thermal current $I_{th}^{1)}$	A	160		
Rated voltage U_n	V	690		
Utilization category	-	AC-23B	DC-22B	DC-21B
Rated switching current I_o	A	160	160	160
Rated switching voltage U_o	V	690	250	440
Rated short circuit making current	690 V	kA	80	25/250V
	500 V		-	
	400 V		100	
Rated short circuit withstand current	690 V	kA	80	25/250V
	500 V		-	
	400 V		100	
Rated insulation voltage U_i	V	1000		
Rated impulse withstand voltage U_{imp}	kV	8		
Rated frequency	Hz	50-60	-	
Mechanical durability	Number of cycles	1600		
Electrical durability	Number of cycles	200		
IP degree of protection	IP	20		
Weight	kg	~0,7		
Size of fuse links	-	00		

¹⁾ I_{th} - thermal current of fuse switch disconnecter without external enclosure, installed outdoors
(In case of the installation of fuse switch disconnectors in enclosures then load factor should be considered)



RBK 00 pro

Table 74. Versions

RBK 00 pro/160 A		Cable terminal	Article No.
For installation on mounting plate			
RBK 00 pro	for connection of round conductors	S-bridge clamps	63-823256-111
RBK 00 pro-M	for connection of conductors with lug terminals	M8 screws	63-823256-121
RBK 00 pro-V	for connection of sector-shaped conductors	V-shape clamps	63-823256-131
RBK 00 pro-W	for connection of round conductors lengthened terminal shrouds	S-bridge clamps	63-823256-141
RBK 00 pro-M-W	for connection of conductors with lug terminals, lengthened terminal shrouds	M8 screws	63-823256-151
RBK 00 pro-V-W	for connection of sector-shaped conductors, lengthened terminal shrouds	V-shape clamps	63-823256-161
for mounting on double DIN rail			
RBK 00 pro-E-125mm	double DIN rail with spacing of 125 mm	S-bridge clamps/ M8 screws/ V-shape clamps	63-823256-190
RBK 00 pro-E-150mm	double DIN rail with spacing of 150 mm	S-bridge clamps/ M8 screws/ V-shape clamps	63-823256-191

Table 75. RBK 00 pro terminal clamps

Description	Clamp	Drawing of clamp	Cross-section of conductors	Cu bar	Tightening torque	Dimensions and spacing of holes for installation of RBK 00 pro on mounting plate
RBK 00 pro	S-bridge clamp 2 x M5 x 16		Cu/Al conductor 4÷50 mm ²	maximum bar width 20 mm	3 Nm*	
	M8 x 16 screw		conductor with lug terminal up to 70 mm ²		10 Nm*	
	V-shape clamp 2 x M5 x 20		2) 4 mm ² - 70 mm ² 4 mm ² - 95 mm ² 1) 1,5 mm ² - 2,5 mm ²		3 Nm*	

For stranded conductors using cable ferrules is recommended
 *using of tension wrench is recommended

RBK 00 pro



RBK 00 pro-W



Fuse switch disconnecter **RBK 00 pro-W**
with additional terminal shrouds

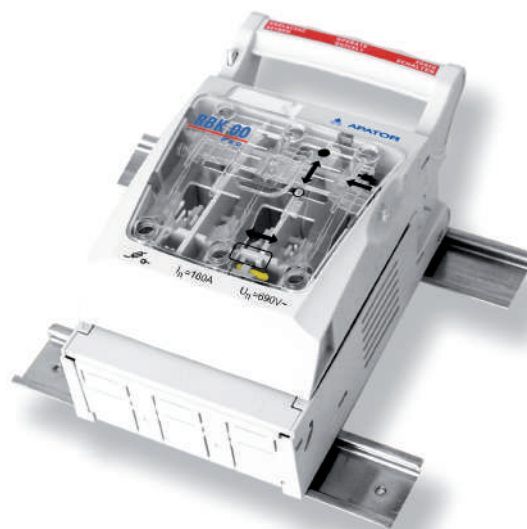

Fuse switch disconnecter **RBK 00 pro-E**
for mounting on double DIN rail

FUSE SWITCH DISCONNECTORS FOR INSTALLATION ONTO 60 mm BUSBAR SYSTEM RBK 00 pro-S

- system of protective covers provides touch protection
- possible installation of distribution board's protective panel at depth of 32 mm or 70 mm
- built-in hooked clamps provide fast installation onto busbar system
- top/bottom cable terminal

Table 76. Technical data

Parameter		RBK 00 pro-S		
Rated thermal current $I_{th}^{1)}$	A	160		
Rated voltage U_n	V	690		
Utilization category	-	AC-23B	AC-22B	DC-22B
Rated switching current I_e	A	160	160	160
Rated switching voltage U_e	V	400	690	250
Rated short circuit making current	690 V	kA	100	25/ 250V
	500 V			
	400 V			
Rated short circuit withstand current	690 V	kA	100	25/ 250V
	500 V			
	400 V			
Rated insulation voltage U_i	V	1000		
Rated impulse withstand voltage U_{imp}	kV	8		
Rated frequency	Hz	50-60	-	
Mechanical durability	Number of cycles	1600		
Electrical durability	Number of cycles	200		
IP degree of protection	IP	20		
Weight	kg	~0,9		
Size of fuse links	-	00		

¹⁾ I_{th} - thermal current of fuse switch disconnecter without external enclosure, installed outdoors
(In case of the installation of fuse switch disconnectors in enclosures then load factor should be considered)



RBK 00 pro-S

Table 77. Versions

	RBK 00 pro-S	Cable terminal	Article No.
APASY5 60	For installation on to 60 mm busbar system		
	RBK 00 pro-SG-M	cable terminal – top, for connection of conductors with lug terminals	M8 screws 63-823259-121
	RBK 00 pro-SD-M	cable terminal – bottom, for connection of conductors with lug terminals	M8 screws 63-823259-141
	RBK 00 pro-SG-R	cable terminal-top, for connection of conductors with bare ends	frame clamps 63-823259-151
	RBK 00 pro-SD-R	cable terminal-bottom, for connection of conductors with bare ends	frame clamps 63-823259-161

Table 78. RBK 00 pro-S terminal clamps

Description	Clamp	Drawing of clamp	Cross-section of conductors	Cu bar	Tightening torque
RBK 00 pro-SGM RBK 00 pro-SDM	M8 x 16 screw		conductor with lug terminal up to 70 mm ²	maximum bar width 20 mm	10 Nm*
RBK 00 pro-SGR RBK 00 pro-SDR	frame clamps		4 ÷ 95 mm ²	-	6 Nm* 3 Nm*

For stranded conductors using cable ferrules is recommended
*using of tension wrench is recommended

Fuse switch disconnectors **RBK 00 pro-S** are designed for installation of distribution board's protective panels at two depths:

- covering system at 70 mm depth
- covering system at 32 mm depth

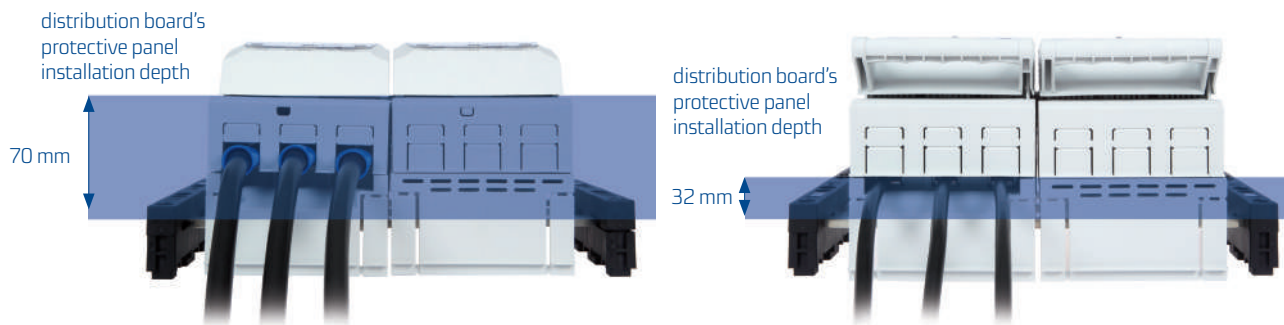

Fuse switch disconnectors **RBK 00 pro-S** are manufactured in two versions depending on type of cable terminal

- **RBK 00 pro-SD**-with bottom cable terminal
- **RBK 00 pro-SG**-with top cable terminal



Fuse switch disconnecter **RBK 00 pro-S** has special cavity in it's main base encasing busbar system's support.



Cable terminals:

M8 screw terminal (RBK 00 pro-SDM, RBK 00 pro-SGM)

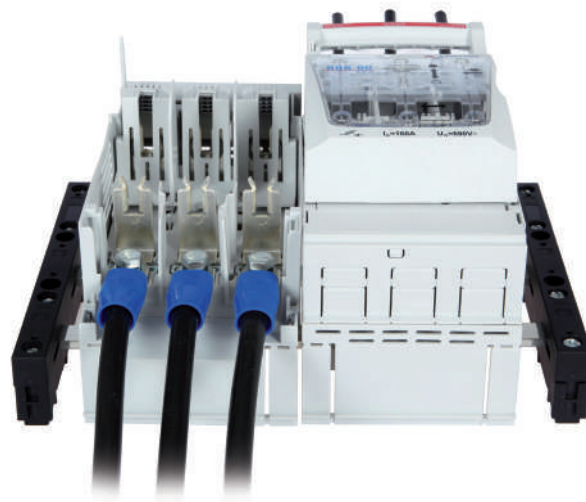

Frame clamp (RBK 00 pro-SDR, RBK 00 pro-SGR)

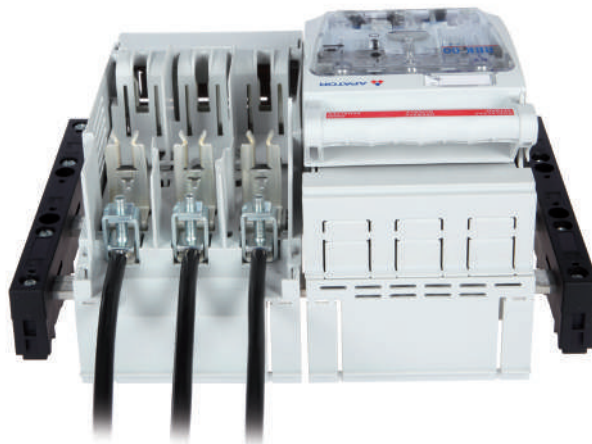

It is possible to install **microswitch indicating** position in fuse switch disconnectors **RBK 00 pro-S**.



hole for leading
of wires connected
to microswitch



RBK 00 pro V 120 (160 A, 690 V)

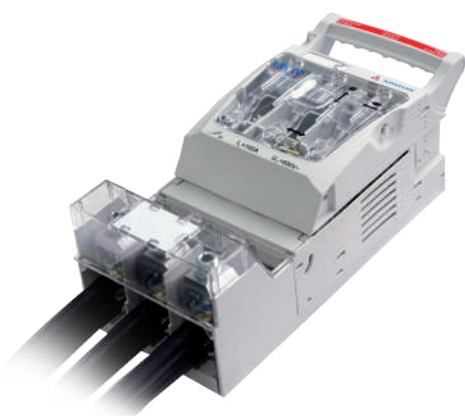

RBK 00 pro V 120

Table 79. Technical data











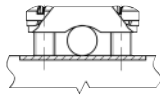

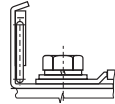

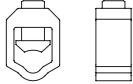
Parameter		RBK 00 pro-V120		
Rated thermal current $I_{th}^{1)}$	A	160		
Rated voltage U_n	V	690		
Utilization category	-	AC-23B	AC-22B	DC-22B
Rated switching current I_e	A	160	160	160
Rated switching voltage U_e	V	400	690	250
Rated short circuit making current	690 V	kA	100	25/ 250V
	500 V			
	400 V			
Rated short circuit withstand current	690 V	kA	100	25/ 250V
	500 V			
	400 V			
Rated insulation voltage U_i	V	1000		
Rated impulse withstand voltage U_{imp}	kV	8		
Rated frequency	Hz	50-60	-	
Mechanical durability	Number of cycles	1600		
Electrical durability	Number of cycles	200		
IP degree of protection	IP	IP20		
Weight	kg	~0,9		
Size of fuse links	-	00		

¹⁾ I_{th} - thermal current of fuse switch disconnecter without external enclosure, installed outdoors
(In case of the installation of fuse switch disconnectors in enclosures then load factor should be considered)

Table 80. Versions

RBK 00 pro V 120		Article No.
For installation on mounting plate		
RBK 00 pro - V120	for connection of conductors with bare ends (top terminals- S-bridge clamps, bottom terminals – V-clamps)	63-823341-011
RBK 00 pro - V120 - M	for connection of conductors with bare ends (top terminals- M8 screws, bottom terminals – V-clamps)	63-823341-021
RBK 00 pro - P	for connection of conductors with bare ends (top terminals- S-bridge clamps, bottom terminals – Prism clamps)	63-823341-031
RBK 00 pro - P - M	for connection of conductors with bare ends (top terminals- M8 screws, bottom terminals – Prism clamps)	63-823341-041
RBK 00 pro 2 x V120	for connection of conductors with bare ends (top terminals- S-bridge clamps, bottom terminals – double V-clamps)	63-823341-051
RBK 00 pro 2 x V120 - M	for connection of conductors with bare ends (top terminals- M8 screws, bottom terminals – double V-clamps)	63-823341-061

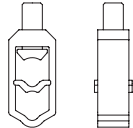
Table 81. RBK 00 pro-V120 terminal clamps

Clamp	Picture of a clamp	Drawing of clamp	Cross-section of conductors	Cu bar	Tightening torque	
terminals on the consumer side	S-bridge clamp 2 x M5 x 16			maximum bar width 20 mm	3 Nm*	
	M8 x 16 screw				conductor with lug terminal up to 70 mm ²	10 Nm*
cable terminals	V-clamp			 ** 25÷150 mm ²	-	20 Nm*
				 ** 16÷95 mm ²		
	HM10-120			 ** 10 - 70 mm ²		15 Nm*
				 ** 25 - 120 mm ²  ** 25 - 95 mm ²		
	double V-clamp			 ** 2 x (25÷120 mm ²)		20 Nm*
				 ** 2 x (16÷95 mm ²)		

*using of tension wrench is recommended

**for stranded conductors using cable ferrules is recommended

New features of cable terminals

- connection of one or two sector-shaped conductors with cross-section up to 120 mm²
- connection of two round conductors with bare ends and cross-section up to 70 mm²

Space saving

- possible reduction of external width of cable distribution cabinet to width of a fuse switch disconnecter

Efficient current circuit

- no screw or riveted connection between contact and cable terminal (uniform design of current circuit ensures lower power loss and operating temperature)

Safety

- fuse cover and cable terminal cover sealing
- extension of covering of conductors connected to cable terminals by installation of additional covers

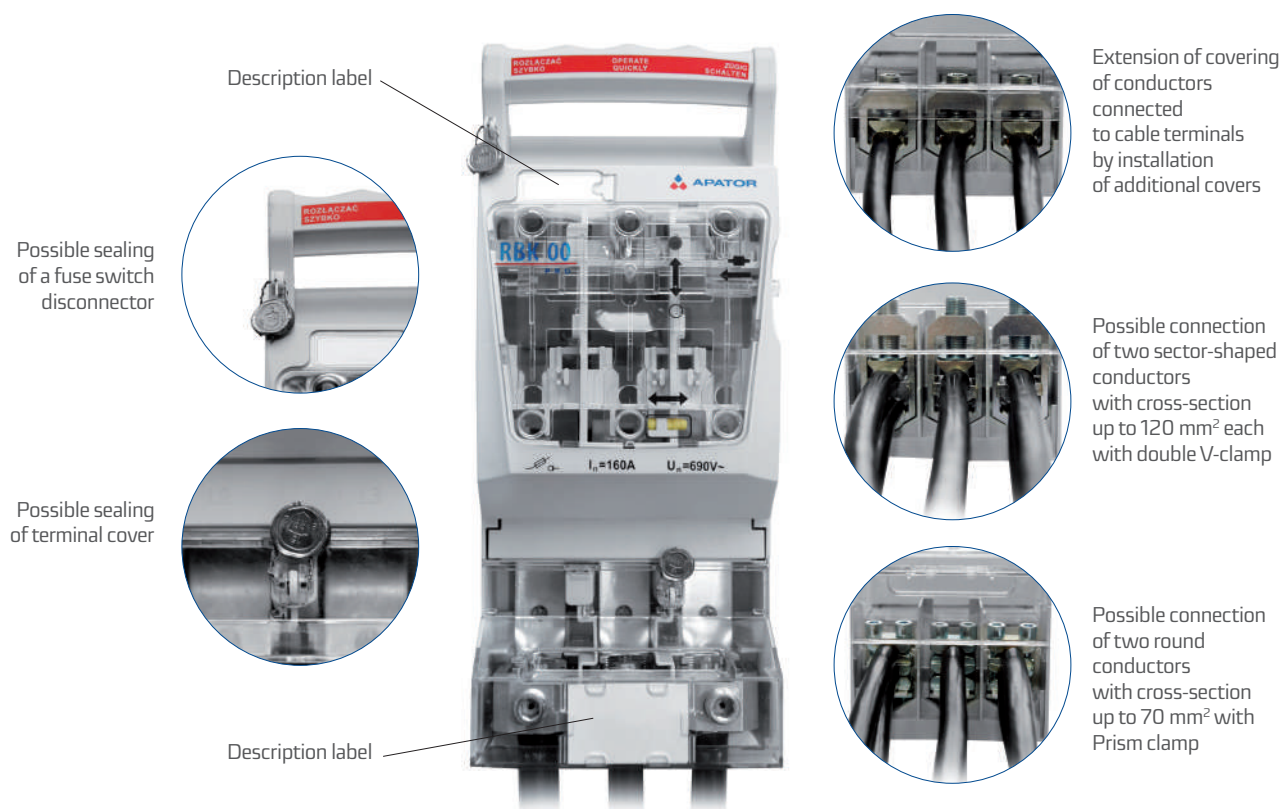

Extended covering of conductors connected to cable terminal

For extension of covering of conductors connected to cable terminals, for example: to fully cover cables in cable distribution cabinet, any required number of additional covers could be installed (article number of additional extending cover: 51-930849-011) . Cover length - 50 mm.



Additional covers
(51-930849-011)

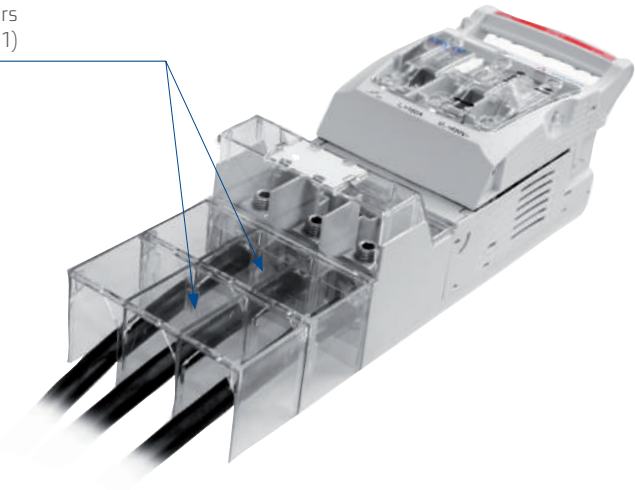

RBK 00 pro V120

RBK 00 pro-V120 with V-clamp for connection of sector-shaped conductors with cross-section up to 120 mm²

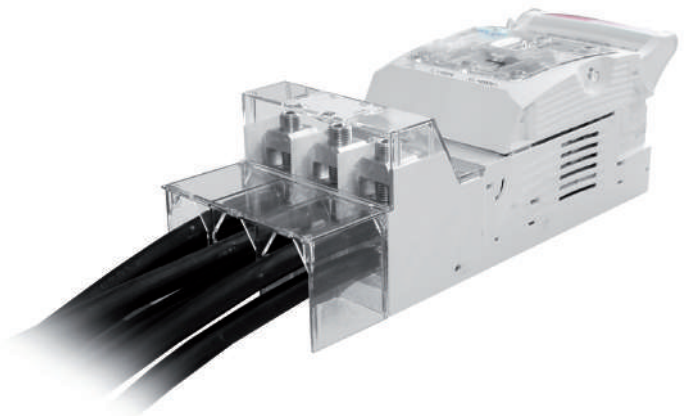

RBK 00 pro 2 x V120 with double V-clamp for connection of two sector-shaped conductors with cross-section up to 120 mm² each

RBK 1 pro (250 A, 690 V)



RBK 1 pro
for installation
on mounting plate

Table B2. Technical data

Parameter		RBK 1 pro		RBK 1 pro-S		
Rated thermal current $I_{th}^{(1)}$	A	250		250		
Rated voltage U_n	V	690		690		
Utilization category	-	AC-23B	DC-22B	AC-23B	AC-22B	DC-22B ²⁾
Rated switching current I_e	A	250	250	250	250	250
Rated switching voltage U_e	V	690	250	400	690	250
Rated short circuit making current	690 V	80	25/ 250V	80	-	25/ 250V
	500 V	-		-		
	400 V	100		100		
Rated short circuit withstand current	690 V	80	25/ 250V	80	-	25/ 250V
	500 V	-		-		
	400 V	100		100-		
Rated insulation voltage U_i	V	1000		1000		
Rated impulse withstand voltage U_{imp}	kV	8		8		
Rated frequency	Hz	50-60	-	50-60	-	
Mechanical durability	Number of cycles	1600		1600		
Electrical durability		200		200		
IP degree of protection	IP	IP20		IP20		
Weight	kg	~2		~2,5		
Size of fuse links	-	1		1		

¹⁾ I_{th} - thermal current of fuse switch disconnector without external enclosure, installed outdoors
(In case of the installation of fuse switch disconnectors in enclosures then load factor should be considered)

Table B3. Versions

RBK 1 pro/250 A				
For installation on mounting plate		Cable terminals	Article No.	
RBK 1 pro	For connection of round conductors	S-bridge clamps	63-811748-011	
RBK 1 pro-M	For connection of conductors with lug terminals	Screws	63-811748-021	
RBK 1 pro-V	For connection of sector-shaped conductors	V-clamps	63-811748-031	
RBK 1 pro VG	For connection of round conductors, top terminals - V-terminals, bottom terminals - S-bridge terminals	V- clamps / S-bridge clamps	63-811784-011	
RBK 1 pro VG-M	For connection of round conductors, top terminals - V-terminals, bottom terminals - screw terminals	V- clamps /screws	63-811784-021	
RBK 1 pro VD	For connection of round conductors, top terminals - S-bridge terminals, bottom terminals - V-terminals	S-bridge clamps / V- clamps	63-811784-031	
RBK 1 pro VD-M	For connection of round conductors, top terminals - screw terminals, bottom terminals - V-terminals	Screws / V-clamps	63-811784-041	
RBK 1 pro-S				
For installation on to busbar system		Cable terminals	Article No.	
60 mm busbar system				
APASYS 60	RBK 1 pro-SG 60	Top cable terminals, for connection of round conductors	S-bridge clamps	63-811750-011
	RBK 1 pro-SD 60	Bottom cable terminals, for connection of round conductors	S-bridge clamps	63-811750-021
	RBK 1 pro-SG-M 60	Top cable terminals, for connection of sector-shaped conductors	Screws	63-811750-051
	RBK 1 pro-SD-M 60	Bottom cable terminals, for connection of conductors withlug terminals	Screws	63-811750-061
	RBK 1 pro-SG-V 60	Top cable terminals, for connection of sector-shaped conductors	V-clamps	63-811750-091
	RBK 1 pro-SD-V 60	Bottom cable terminals, for connection of sector-shaped conductors	V-clamps	63-811750-101

Table 84. Versions

RBK 1 pro-S		Cable terminals	Article No.
For installation on to busbar system			
100 mm busbar system			
RBK 1 pro-SG 100	Top cable terminals, for connection of round conductors	S-bridge clamps	63-811750-031
RBK 1 pro-SD 100	Bottom cable terminals, for connection of round conductors	S-bridge clamps	63-811750-041
RBK 1 pro-SG-M 100	Top cable terminals, for connection of conductors with lug terminals	Screws	63-811750-071
RBK 1 pro-SD-M 100	Bottom cable terminals, for connection of conductors with lug terminals	Screws	63-811750-081
RBK 1 pro-SG-V 100	Top cable terminals, for connection of sector-shaped conductors	V-clamps	63-811750-111
RBK 1 pro-SD-V 100	Bottom cable terminals, for connection of sector-shaped conductors	V-clamps	63-811750-121

Table 85. RBK 1 pro terminal clamps

Description	RBK 1 pro	RBK 1 pro-M	RBK 1 pro-V
Clamp	S-bridge clamp 2 x M8 x 30	M10x25 screw	V-clamp HS 35-300-C
Picture of a clamp			
Drawing of a clamp			
Cross-section of conductors	Cu/Al conductor 35 ÷ 120 mm ²	conductor with lug terminal up to 120 mm ²	V-clamp for direct fixing of conductor with bare end with cross-section of: 35 - 150 mm ² 50 - 240 mm ² 35 - 185 mm ² 50 - 300 mm ²
Cu bar	maximum bar width 35 mm		
Tightening torque	10 Nm*	20 Nm*	30 Nm*
Dimensions and spacing of holes for installation of RBK 1 pro on mounting plate			

*using of tension wrench is recommended

**for stranded conductors using cable ferrules is recommended



RBK 1 pro
for installation on mounting plate



RBK 1 pro-SG
RBK 1 pro-SD
for installation on to busbar system



RBK 1 pro
for installation on mounting plate,
with additional terminal shrouds



RBK 1 pro VD-M
for installation on mounting plate,
picture of fuse switch disconnecter
without fuse links cover and terminal shrouds,
top cable terminal - M screws,
bottom cable terminal - V-clamps,
(RBK 1 pro VG-M - bottom cable terminal - M screws,
top cable terminal - V-clamps)

RBK 1 pro

RBK 2 pro (400 A, 690 V)

Table 86. Technical data

Parameter		RBK 2 pro / RBK 2 pro-S		
Rated thermal current I_{th}	A	400		
Napięcie znamionowe U_n	V	690		
Utilization category	-	AC-23B	DC-22B	DC-21B
Rated switching current I_e	A	400	400	400
Rated switching voltage U_e	V	690	220	440
Rated short circuit making current	690 V	kA	80	20/250V,15/440V
	500 V			
	400 V		100	
Rated short circuit withstand current	690 V	kA	80	20/250V,15/440V
	500 V		-	
	400 V		100	
Rated insulation voltage U_i	V	1000		
Rated impulse withstand voltage U_{imp}	kV	12		
Rated frequency	Hz	50-60	-	
Mechanical durability	Number of cycles	1000		
Electrical durability	Number of cycles	200		
IP degree of protection	IP	20		
Weight	kg	~3,~4,5		
Size of fuse links	-	2		



RBK 2-V pro
for installation on mounting plate

Table 87. Versions

RBK 2 pro/400 A		Cable terminal	Article No.	
For installation on mounting plate				
RBK 2 pro	for connection of round conductors	S-bridge clamps	63-811685-011	
RBK 2 pro-V	for connection of sector-shaped conductors	V-clamps	63-811685-071	
RBK 2 pro-2V	for connection of sector-shaped conductors	double V-clamps	63-811685-081	
RBK 2 pro-M	or connection of conductors with lug terminals	M10 screws	63-811685-061	
RBK 2 pro-VG	for connection of sector-shaped / round conductors top terminals - V-clamps, bottom terminals - S-bridge clamps	V-clamps / S-bridge clamps	63-811685-201	
RBK 2 pro-VG-M	for connection of sector-shaped conductors / conductors with lug terminals top terminals - V-clamps, bottom terminals - screw terminals	V-clamps / S-bridge clamps	63-811685-202	
RBK 2 pro-VD	for connection of round / sector-shaped conductors top terminals - S-bridge clamps, bottom terminals - V-clamps	V-clamps / S-bridge clamps	63-811685-203	
RBK 2 pro-VD-M	for connection of conductors with lug terminals / sector-shaped conductors top terminals - screw terminals, bottom terminals - V-clamps	screws / V-clamps	63-811685-204	
For installation on to 60 mm busbar system				
APASYS 60	RBK 2 pro-SD-M 60	Bottom cable terminals, for connection of conductors with lug terminals	M10 screws	63-811686-061
	RBK 2 pro-SG-M 60	Top cable terminals, for connection of conductors with lug terminals	M10 screws	63-811686-051
	RBK 2 pro-SD-V 60	Bottom cable terminals, for connection of sector-shaped conductors	V-clamps	63-811686-101
	RBK 2 pro-SG-V 60	Top cable terminals, for connection of sector-shaped conductors	V-clamps	63-811686-091
	RBK 2 pro-SD-2V 60	Bottom cable terminals, for connection of sector-shaped conductors	double V-clamps	63-811686-141
	RBK 2 pro-SG-2V 60	Top cable terminals, for connection of sector-shaped conductors	double V-clamps	63-811686-131
For installation on to 100 mm busbar system				
RBK 2 pro-SD-M 100	Bottom cable terminals, for connection of conductors withlug terminals	M10 screws	63-811686-081	
RBK 2 pro-SG-M 100	Top cable terminals, for connection of conductors with lug terminals	M10 screws	63-811686-071	
RBK 2 pro-SD-V 100	Bottom cable terminals, for connection of sector-shaped conductors	V-clamps	63-811686-121	
RBK 2 pro-SG-V 100	Top cable terminals, for connection of sector-shaped conductors	V-clamps	63-811686-111	
RBK 2 pro-SD-2V 100	Bottom cable terminals, for connection of sector-shaped conductors	double V-clamps	63-811686-161	
RBK 2 pro-SG-2V 100	Top cable terminals, for connection of sector-shaped conductors	double V-clamps	63-811686-151	

Table 88. RBK 2 pro terminal clamps

Description	RBK 2 pro			
	Clamp	S-bridge clamp 2 x M8 x 30	M10 x 30 screw	V-clamp 35-300SW-B
Drawing of clamp				
Cross-section of conductors	Cu/Al conductor 50 ÷ 185 mm ²	conductor with lug terminal up to 240 mm ²	V-clamp for direct fixing of conductor with bare end with cross-section:	
			35 - 185 mm ² 35 - 240 mm ²	35 - 185 mm ² 35 - 240 mm ²
Cu bar	maximum bar width 35 mm			
Tightening torque	10 Nm*	20 Nm*	30 Nm*	40 Nm*
Dimensions and spacing of holes for installation of RBK 2 on mounting plate				

For stranded conductors using cable ferrules is recommended

*using of tension wrench is recommended



RBK 2 pro-V
for installation
on mounting plate,
cable terminals: V-clamps



RBK 2 pro-2V
for installation
on mounting plate,
cable terminals: double V-clamps



RBK 2 pro-SG (top cable terminal: M10 screws)
RBK 2 pro-SD (bottom cable terminal: M10 screws)
for installation on to busbar systems



RBK 2 pro-SG-V (top cable terminal: double V-clamp)
RBK 2 pro-SD-V (bottom cable terminal: double V-clamp)
for installation on to busbar systems
cable terminals: V-clamps



RBK 2 pro-SG-2V (top cable terminal: V-clamp)
RBK 2 pro-SD-2V (bottom cable terminal: V-clamp)
for installation on to busbar systems
cable terminal: double V-clamps

RBK 3 pro (630 A, 690 V)

Table 89. Technical data

Parameter		RBK 3 pro			RBK 3 pro-S		
		AC-23B	AC-22B	DC-21B	AC-23B	AC-22B	DC-21B
Rated thermal current $I_{th}^{(1)}$	A	630			630		
Rated voltage U_n	V	690			690		
Utilization category	-	AC-23B	AC-22B	DC-21B	AC-23B	AC-22B	DC-21B
Rated switching current I_e	A	630	630	630	630	630	630
Rated switching voltage U_e	V	400	690	440	400	500	690
Rated short circuit making current	690 V	kA	80	35/ 440V	80	-	
	500 V		-			-	
	400 V		-			-	
Rated short circuit withstand current	690 V	kA	80	35/ 440V	80	-	
	500 V		-			-	
	400 V		-			-	
Rated insulation voltage U_i	V	1000			1000		
Rated impulse withstand voltage U_{imp}	kV	12			12		
Rated frequency	Hz	50-60	-		50-60		
Mechanical durability	Number of cycles	1000			1000		
Electrical durability	Number of cycles	200			200		
IP degree of protection	IP	20			20		
Weight	kg	~4,3			~4,9		
Size of fuse links	-	3			3		

¹⁾ I_{th} - thermal current of fuse switch disconnecter without external enclosure, installed outdoors
(In case of the installation of fuse switch disconnectors in enclosures then load factor should be considered)



RBK 3 pro
main version
for installation
on mounting plate

Table 90. Versions

RBK 3 pro		Cable terminal	Article No.
For installation on mounting plate			
RBK 3 pro	for connection of round conductors	S-bridge clamps	63-811761-011
RBK 3 pro-M	for connection of conductors with lug terminals	M12 screws	63-811761-021
RBK 3 pro-M-2xVD	cable terminals: for connection of conductors with lug terminals - top M screws, for connection of sector-shaped conductors - bottom V-clamps	M12 screws/V-shape terminals	63-811761-031
APASYS60 RBK 3 pro, RBK 3 pro-S for installation on 60 mm busbar system			
RBK 3 pro-SD	bottom cable terminals, for connection of round conductors	S-bridge clamps	63-028802-001
RBK 3 pro-SG	top cable terminals, for connection of round conductors	S-bridge clamps	63-028802-002
RBK 3 pro-SD-M	bottom cable terminals, for connection of conductors with lug terminals	M12 screws	63-028802-003
RBK 3 pro-SG-M	top cable terminals, for connection of conductors with lug terminals	M12 screws	63-028802-004

Table 91. RBK 3 pro terminal clamps

Description	RBK 3 pro			Dimensions and spacing of holes for installation of RBK 3 pro on mounting plate
	S-bridge clamp 2 x M8 x 35	M12 x 30 screw	V-clamp 35-300SW-B	
Drawing of clamp				
Cross-section of conductors	Cu/Al conductor 50 ÷ 185 mm ²	conductor with lug terminal up to 240 mm ²	V-clamp for direct fixing of two conductors with bare ends with cross-section of:	
Cu bar	maximum bar width 35 mm		35 - 185 mm ² 35 - 240 mm ² 35 - 240mm ² 35 - 300 mm ²	
Tightening torque	10 Nm*	20 Nm*	30 Nm*	

For stranded conductors using cable ferrules is recommended
*using of tension wrench is recommended

Electronic fuse monitoring module - description

- L1, L2, L3 diodes are flashing - all three phases are supplied, all fuse links are operational. Relay contacts: [21..22] - closed; [13..14] - opened
- L1, L2, L3 diodes are blinking - all three phases are supplied, fuse links operated Relay contacts: [21..22] - opened; [13..14] - closed
- L1, L2, L3 diodes are off - two or more phases are not supplied or fuse links are removed. Relay contacts: [21..22] - opened; [13..14] - closed



RBK 00-X
with electronic fuse monitoring module

Parameters

- operating voltage AC - 400 ÷ 690 V, 40 ÷ 60 Hz;
- relay parameters 5A, 250 V~

CAUTION!

For use only with fuse-links with non-isolated gripping lugs!

Electronic fuse monitoring module versions according to power supply connection

RBK 00-XT - for RBK 00 installed on mounting plate,

with power supply connected to top cable terminals

RBK 00-X - for RBK 00 installed on mounting plate,

with power supply connected to bottom cable terminals

RBK 00S-X - for RBK 00 installed on to 60 mm busbar system

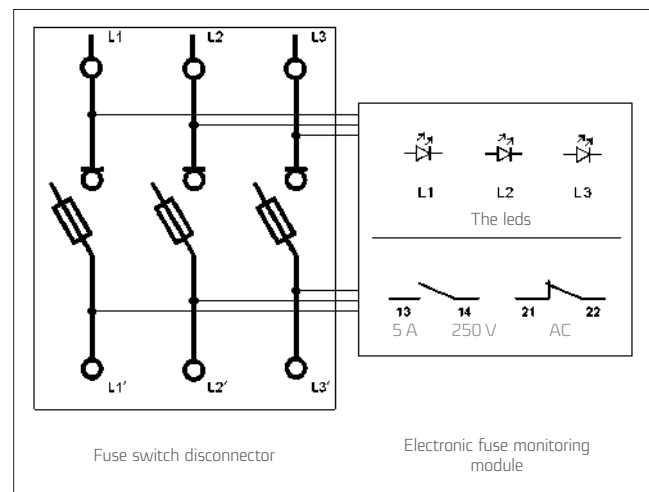

disconnecter contact position during normal operation

Table 92. Versions

Versions with electronic fuse monitoring module, cable terminals - S-bridge clamps		
RBK 00 pro-XT	For installation on mounting plate, power supply connected to top cable terminals	63-823304-011
RBK 00 pro-X	For installation on mounting plate, power supply connected to top bottom terminals	63-823304-021
RBK 00 pro-SG-X	For installation on to 60 mm busbar system, top cable terminals, busbar power supply	63-823345-011
RBK 00 pro-SD-XT	For installation on to 60 mm busbar system, bottom cable terminals, busbar power supply	63-823345-021
RBK 1 pro-XT	For installation on mounting plate, power supply connected to top cable terminals	63-811785-011
RBK 1 pro-X	For installation on mounting plate, power supply connected to top bottom terminals	63-811785-021
RBK 1 pro-SG 60-X	For installation on to 60 mm busbar system, top cable terminals, busbar power supply	63-811787-011
RBK 1 pro-SD 60-XT	For installation on to 60 mm busbar system, bottom cable terminals, busbar power supply	63-811787-021
RBK 1 pro-SG 100-X	For installation on to 100 mm busbar system, top cable terminals, busbar power supply	63-811787-031
RBK 1 pro-SD 100-XT	For installation on to 100 mm busbar system, bottom cable terminals, busbar power supply	63-811787-041
RBK 2 pro-XT	For installation on mounting plate, power supply connected to top cable terminals	63-811786-011
RBK 2 pro-X	For installation on mounting plate, power supply connected to top bottom terminals	63-811786-021
RBK 2 pro-SG 60-X	For installation on to 60 mm busbar system, top cable terminals, busbar power supply	63-811788-011
RBK 2 pro-SD 60-XT	For installation on to 60 mm busbar system, bottom cable terminals, busbar power supply	63-811788-021
RBK 2 pro-SG 100-X	For installation on to 100 mm busbar system, top cable terminals, busbar power supply	63-811788-031
RBK 2 pro-SD 100-XT	For installation on to 100 mm busbar system, bottom cable terminals, busbar power supply	63-811788-041



RBK

Fuse switch disconnectors

- intended for distribution of electricity and protection
- of electrical equipment against short-circuits and overloads,
- with industrial fuse links

APPLICATIONS

RBK fuse switch disconnectors are designed for distribution of electricity and protection of electrical equipment against short-circuits and overloads with industrial fuse links. They are conforming to EN 60947-1, EN 60947-3, IEC 60947-1, IEC 60947-3 standards. They are intended for installation in low voltage distribution boards, cable and metering cabinets.

CONSTRUCTION

- thermoplastic parts of **RBK** fuse switch disconnectors are made of fibre glass strengthened polyamide with halogen free flame retardant added and flammability class V2,
- **RBK** fuse switch disconnectors consist of following parts:
 - three pole main base with spring-loaded contacts designed for connection of circular or sector-shaped conductors, conductors with lug terminals or bars,
 - removable cover with fuse links,
- arc chambers with steel deionization plates over top contacts,
- silver plated contacts providing low power loss.

MOUNTING

- on mounting plate
 - RBK 00, RBK 1,
- on to 60 mm busbar system installation on to busbar system, with hooked clamps.

OPERATING CONDITIONS

- to be installed in the room free of any dust, aggressive or explosive gases,
- altitude up to 2000 meters above sea level,
- outdoor – in cabinets with protection degree > IP34,
- ambient temperature from -25°C to +55°C,
- relative humidity of the air should not be higher than 50% at temperature of +40°C.

FUNCTIONALITY

- making and breaking operations should be done with determined movement,
- possible connection of circular or sector-shaped conductors with bare ends (V-terminals, 2V-terminals) or conductors with lug terminals (screw terminals),
- voltage test is performed through test holes in fuse link cover.

Conformity with standards

EN 60947-1 EN 60947-3 HD 60269-2

Table 93. RBK fuse switch disconnectors technical data

Parameter			RBK 00	RBK 1
Rated thermal current $I_{th}^{1)}$	A		160	250
Rated voltage U_n	V		690	690
Utilization category	-		AC-22B	AC-22B
Rated switching current I_e	A		160	250
Rated switching voltage U_e	V		690	690
Rated short circuit making current	690 V	kA	80	80
	500 V		-	-
	400 V		100	100
Rated short circuit withstand current	690 V	kA	80	80
	500 V		-	-
	400 V		100	100
Rated insulation voltage U_i	V		1000	1000
Rated power dissipation U_{imp}	kV		8	8
Rated frequency	Hz		50-60	50-60
Mechanical durability	Number of cycles		1600	1600
Electrical durability			200	200
IP degree of protection	IP		20*	20*
Weight	kg		~0,65	~2
Size of fuse links PN/IEC	-		00	1

*from the front IP30

¹⁾ I_{th} - thermal current of fuse switch disconnector without external enclosure, installed outdoors (In case of the installation of fuse switch disconnectors in enclosures then load factor should be considered)

RBK 00 (160 A, 690 V)

Table 94. Technical data

Parameter			RBK 00
Rated thermal current $I_{th}^{1)}$	A		160
Rated voltage U_n	V		690
Utilization category	-		AC-22B
Rated switching current I_e	A		160
Rated switching voltage U_e	V		690
Rated short circuit making current	690 V	kA	80
	500 V		-
	400 V		100
Rated short circuit withstand current	690 V	kA	80
	500 V		-
	400 V		100
Rated insulation voltage U_i	V		1000
Rated impulse withstand voltage U_{imp}	kV		8
Rated frequency	Hz		50-60
Mechanical durability	Number of cycles		1600
Electrical durability			200
IP degree of protection	IP		IP20
Weight	kg		~0,65
Size of fuse links	-		00

¹⁾ I_{th} - thermal current of fuse switch disconnecter without external enclosure, installed outdoors
(In case of the installation of fuse switch disconnectors in enclosures then load factor should be considered)



RBK 00
for installation on mounting plate

Table 95. Versions

RBK 00/160 A		Cable termina	Article No.
RBK 00	for connection of round conductors	S-bridge clamps	63-823333-111
RBK 00-M	for connection of conductors with lug terminals	M8 screws	63-823333-121
RBK 00-V	for connection of sectorshaped conductors	V-shape clamps	63-823333-131
RBK 00-W	for connection of round conductors, lenghtened terminal shrouds	S-bridge clamps	63-823333-141
RBK 00-M-W	for connection of conductors with lug terminals, lenghtened terminal shrouds	M8 screws	63-823333-151
RBK 00-V-W	for connection of sectorshaped conductors, lenghtened terminal shrouds	V-shape clamps	63-823333-161

Table 96. RBK 00 terminal clamps

Description	RBK 00			Dimensions and spacing of holes for installation of RBK 00 on mounting plate
Clamp	S-bridge clamp 2 x M5 x 16	M8 x 16 screw	V-shape clamp 2 x M5 x 20	
Drawing of clamp				
Cross-section of conductors	Cu/Al conductor 4 ÷ 50 mm ²	conductor with lug terminal up to 70 mm ²	① ● 1,5 mm ² - 2,5 mm ² ② ● 4 mm ² - 70 mm ² ● 4 mm ² - 95 mm ²	
Cu bar	maximum bar width 20 mm			
Tightening torque	3 Nm*	10 Nm*	3 Nm*	

For stranded conductors using cable ferrules is recommended
*using of tension wrench is recommended

RBK 1 (250 A, 690 V)



RBK 1
for installation on mounting plate



Table 97. Technical data

Parameter		RBK 1
Rated thermal current $I_{th}^{(1)}$	A	250
Rated voltage U_n	V	690
Utilization category	-	AC-22B
Rated switching current I_e	A	250
Rated switching voltage U_e	V	690
Rated short circuit making current	690 V	80
	500 V	-
	400 V	100
Rated short circuit withstand current	690 V	80
	500 V	-
	400 V	100
Rated insulation voltage U_i	V	1000
Rated impulse withstand voltage U_{imp}	kV	8
Rated frequency	Hz	50-60
Mechanical durability	Number of cycles	1600
Electrical durability	Number of cycles	200
IP degree of protection	IP	IP20
Weight	kg	~2
Size of fuse links	-	1

Table 98. Versions

RBK 1/250 A		Cable terminals	Article No.
RBK 1	For connection of round conductors	S-bridge clamps	63-811779-011
RBK 1-M	For connection of conductors with lug terminals	Screws	63-811779-021
RBK 1-V	For connection of sector-shaped conductors	V-clamps	63-811779-031
RBK 1 VG	For connection of round conductors, top terminals -V-terminals, bottom terminals - S-bridge terminals	V-clamps / S-bridge clamps	63-811784-051
RBK 1 VG-M	For connection of round conductors, top terminals -V-terminals, bottom terminals - screw terminals	V-clamps / screws	63-811784-061
RBK 1 VD	For connection of round conductors, top terminals -S-bridge terminals, bottom terminals - V-terminals	S-bridge clamps / V-clamps	63-811784-071
RBK 1 VD-M	For connection of round conductors, top terminals-screw terminals, bottom terminals - V-terminals	screw terminals / V-clamps	63-811784-081

Table 99. RBK 1 terminal clamps

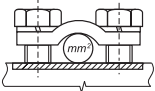
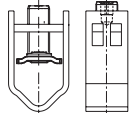
Description	RBK 1	RBK 1-M	RBK 1-V
Clamp	S-bridge clamp 2 x M8 x 30	M10x25 screw	V-clamp V HS 35-300-C
Picture of a clamp			
Drawing of a clamp			
Cross-section of conductors	Cu/Al conductor 35 ÷ 120 mm ²	conductor with lug terminal up to 120 mm ²	V-clamp for direct fixing of conductor with bare end with cross-section of: 35 - 185 mm ²  35 - 240 mm ² 
Cu bar	maximum bar width 35 mm		
Tightening torque	10 Nm*	20 Nm*	30 Nm*

Dimensions and spacing of holes for installation of RBK 1 on mounting plate

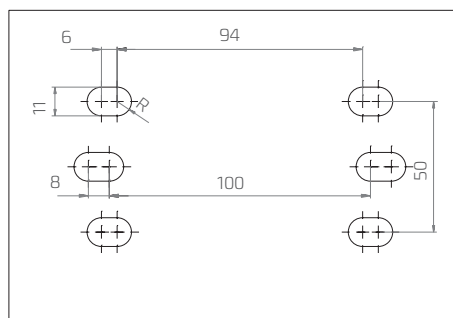

*using of tension wrench is recommended

**for stranded conductors using cable ferrules is recommended



RBK 1
for installation on mounting plate



RBK 1
for installation on mounting plate, with additional terminal shrouds



RBK 1VD-M
for installation on mounting plate, picture of fuse switch disconnecter without fuse links cover and terminal shrouds, top cable terminal - M screws, bottom cable terminal - V-clamps, (RBK 1 VG-M - bottom cable terminal - M screws, top cable terminal - V-clamps)

RBK 000 pro
RBK 000 pro-E

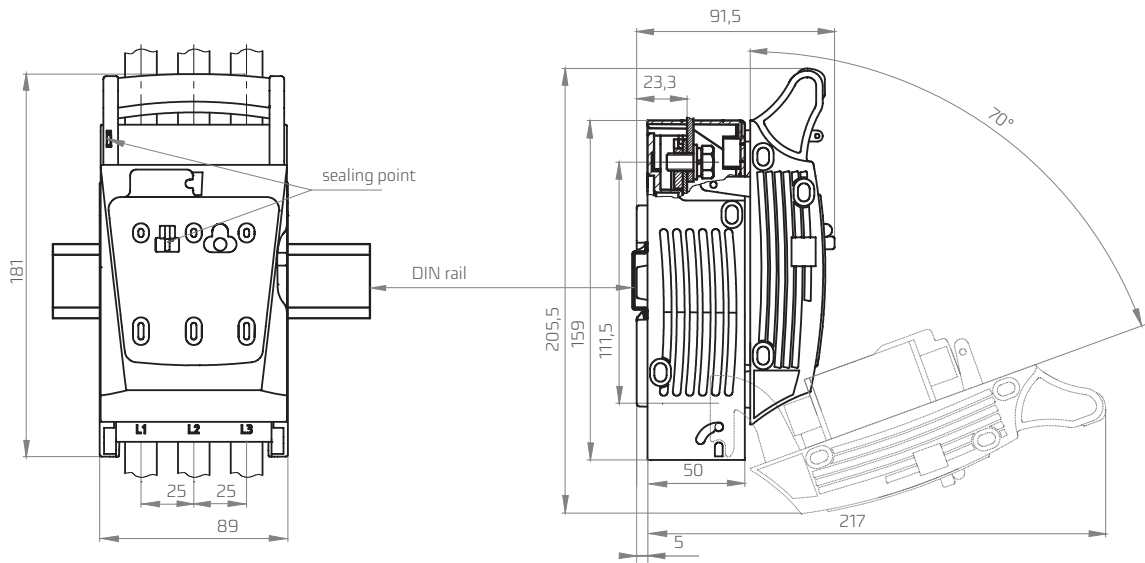

RBK 000 pro-O

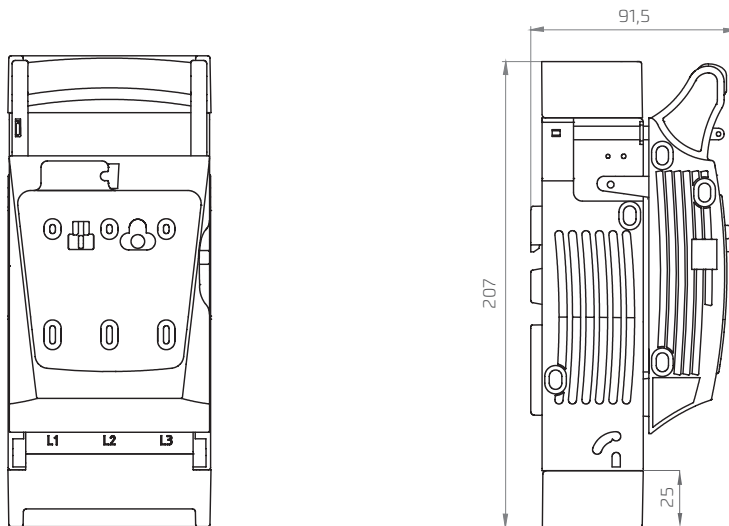

RBK 000 pro-W

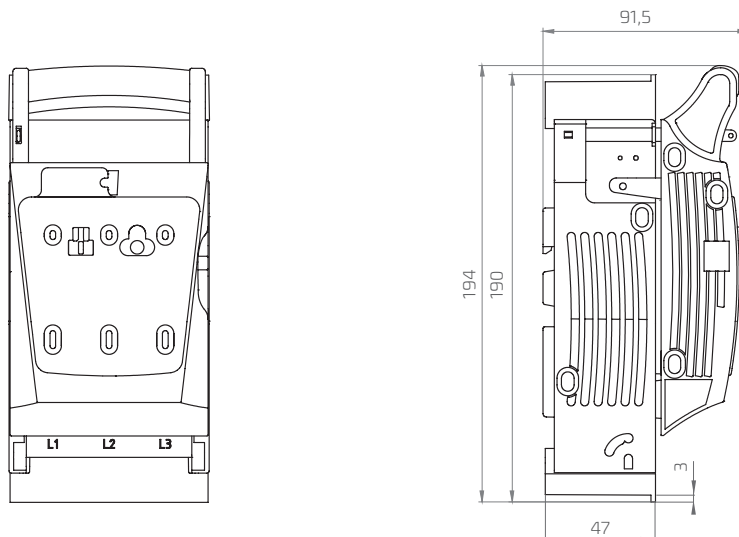

RBK 000 pro-SG top cable terminal
 RBK 000 pro-SD bottom cable terminal

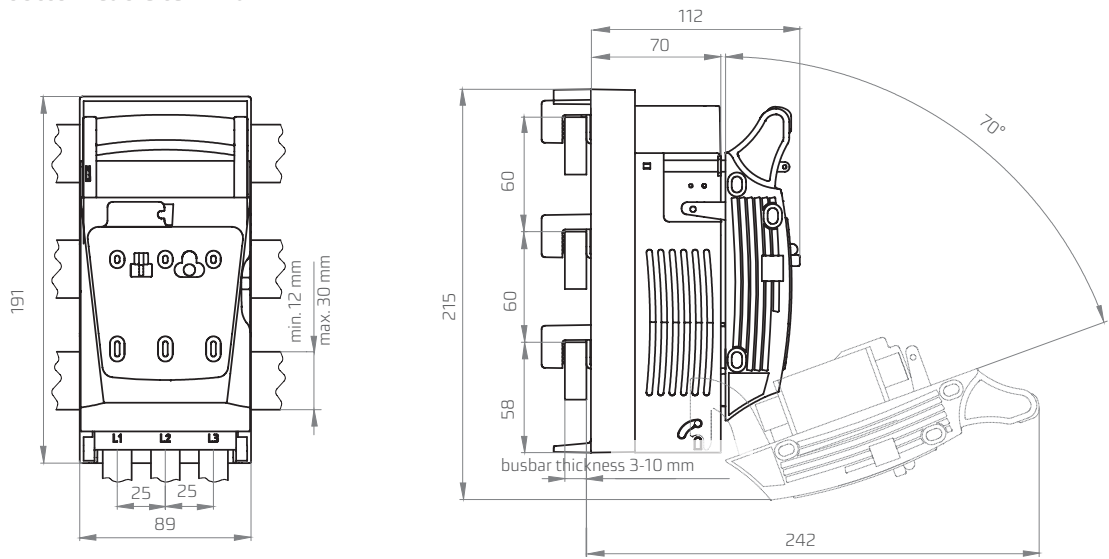

RBP 000 pro

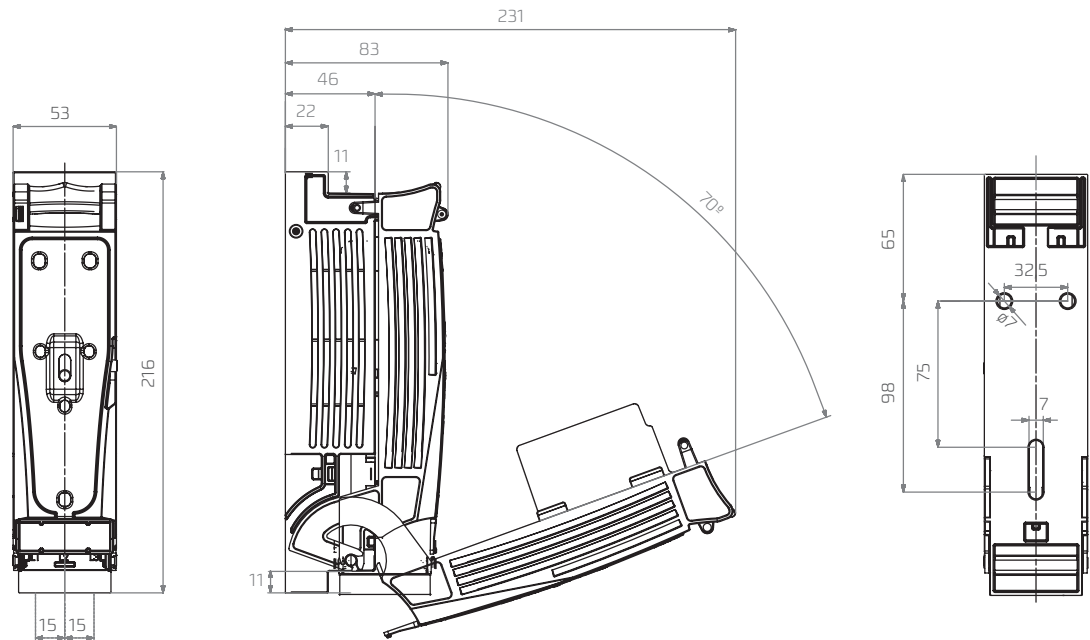

RBP 000 pro-S

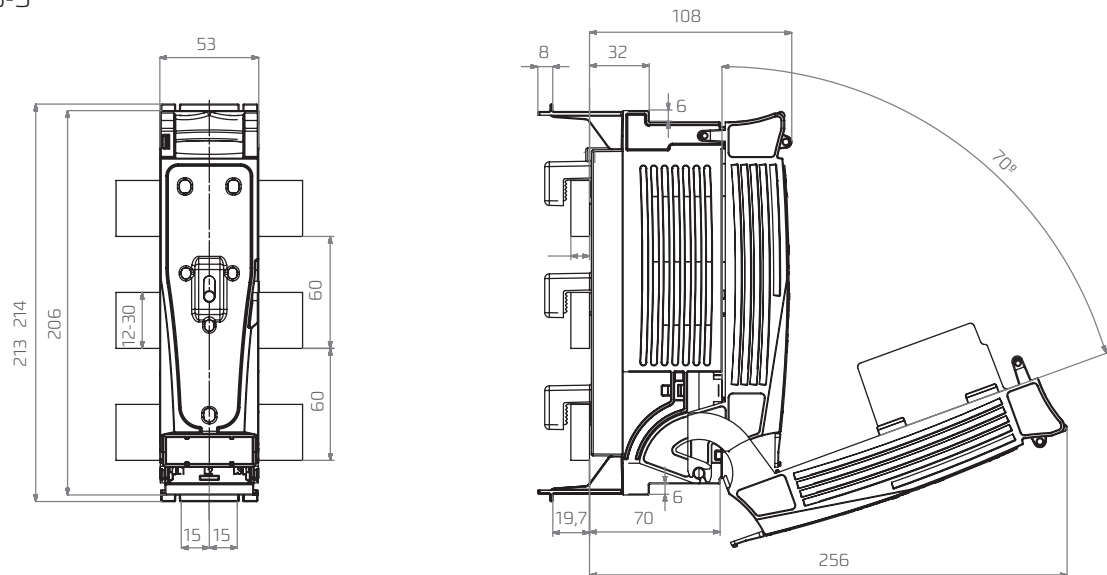

RBK 00 / RBK 00 pro

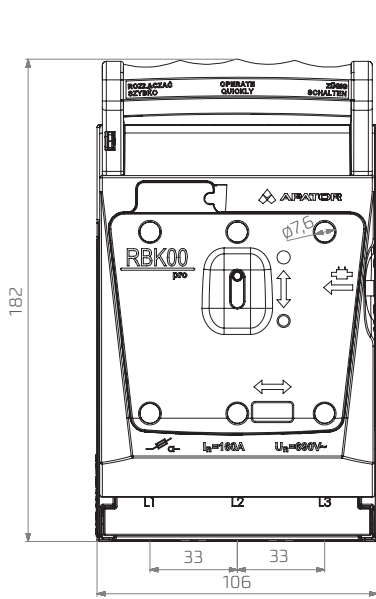

*122.5 mm for M screw terminal (for busbar and lug terminal)

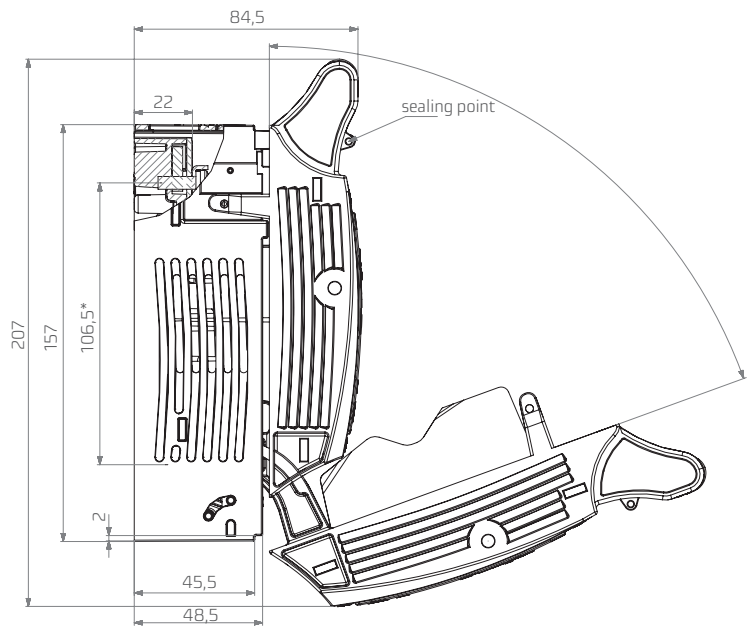

RBK 00-W / RBK 00 pro-W,

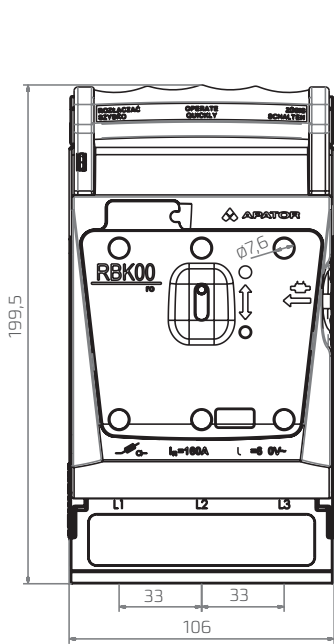

*122.5 mm for M screw terminal (for busbar and lug terminal)

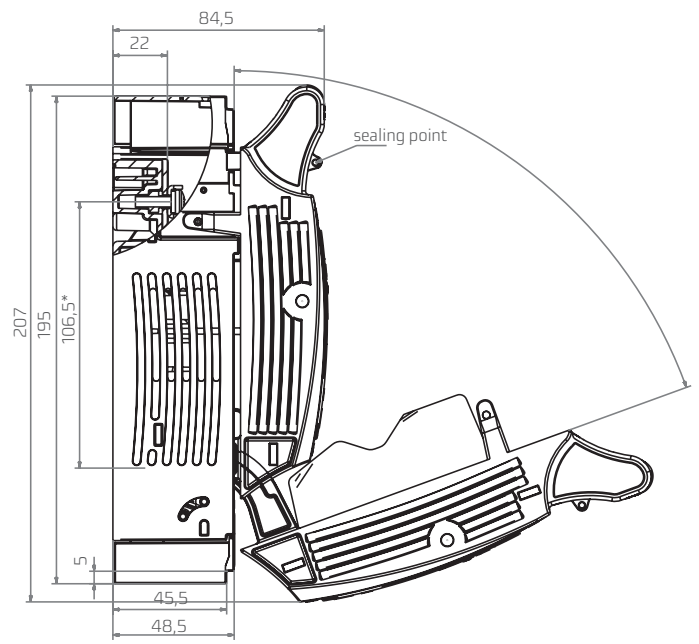

RBK DIMENSIONS

RBK 00 pro-S

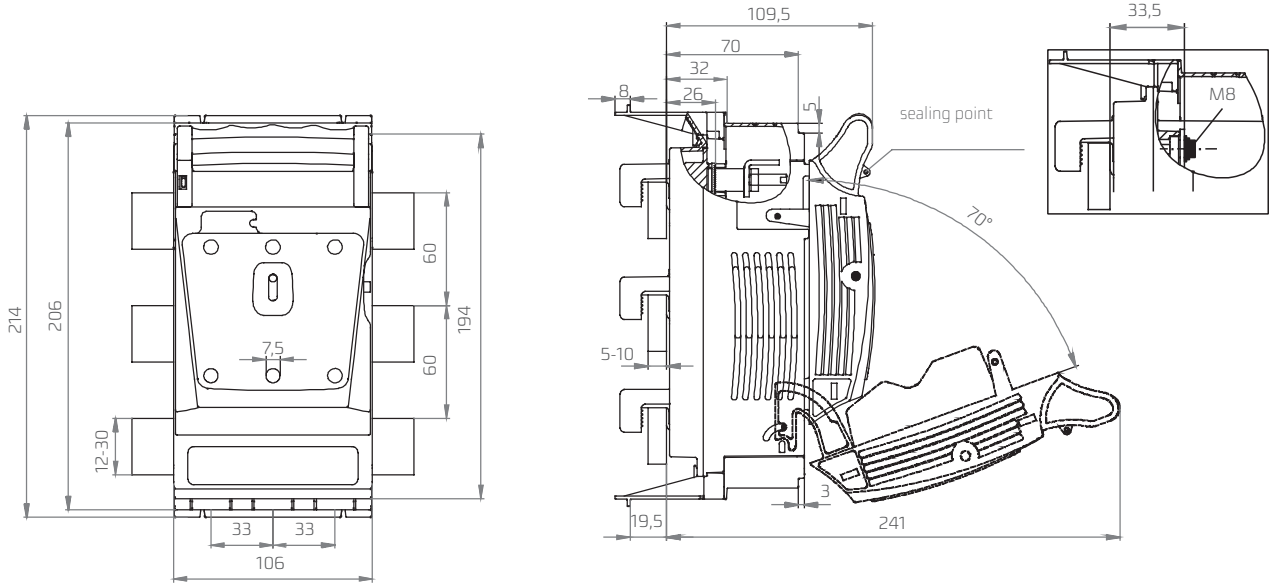

RBK 1, RBK 1 pro

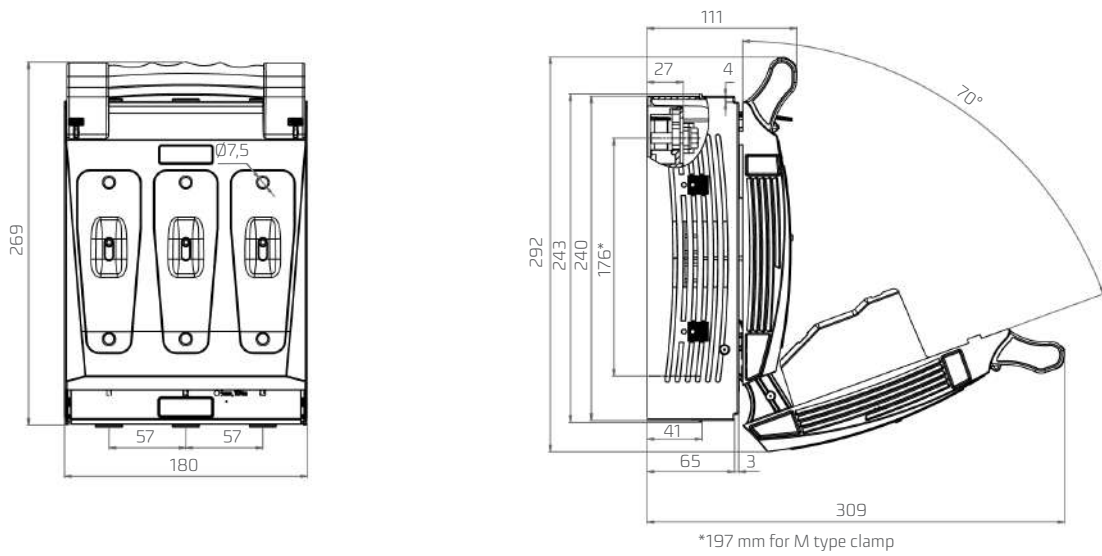

RBK 1 pro-V

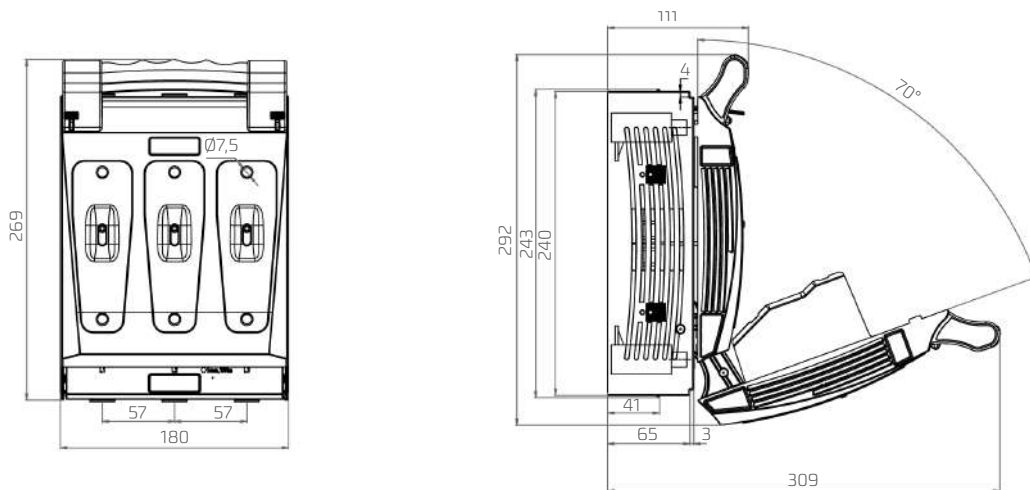

RBK 1 pro-SD, RBK 1 pro-SG

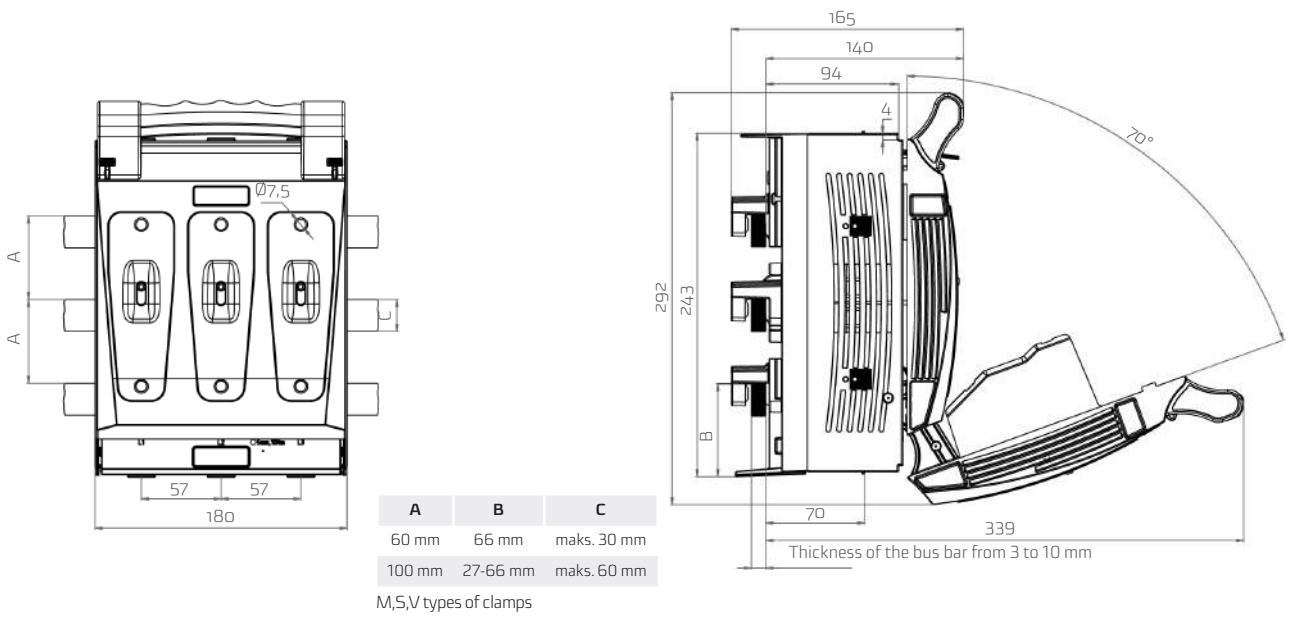

RBK 1 pro-O

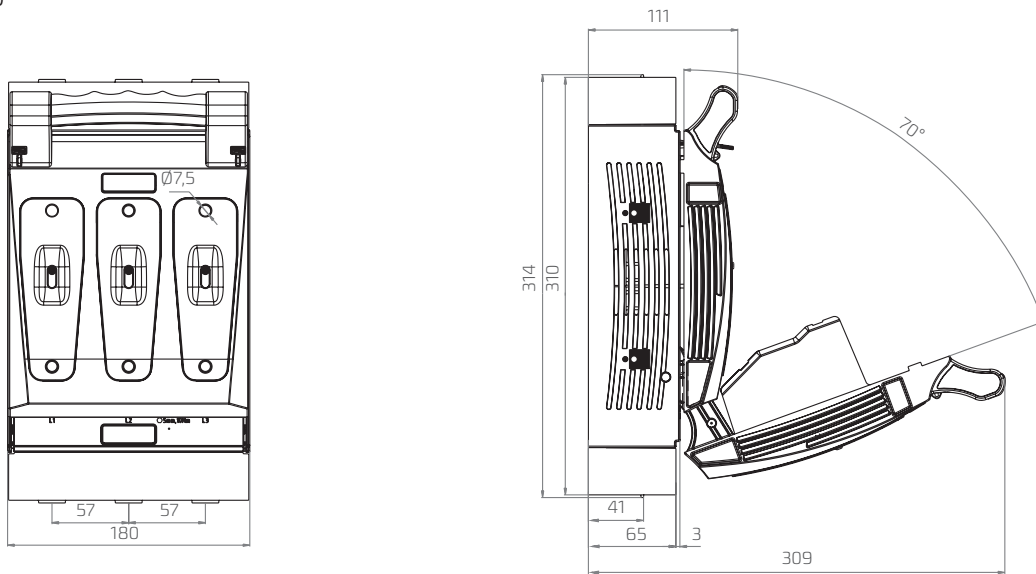

RBK 00 pro-V 120

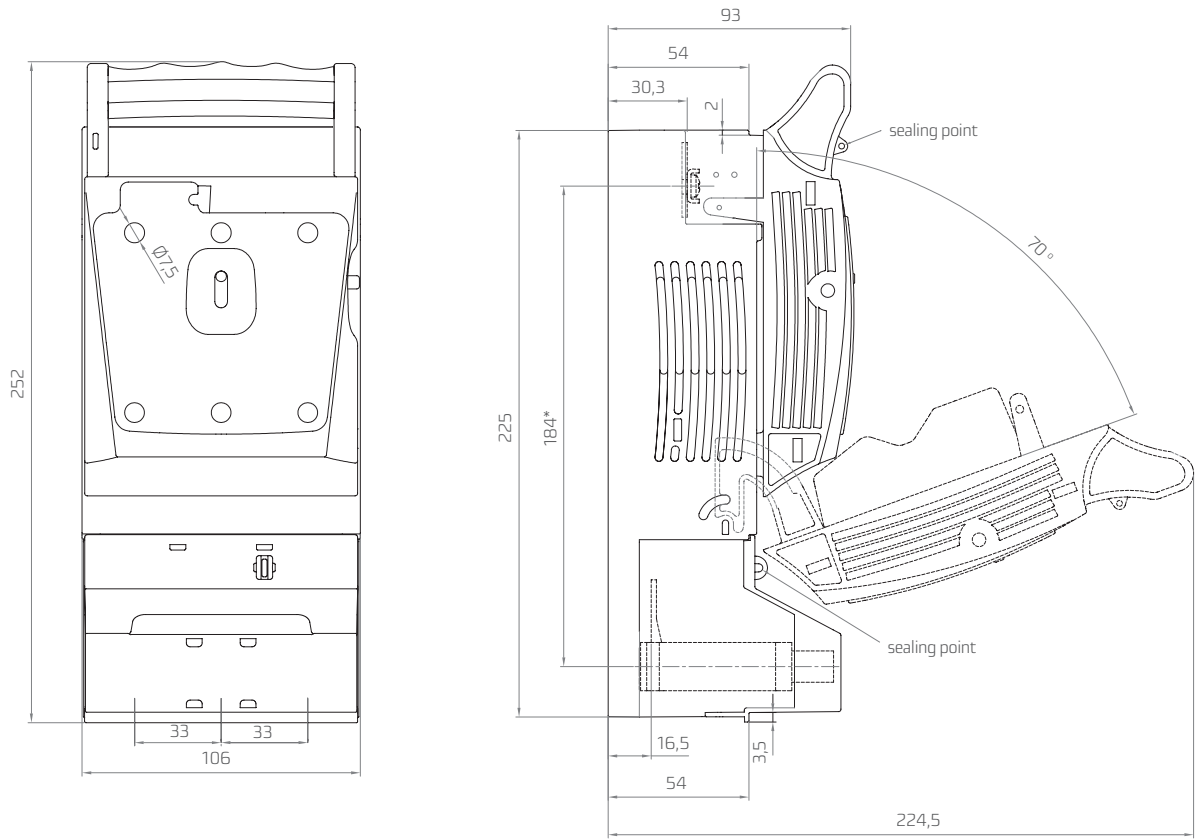

*197 mm for M screw terminal
(for busbar and lug terminal)

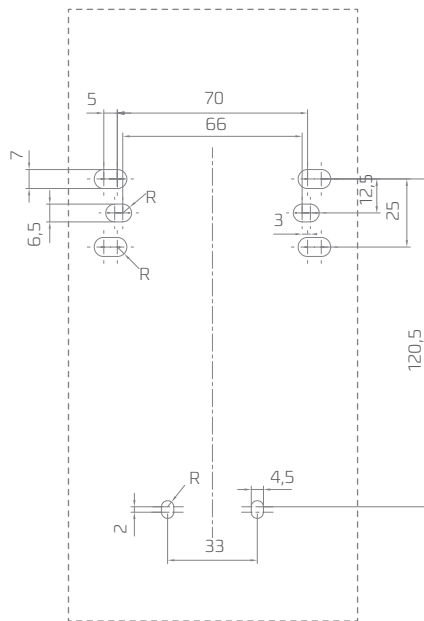

spacing of holes for installation
of RBK 00 pro-V120 on mounting plate

RBK 2 pro

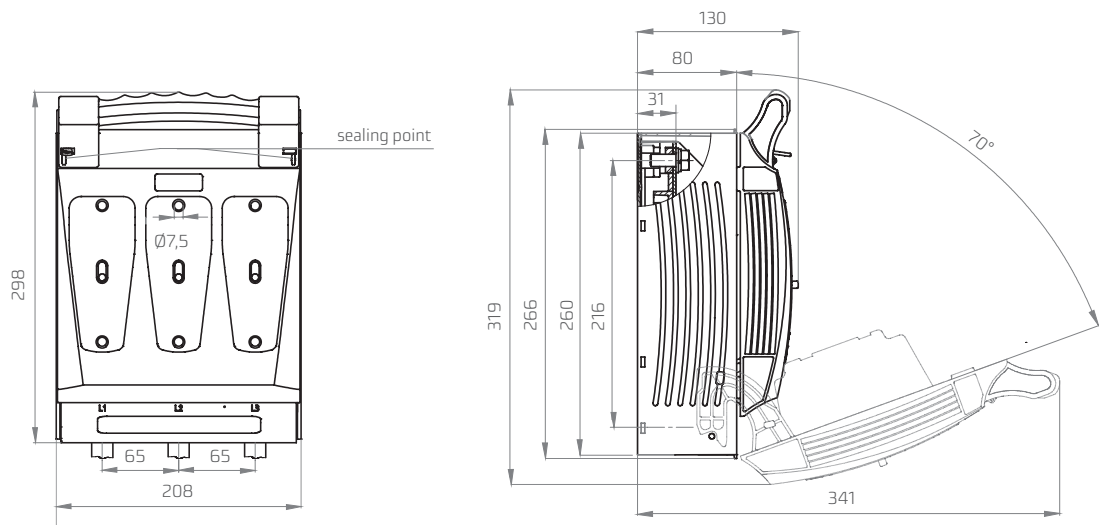

RBK 2 pro-V

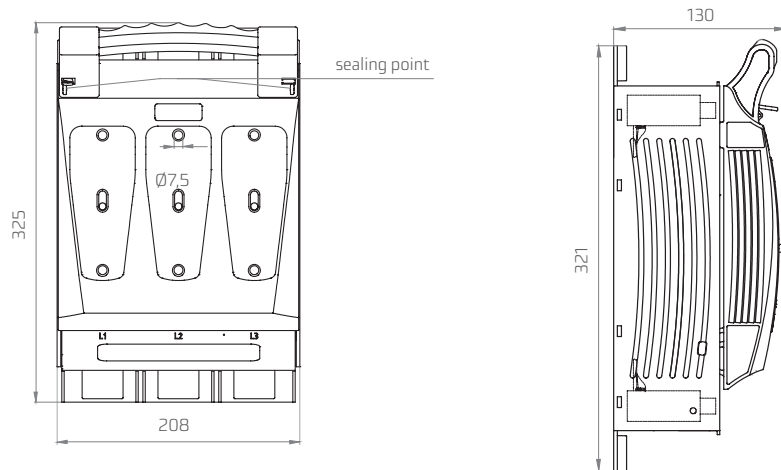

RBK 2 pro-2V

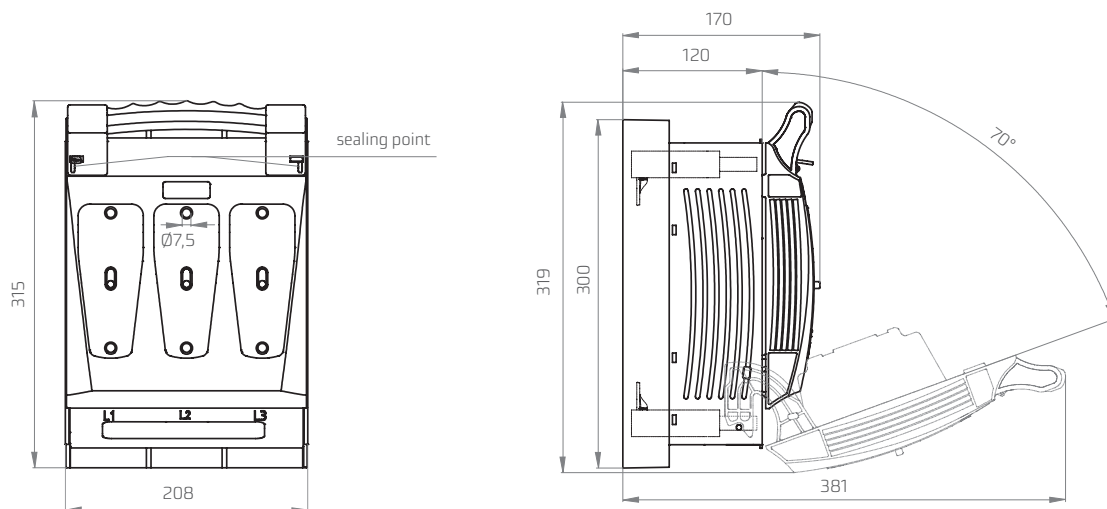

RBK DIMENSIONS

RBK 2 pro-SG / RBK 2 pro-SD

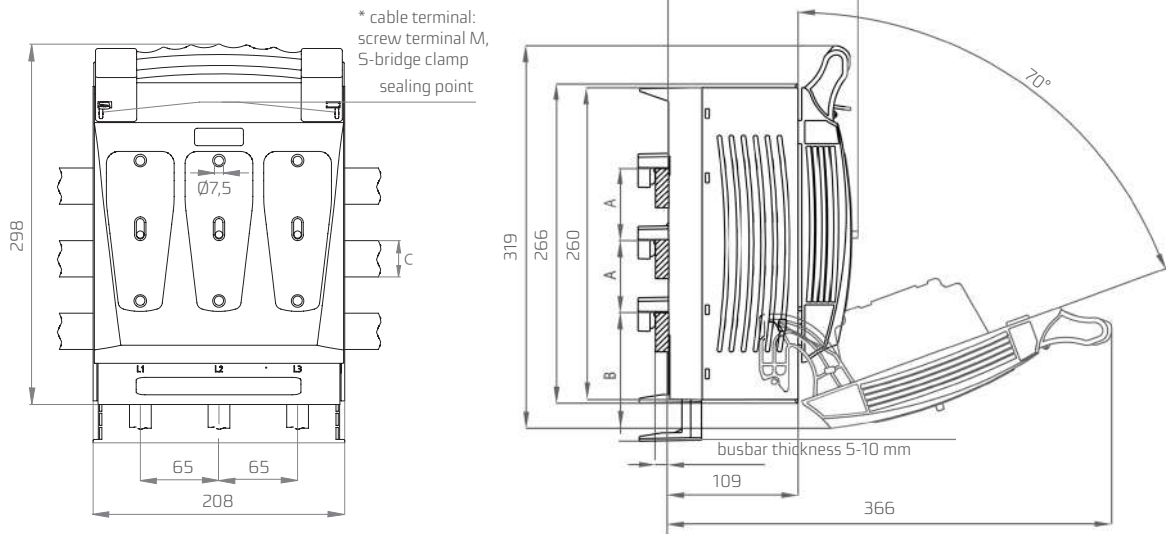

RBK 2 pro-SG-V / RBK 2 pro-SD-V

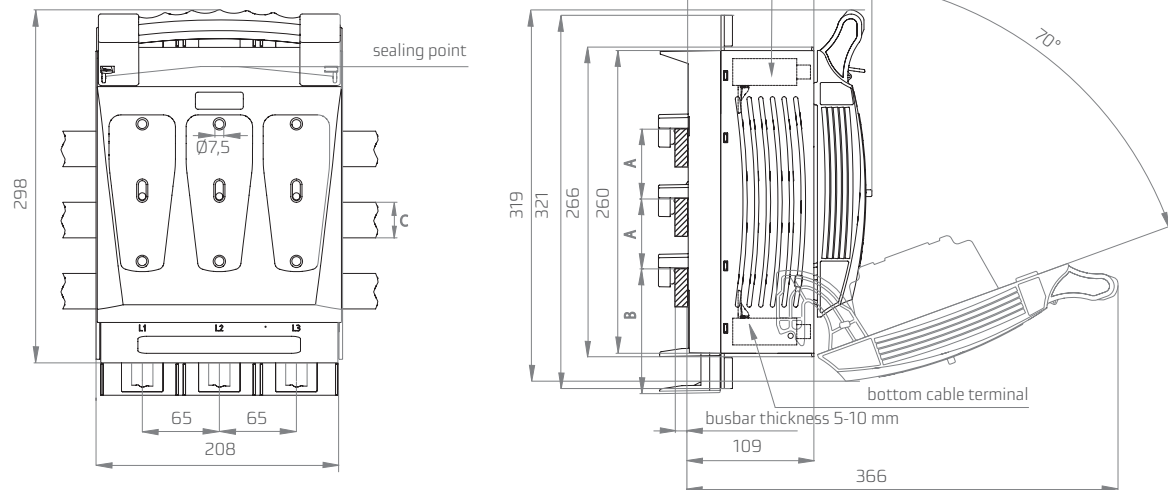

RBK 2 pro-SG-2V / RBK 2 pro-SD-2V

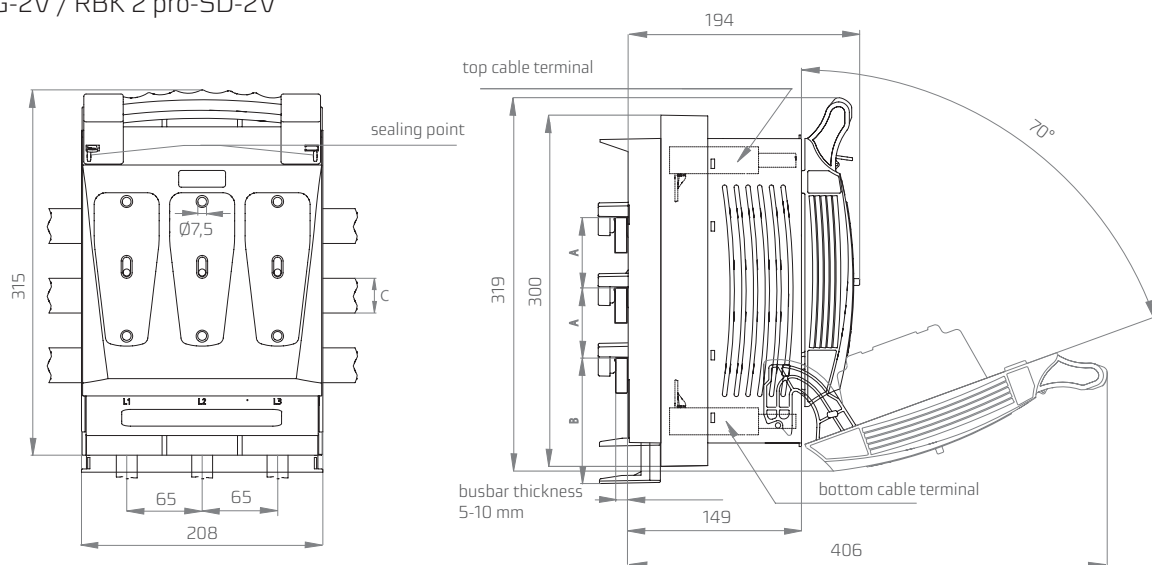

A	B	C
60 mm	75 mm	max. 30 mm
100 mm	35-67 mm	max. 60 mm

RBK 3 pro

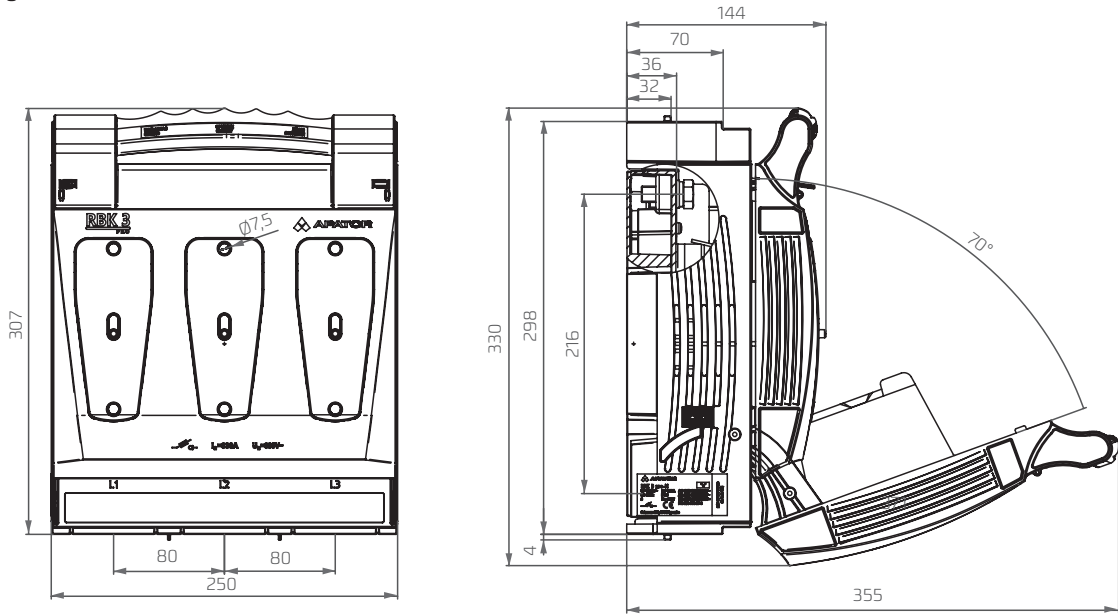

RBK 3 pro-5

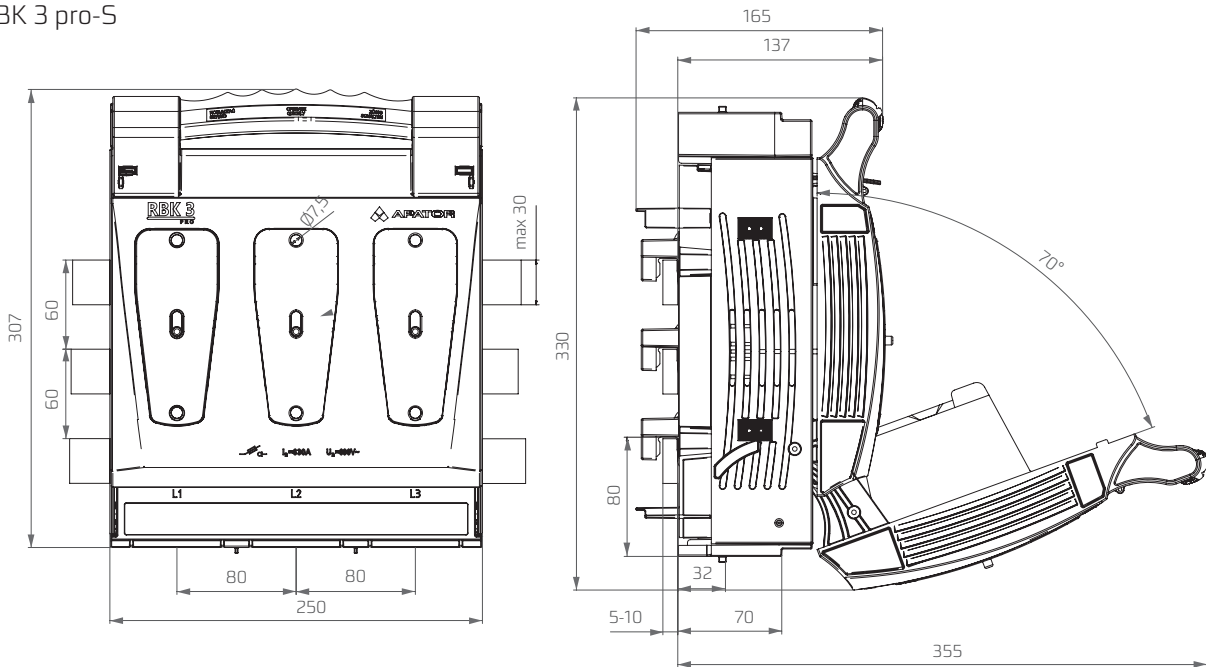

RBK 3 pro M-2xVD

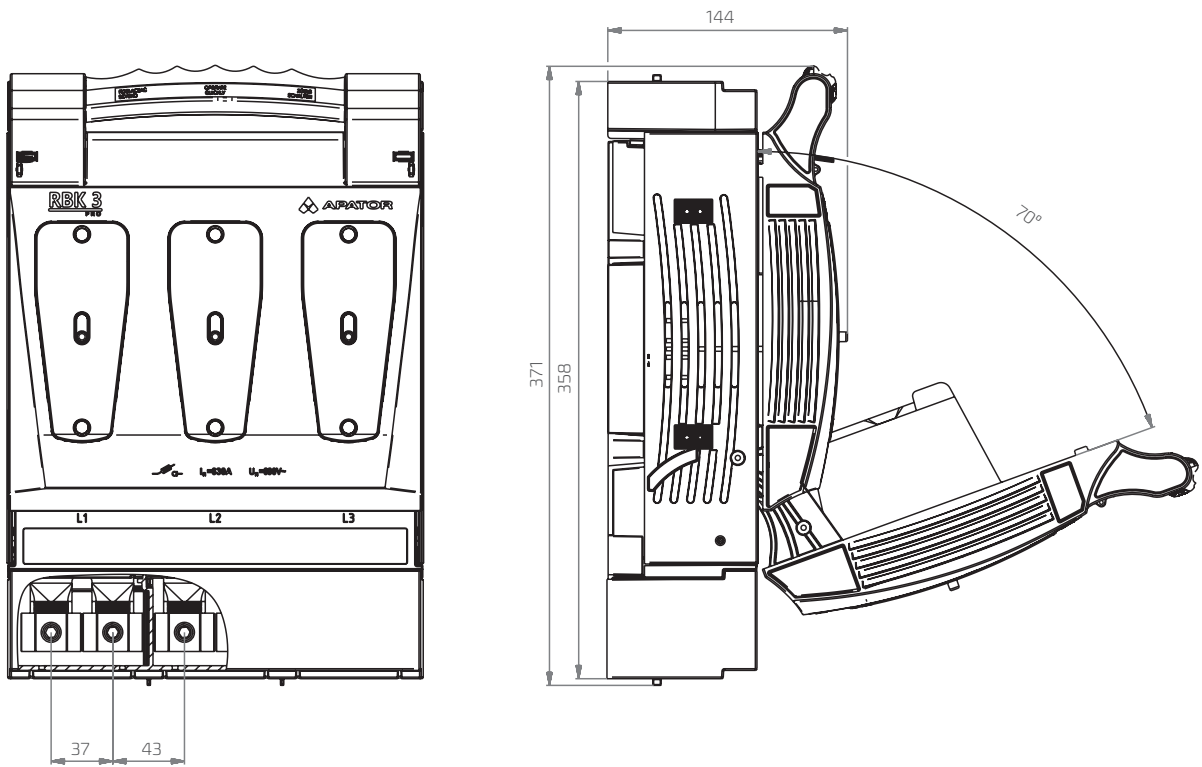

RBK 00-X

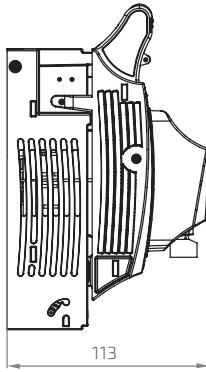

RBK 1-X

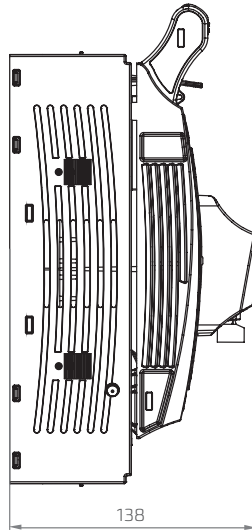

RBK 2-X

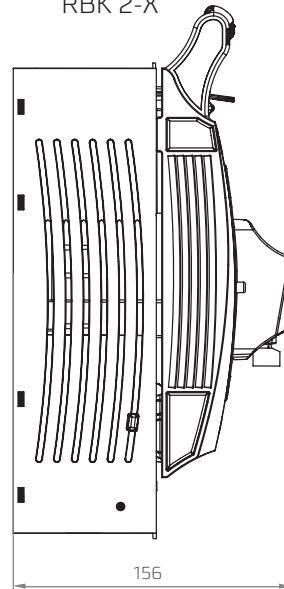

Terminal adapters:

RBK 00

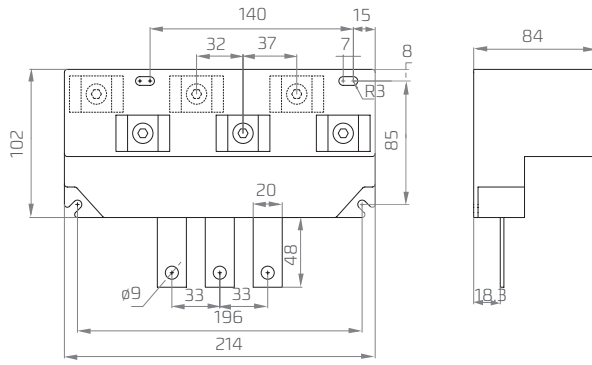

RBK 1

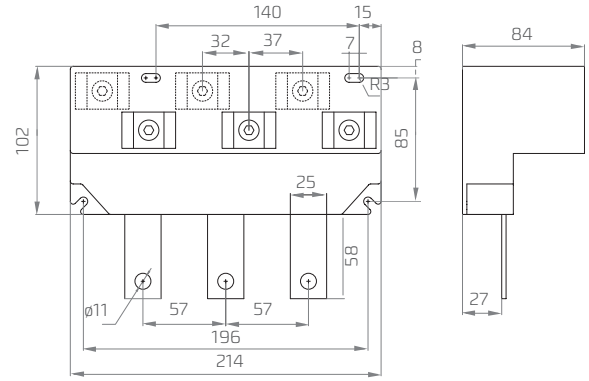

RBK 2

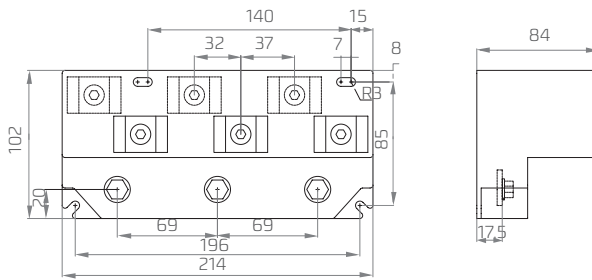

Table 100. RBP 000 pro - accessories

Description	Size	Article No.	Picture
Auxiliary contacts (microswitch) AC-15 U_e 230 V~ I_e 2,5 A DC-13 U_e 230 V~ I_e 0,3 A	000	1115296311T	
Microswitch shroud 1115296311T	000	51-946806-001	



RBK 000

Table 101. RBK 000 pro - accessories















Description	Size	Article No.	Picture
Feeding bridge 2 x RBK 000, 35 mm ²	000	1119510055T	
Feeding bridge 3 x RBK 000, 35 mm ²	000	1119510056T	
Feeding bridge 4 x RBK 000, 35 mm ²	000	1119510057T	
Feeding bridge 5 x RBK 000, 35 mm ²	000	1119510058T	
Feeding bridge 2 x RBK 000, 50 mm ²	000	1119510059T	
Feeding bridge 3 x RBK 000, 50 mm ²	000	1119510060T	
Feeding bridge 4 x RBK 000, 50 mm ²	000	1119510061T	
Feeding bridge 5 x RBK 000, 50 mm ²	000	1119510062T	
Feeding bridge RBK 000 25-95 mm ² (1 set - 3 pcs.) for connection of conductor of cross-section 25-70 mm ²  25-95 mm ² 	000	1119510071T	
Auxiliary contacts (microswitch) AC-15 U_e 230 V~ I_e 2,5 A DC-13 U_e 230 V~ I_e 0,3 A	000	1115296311T	
Microswitch shroud 1115296311T	000	51-000148-001	
Additional terminal shroud „O” extends shroud length of 25 mm	000	51-930160-011	

Table 102. RBK 00, RBK 00 pro - accessories

Description	Size	Article No.	Picture
Feeding bridge 2 x RBK 00, 35 mm ²	00	1119510063T	
Feeding bridge 3 x RBK 00, 35 mm ²	00	1119510064T	
Feeding bridge 4 x RBK 00, 35 mm ²	00	1119510065T	
Feeding bridge 5 x RBK 00, 35 mm ²	00	1119510066T	
Feeding bridge 2 x RBK 00, 50 mm ²	00	1119510067T	
Feeding bridge 3 x RBK 00, 50 mm ²	00	1119510068T	
Feeding bridge 4 x RBK 00, 50 mm ²	00	1119510069T	
Feeding bridge 5 x RBK 00, 50 mm ²	00	1119510070T	
Feeding bridge clamp 00 25-95 mm ² (1 set - 3 pcs.) for connection of conductor of cross-section	00	1119510072T	
25-70 mm ² 25-95 mm ²			
Clamp for RBK 00 2x25 mm ² 1x16 mm ²	00	1119510073T	
Clamp for RBK 00 4x10 mm ²	00	1119510074T	



RBK 00

Description	Size	Article No.	Picture
Auxiliary contacts (microswitch) AC-15 U_e 230 V~ I_e 2,5 A DC-13 U_e 230 V~ I_e 0,3 A	00	1115296311T	
Microswitch shroud 1115296311T	00	51-000148-001	
Additional terminal shroud extends shroud length of 25 mm	00	51-930499-011	
Terminal adapter + 3 x V-clamp + terminal shroud	RBK 00	1119510048T	
	RBK 00 W	1119510043T	

Table 103. RBK 1, RBK 1 pro, RBK 2 pro, RBK 3 pro - accessories

Description	Size	Article No.	Picture
Auxiliary contacts (microswitch) AC-15 U_e 230 V~ I_e = 2,5 A DC-13 U_e 230 V~ I_e = 0,3 A	RBK 1 RBK 1 pro RBK 2 RBK 3	1115296316	
Additional terminal shroud extends shroud length of 35 mm	RBK 1 pro-0	51-823278-011	
Additional terminal shroud „O” extends shroud length of 60 mm	RBK 2-0	51-822405-011	
Additional terminal shroud extends shroud length of 60 mm	RBK 3-0	51-823329-011	
Terminal adapter RBK 1 + 3 x V-clamp + terminal shroud	RBK 1	1119510038T	
Terminal adapter RBK 2 + 3 x V-clamp + terminal shroud	RBK 2	1119510047T	

Table 104. RBK 000, RBK 00 feeding bridges technical data

Materials	Cu busbar Insulating parts, pressed PC/ABS RAL7035 Cover, injection molded PC/ABS RAL7035 Shroud, injection molded PC/ABS RAL7035
Temperature range	>80 °C UL94V0
Glow wire flammability index	pressed PC/ABS 960 °C / 3.2 mm 850 °C / 1 mm injection molded PC/ABS 960 °C / 1 mm
Insulation properties	Overvoltage category III/Pollution degree rating II
CTI	pressed PC/ABS 600 V injection molded PC/ABS 250 V
Short-circuit strength	25 kA/0.1 s
Dielectric strength	>32 kV / mm
Rated impulse withstand voltage 35 mm²/ 50 mm²	>6.5 kV / >8.5 kV
Minimal insulating distance in air 35 mm²/ 50 mm²	>6 mm / >8 mm
Minimal creepage distance 35 mm²/ 50 mm²	>8.5 mm / >9 mm
Rated switching voltage	690 V

Feeding bridge length	max. 1000 mm	max. 300 mm	max. 1000 mm	max. 300 mm
Cross-section	35 mm ²	35 mm ²	50 mm ²	50 mm ²
Power supply connection point at the end or at the beginning of feeding bridge				
Maximum I _s current / phase	125 A	200 A	160 A	250 A
Feeding conductors cross-section	35 mm ²	70 mm ²	50 mm ²	95 mm ²
Other points of connection of power supply to the feeding bridge				
Maximum feeding current I _e	160 A	250 A	160 A	250 A
Feeding conductors cross-section	70 mm ²	95 mm ²	70 mm ²	95 mm ²

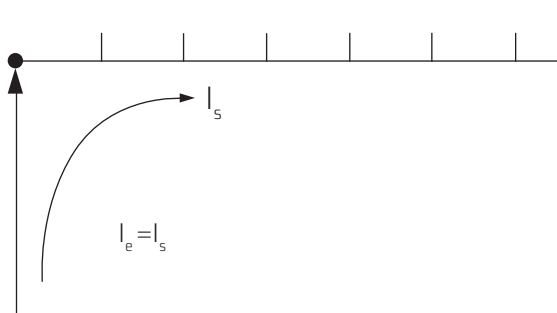

Power supply connection point at the end or at the beginning of bridge

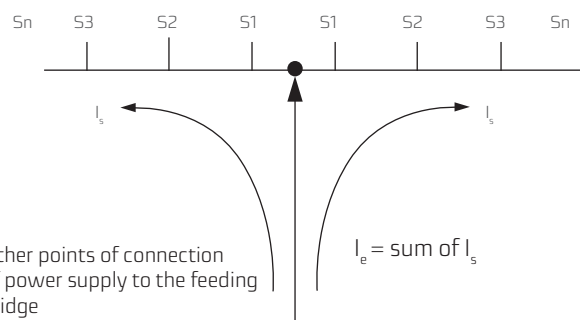

Other points of connection of power supply to the feeding bridge

In case of connection of power supply in the middle of feeding bridge sum of output currents S_1, \dots, S_n cannot be greater than corresponding maximum current I_s .

APPLICATION EXAMPLES

Fuse switch disconnectors **RBK 00** connected with feeding bridge, power supply cables connected to feeding bridge clamps

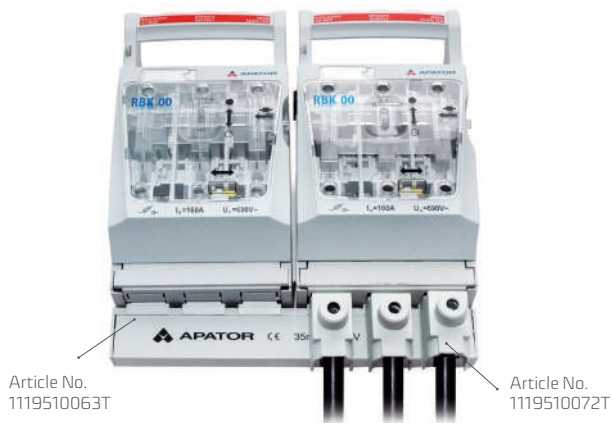

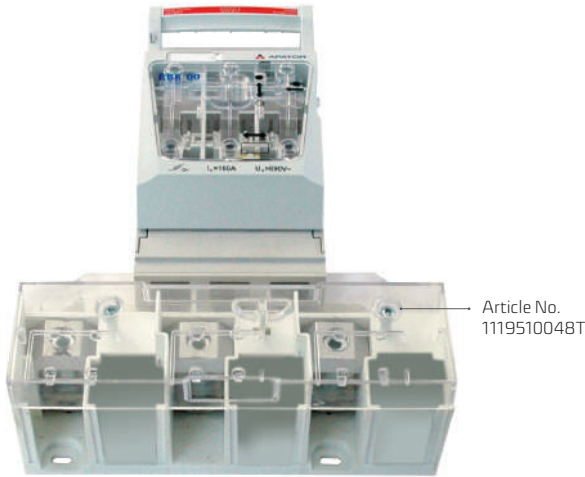

RBK 00-W with terminal adapter for connection of sector-shaped conductors with cross-section up to 240 mm²

35-185		35 - 240mm ²	
35 - 240 mm ²		35 - 300 mm ²	

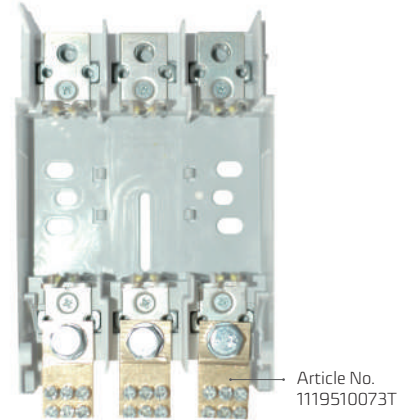

RBK 00-W with terminal clamp 1x16 mm², 2x25 mm² (view of fuse switch disconnecter without fuse-link cover and terminal shrouds)

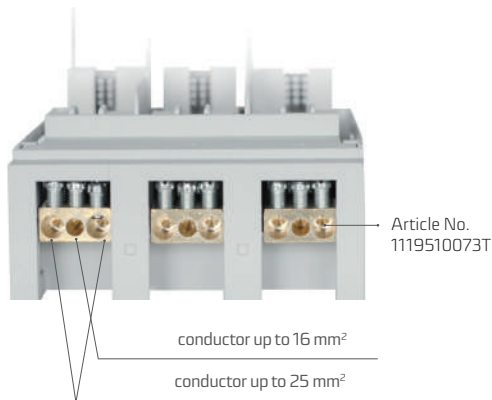

RBK 00-W with terminal clamp 1x16 mm², 2x25 mm² (view of fuse switch disconnecter without fuse-link cover)



RBK 00 for installation on mounting plate, version with additional terminal shrouds



RBK 000 for installation on mounting plate, version with additional terminal shrouds



RBK 1 for installation on mounting plate, version with additional terminal shrouds

Terminal adapter for RBK 00 i RBK 1



Covering of RBK fuse switch disconnectors (rear installation)

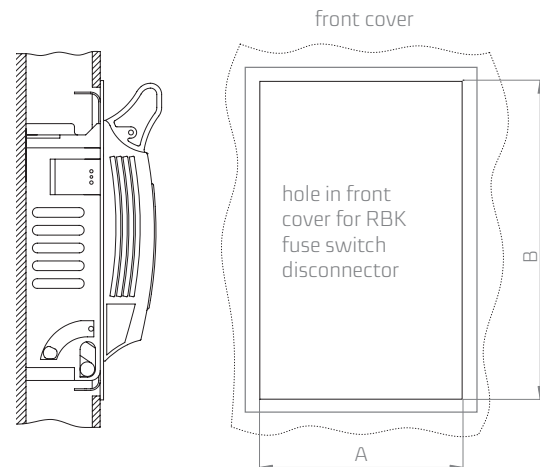
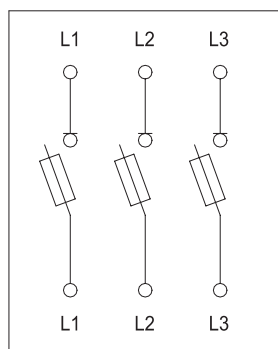

Table 105. Front cover dimensions

Type	A	B
RBK 000	91	156
RBK 000-S, RBK 000-W	91	195
RBK 00, RBK 00 pro, RBK 00 pro-S	108	154
RBK 00-W	108	184
RBK 1, RBK 1-S, RBK 1 pro	184	232
RBK 2, RBK 2-S	210	255
RBK 2-V, RBK 2-2V	210	255
RBK 3, RBK 3-S	258	316

Electrical diagrams (RBK 1-S, RBK 3-S - possible bottom cable terminal connection)



RBK 000
RBK 00
RBK 00 pro
RBK 1
RBK 2
RBK 3
RBK 1 pro
RBK 2 pro
RBK 3 pro

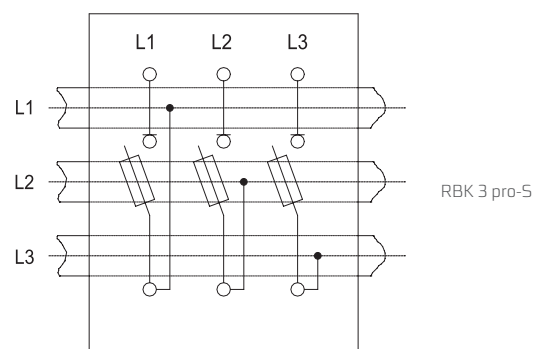

RBK 3 pro-S

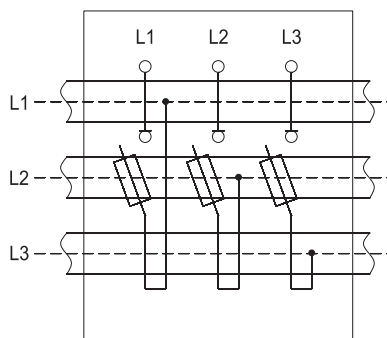

RBK 000-SG
RBK 00 pro-SG
RBK 1 pro-SG
RBK 2 pro-SG

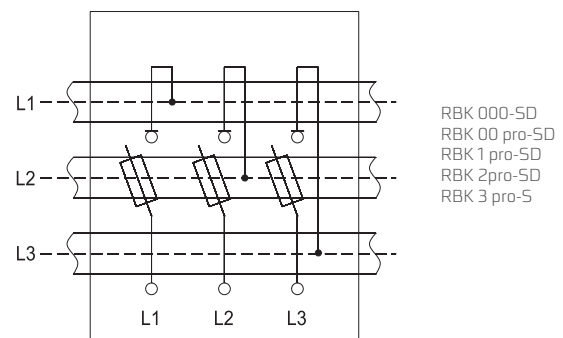

RBK 000-SD
RBK 00 pro-SD
RBK 1 pro-SD
RBK 2 pro-SD
RBK 3 pro-S

Universal earthing device for RBK 000, 00, 1, 2, 3

Article No 1115281041T

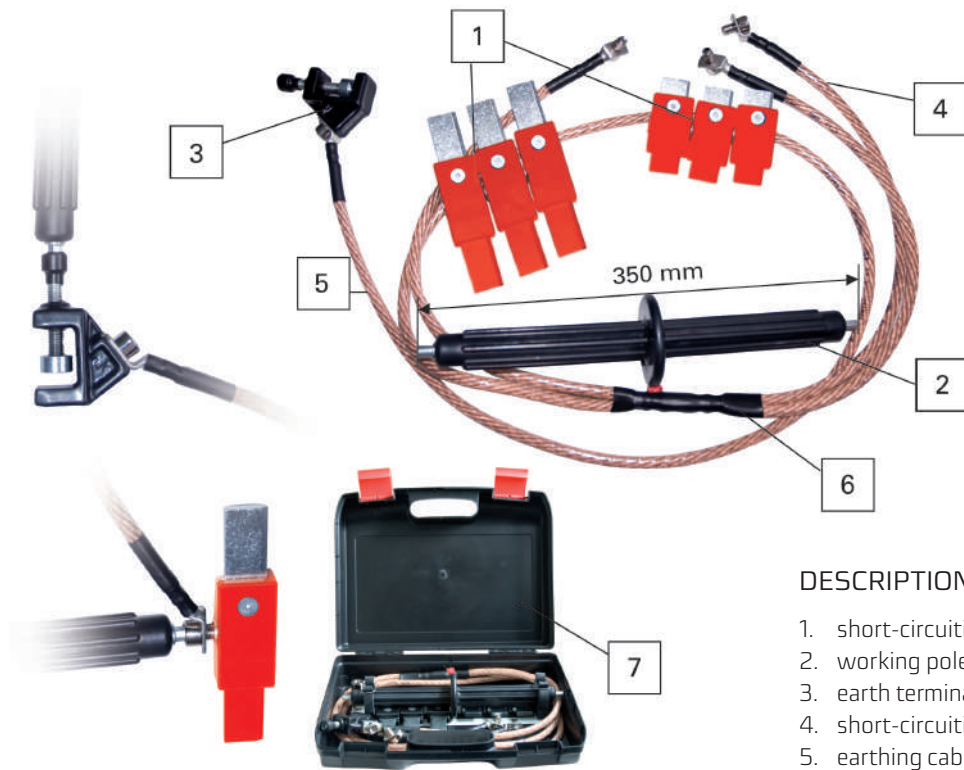

DESCRIPTION

1. short-circuiting links
2. working pole
3. earth terminal
4. short-circuiting cable
5. earthing cable
6. cable connection point
7. case

Example of the order of RBK 2-SD-V-100

Fuse switch disconnector	160 A	RBK 000, RBK 00, RBK 00 pro	
	250 A	RBK 1, RBK 1 pro	
	400 A	RBK 2 pro	RBK 2 pro
	630 A	RBK 3 pro	
Terminal clamps	S		S
	D	bottom	D
For installation on to busbar system	G	top	
	V	V-clamp	V
Cable terminal	2V	double V-clamp	
	M	screw terminal	
	S	S-bridge clamps	
Busbar system	60 mm	60	
	100 mm	100	100



PBD

fuse bases

- designed for distribution of electricity and protection of electrical equipment against short-circuits and overloads with industrial fuse links

CONSTRUCTION & APPLICATIONS

PBD fuse base consist of flame retardant thermoplastic base with spring-loaded contacts designed to be engaged with the blade contacts of NH fuse link. Contacts of sizes 00, 1, 2 are tin plated, contacts of size 3 are silver plated. On request contacts of sizes 00, 1, 2 are plated with silver.

PBD fuse-bases are designed for installation indoors, in environment free of dust, aggressive or explosive gases:

- junction boxes,
- supply points,
- distribution boards,
- capacitor bank protection.

OPERATING CONDITIONS

- altitude up to 2000 meters above sea level,
- ambient temperature from -25°C to +55°C,
- for outdoors installation PBD fuse basess should be mounted in cabinets with protection degree IP34 or higher.

CONFORMITY WITH STANDARDS

IEC 60269-1, PN-HD 60269-2:2008, PN-EN 60269-1:2010

VERSIONS

PBD fuse bases are designed for fuse links size 00-3. There are following versions:

- size 00 - 160 A
 - with double side screw terminals for lug terminal or busbar - fuse base 1-pole PBD 00, fuse base 3-poles PBD 003 HH,
 - with V-terminal from one side and screw terminal from opposite side - fuse base 1-pole PBD 00-1V, fuse base 3-poles PBD 00 3-1V,
 - with both sides V-terminals - fuse base 1-pole PBD 00-2V, fuse base 3-poles PBD 00 3-VV,
 - the possibility of using fuse links size 00 and 000.
- size 1 – 250 A
 - with double side screw terminals for lug terminal or busbar - fuse base 1-pole PBD 1, fuse base 3-poles PBD 13,
 - with V-terminal from one side and screw terminal from opposite side - fuse base 1-pole PBD 1-1V, fuse base 3-poles PBD 13-1V,
 - with both sides V-terminals - fuse base 1-pole PBD 1-2V, fuse base 3-poles PBD 13-2V.
- size 2 – 400 A
 - with double side screw terminals for lug terminal - fuse base PBD 2,
 - with V-terminal from one side and screw terminal from opposite side - fuse base PBD 2-1V,
 - with both sides V-terminals - fuse base PBD 2-2V.
- size 3 – 630 A
 - with double side screw terminals for lug terminal - fuse base PBD 3.

V-terminals with V-clamps enable connection of circular or sector-shaped conductors.



PBD 1-2V

PBD 2-1V

PBD 3

PBD 003 HH

PBD 003 VV



Table 106. PBD fuse bases for WTNH fuse links

Article	Size	Rated current	Rated shortcircuit withstand current	Cable terminal	Rated power dissipation	Max crosssection of cable conductors	Weight [g]	Article No.
PBD 00	00	160 A	25 kA	screw terminals 	12 W	70 mm ²	90	1115281070T
PBD00VV	00	160 A	25 kA	V-terminals 	12 W	120 mm ²	90	1115281071T
PBD 00-1V	00	160 A	25 kA	screw terminal, V-terminal  	12 W	70 mm ² 120 mm ²	90	1115281073T
PBD 003 HH	00	160 A	25 kA	screw terminals 	3 x 12 W	50 mm ²	500	1115 2810 42T
PBD 003 + shroud	00	160 A	25 kA	screw terminals 	3 x 12 W	50 mm ²	500	1115 2810 72T
PBD 003 1-V	00	160 A	25 kA	Screw terminal, V-terminal  	3 x 12 W	50 mm ²	500	1115 2810 80T
PBD 003 VV	00	160 A	25 kA	V-terminals 	3 x 12 W	120 mm ²	400	1115 2810 43T
PBD 1	1	250 A	40 kA	screw terminals 	32 W	120 mm ²	370	63-820991-011
PBD 1-1V	1	250 A	40 kA	screw terminal, V-terminal  	32 W	120 mm ²	370	63-820991-021
PBD 1-2V	1	250 A	40 kA	V-terminals 	32 W	120 mm ²	370	63-820991-031
PBD 13	1	250 A	40 kA	screw terminals 	3 x 32 W	120 mm ²	1140	63-820995-011
PBD 13-1V	1	250 A	40 kA	screw terminal, V-terminal  	3 x 32 W	120 mm ²	1120	63-820995-021
PBD 13-2V	1	250 A	40 kA	V-terminals 	3 x 32 W	120 mm ²	1140	63-820995-031
PBD 2	2	400 A	50 kA	screw terminals 	45 W	240 mm ²	520	63-820992-011
PBD 2-1V	2	400 A	50 kA	Screw terminal, V-terminal  	45 W	240 mm ²	520	63-820992-021
PBD 2-2V	2	400 A	50 kA	V-terminals 	45 W	240 mm ²	520	63-820992-031
PBD 3	3	630 A	65 kA	screw terminals 	60 W	240 mm ²	810	63-820998-011

PBD fuse bases are made of self extinguishing, fibre glass strenghtened polyester. Mechanical durability: 250 cycles.

Delivered with set of:

- screws for screw terminals insulation barriers
- for 3 - pole fuse bases e.g. PBD 003, PBD13

PBD fuse base size	Tightening torque (Nm)	
		
00 \ 003	10	20
1	32	30
2	32	30
3	56	30

DIMENSIONS OF PBD FUSE BASES

PBD fuse bases of size 00 - 1-pole

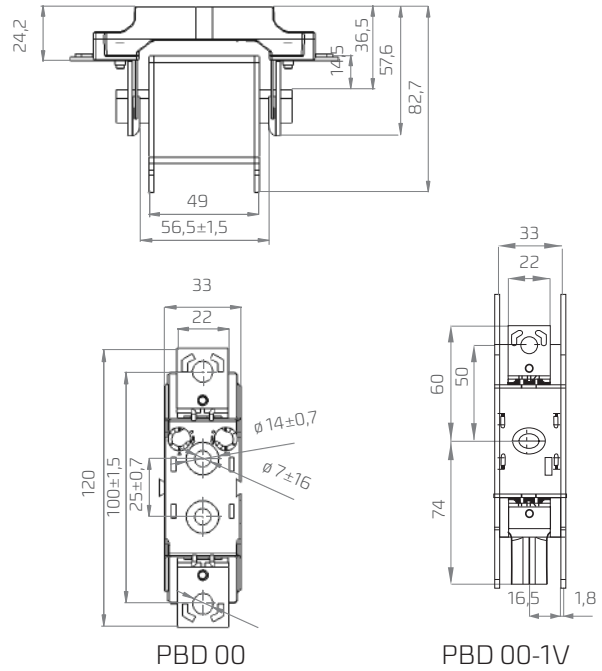
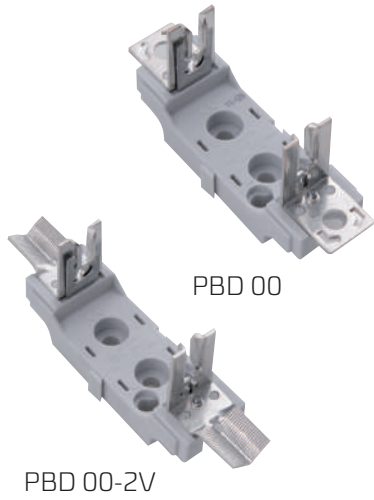

PBD fuse bases of size 00 - 3-pole

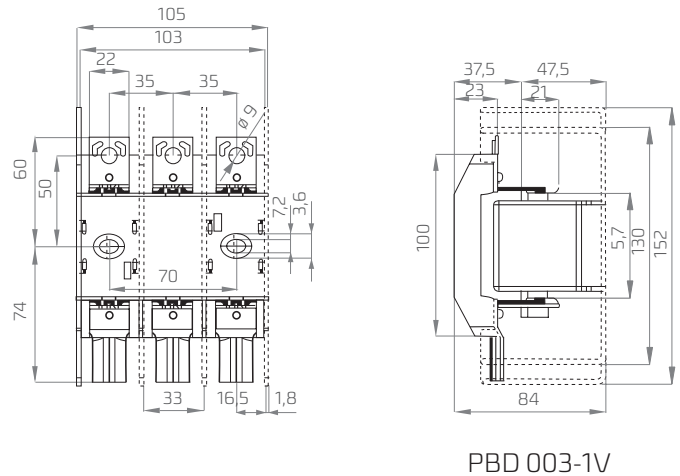
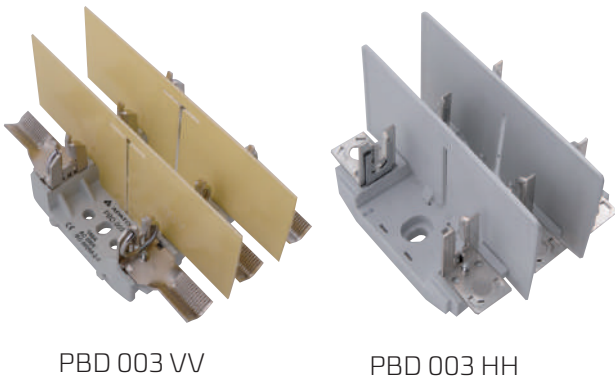

PBD fuse bases of size 1, 2, 3 - 1-pole

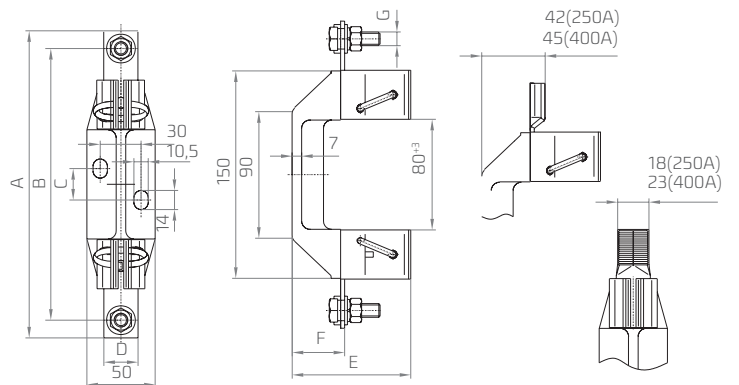
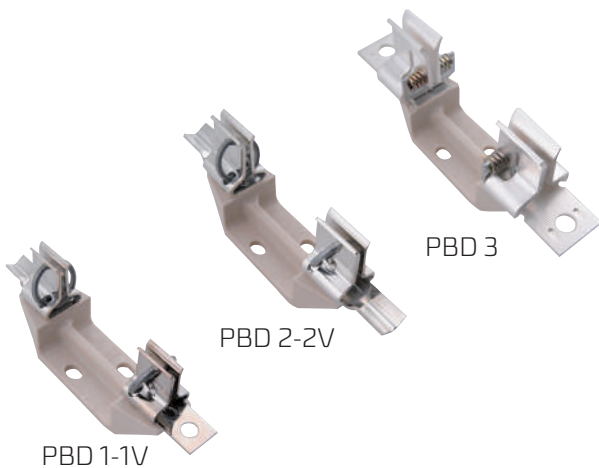

Article	Dimension [mm]						
	A	B	C	D	E	F	G
PBD 1	200	175	23	25	82	37	M10
PBD 1-1V	200	-	23	25	82	37	M10
PBD 1-2V	200	-	23	-	82	-	-
PBD 2	225	200	23	25	88	38	M10
PBD 2-1V	225	-	23	25	88	38	M10
PBD 2-2V	225	-	23	-	88	-	-
PBD 3	240	210	23	40	95	39	M12

PBD fuse bases of size 1, 2, 3 - 3-poles

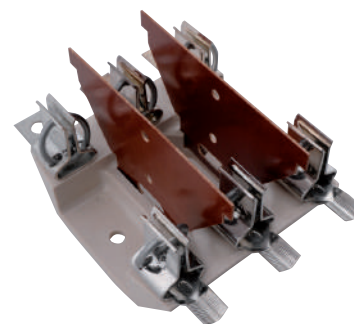
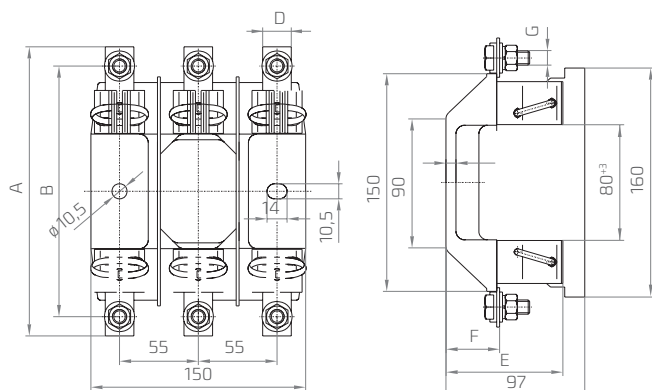

PBD 13-1V

Article	Dimension [mm]						
	A	B	C	D	E	F	G
PBD 13	200	175	-	-	82	37	M10
PBD 13-1V	-	-	-	-	82	37	M10
PBD 13-2V	-	-	-	-	82	-	-

PBD F fuse bases of size 1, 2, 3 - 1-pole and 3

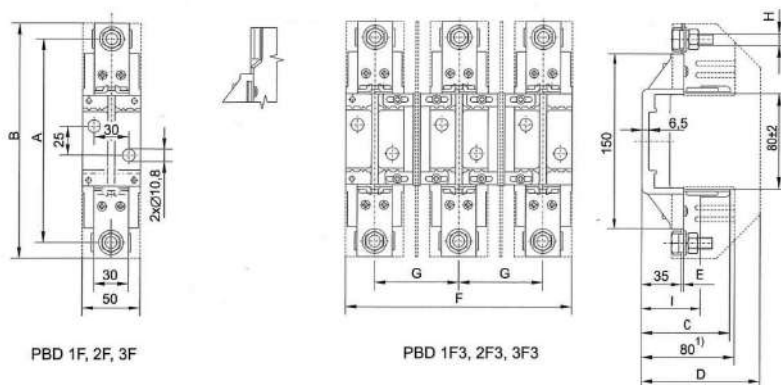

PBD 1F, 2F, 3F

PBD 1F3, 2F3, 3F3

Article No.	Article	Dimension [mm]							H	I
		A	B	C	D	E	F	G		
63-822369-011	PBD 1F	175	202	76	-	2	-	-	M10	48
63-822369-021	PBD 1F3				102		165	57,5		
63-822266-011	PBD 2F	200	230	84	-	2,5	-	-	M12	50,5
63-822266-021	PBD 2F3				110		180	65		
63-822268-011	PBD 3F	210	238	93	-	5	-	-	M12	50,5
63-822268-021	PBD 3F3				126		210	80		

ACCESORIES FOR PBD FUSE BASES

V-clamps, HS V-clamps (steel)

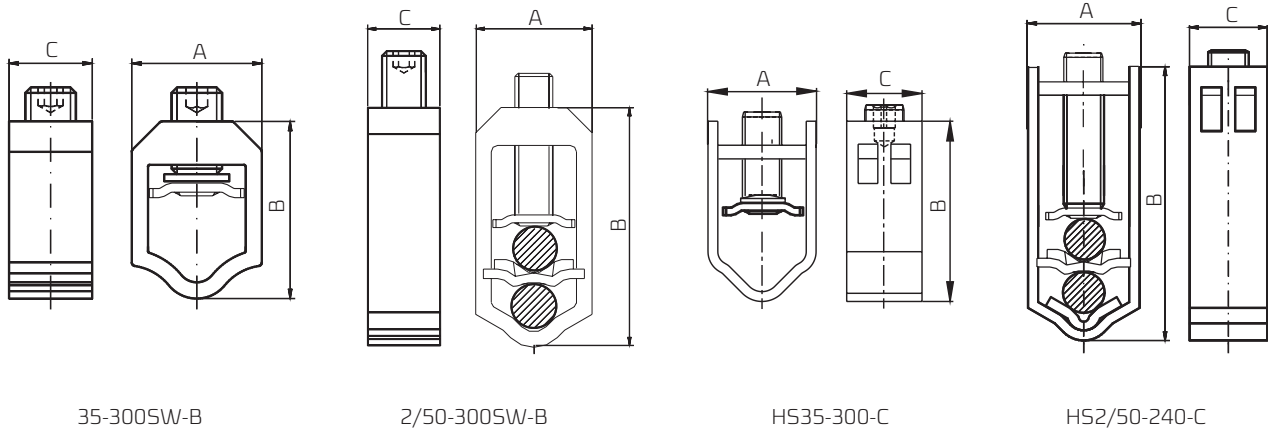



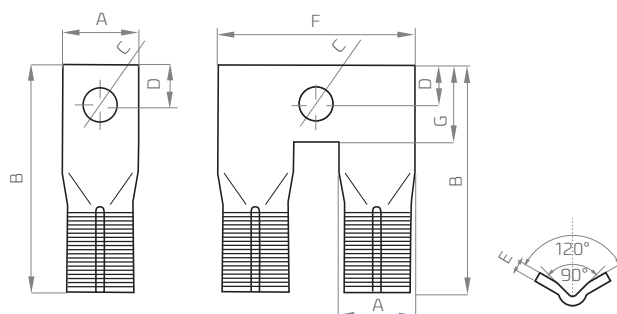

Table 107. V-clamps

	Article	Cross-section of cable conductor [mm ²]				Dimension [mm]			Tightening torque	Material	Weight [g]	Article No.
		re	se	rm	sm	width [A]	height [B]	depth [C]				
	25-150 SW	16÷95	25÷150	16÷95	25÷150	28	38	18,5	20 Nm	alu.	48	1119510091T
	HM10-120	10÷70	25÷120	10÷70	25÷95	28	38	18,5	15 Nm	steel	48	1119510077T
	2/25-120SW	16÷95	25÷120	16÷95	25÷120	27,5	58	18,5	30 Nm	alu.	87	1119510006T
	35-300SW-B	35÷240	35÷300	35÷185	35÷240	36	49	23	30 Nm	alu.	90	1119510081T
	2/50-300 SW-B	50÷240	50÷300	50÷185	50÷240	37	76	23	30 Nm	alu.	177	1119510082T
	HS 35-300-C	35÷240	35÷300	35÷185	35÷240	35	55	22	40 Nm	steel		1119510084T
	HS2/50-240-C	50÷240	50÷300	50÷185	50÷240	35	81	22	40 Nm	steel	228	1119510085T

Table 108. V-terminal lugs

	Article	Dimension [mm]							Material	Weight [g]	Article No.
		A	B	C	D	E	F	G			
	V-terminal lug VL120	20	65	10,5	10	3	–	–	Cu	32	1119510005T
	V-terminal lug VL240	25	75	13	11,5	5	–	–	Cu	75	1119510002T
	Double V-terminal lug C	25	75	10,7	12,5	3	65	25	Cu	107	1119510028T





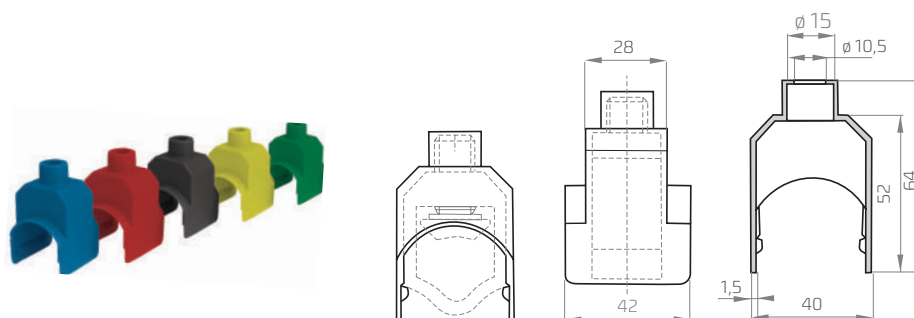

Shrouds for V-clamps

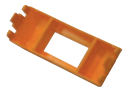

Shrouds for V-clamps 50-240SW i 70-300SW are available in colours: blue, red, black, yellow and green.

1119510018T-blue, 1119510019T-red, 1119510026T-black, 1119510044T-yellow, 1119510045T-green.

Table 109. PBD 00 accessories

Picture of Article	Description	Article No.
	Fuse-link shroud,	1115281078T
	Short shroud for contact and screw terminal	1115281076T
	Long shroud for contact and V-terminal clamp	1115281077T
	Shroud for 3-pole, size 00 fuse base with screw terminals	1115281079T
	Long insulation barrier for 3-pole fuse base with V-terminals	1115281074T

Examples of application

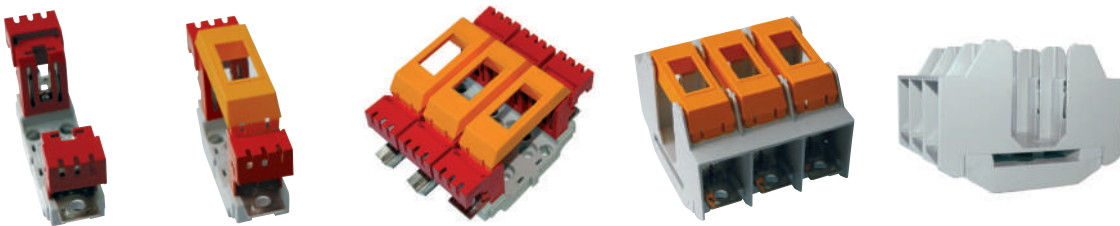

Universal earthing device UU00-3

Universal earthing device **UU00-3** is a portable device for temporary short-circuiting and earthing three phase AC low voltage circuit. Universal earthing device **UU00-3** is designed for earthing of solidly earthed neutral three phase systems or indirectly earthed neutral three phase systems. It is designed for mounting in place of fuse-links or for fixing to termination points with M10 thread.

Universal earthing device is designed for use with PBD fuse bases of all sizes (00 - 3).

Article No. : 1115281041T.

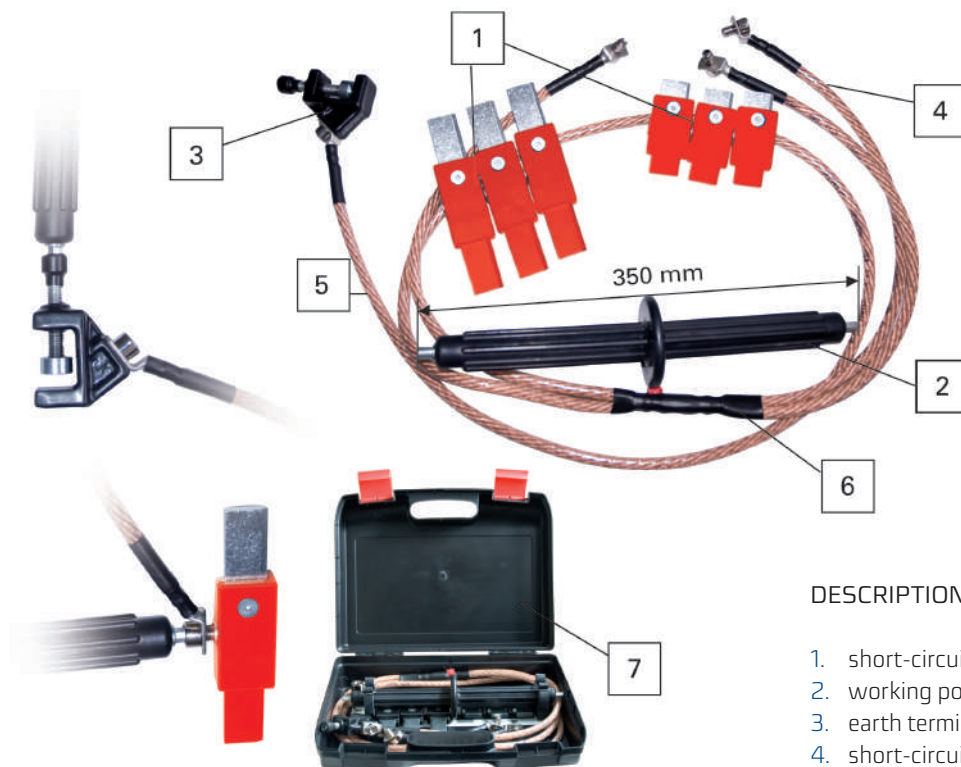

DESCRIPTION

- 1. short-circuiting links
- 2. working pole
- 3. earth terminal
- 4. short-circuiting cable
- 5. earthing cable
- 6. cable connection point
- 7. case

Universal replacement handle for WTNH fuse links

Sizes 00, 1, 2, 3 according to DIN 43.620 part 1

Replacement handle is designed for replacement and handling of NH fuse-links.

Fireproof insulating sleeve attached to replacement handle allows safe fuse link replacement and handling under live or load conditions.

Article	Article No.	Pcs.
Replacement handle for WTNH 00, 1, 2, 3 fuse links	1115282186T	10
Replacement handle with sleeve	1115282187T	10

Solid links

Dimensions according to PN/EN 60269/DIN 43 620. Standard version - silver plated copper.

Article	Article No.	Pcs.
Solid link size ZN 00 - 160A	1115282188T	3
Solid link size ZN 1 - 250A	1115282189T	3
Solid link size ZN 2 - 400A	1115282190T	3
Solid link size ZN 3 - 630A	1115282191T	3



Replacement handle with sleeve for WTNH fuse links



Replacement handle



Solid link



APASYS 60

60 mm busbar system

- APASYS 60 is a modular energy distribution system for currents up to 630 A
- the snap-on clip of all components provides great flexibility for the installation and expansion of solutions based on it

BUSBAR SUPPORTS for the 60 mm system

For busbars 12, 15, 20, 25 and 30 mm wide and 5 or 10 mm thick. Extremely versatile: the minimum number of components makes it possible to achieve a very large number of supporting set combinations.



APASYS 60

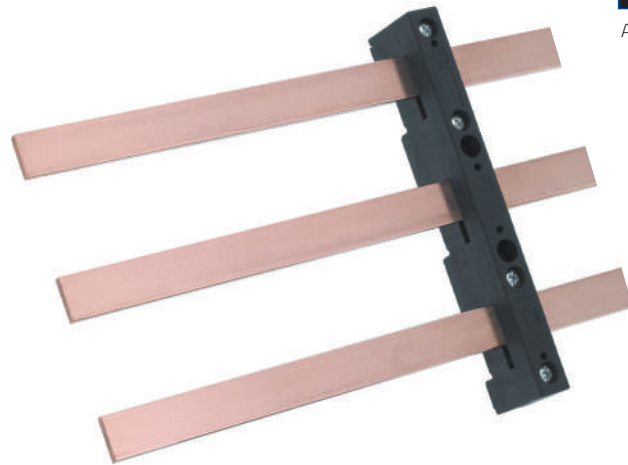

Dimensions

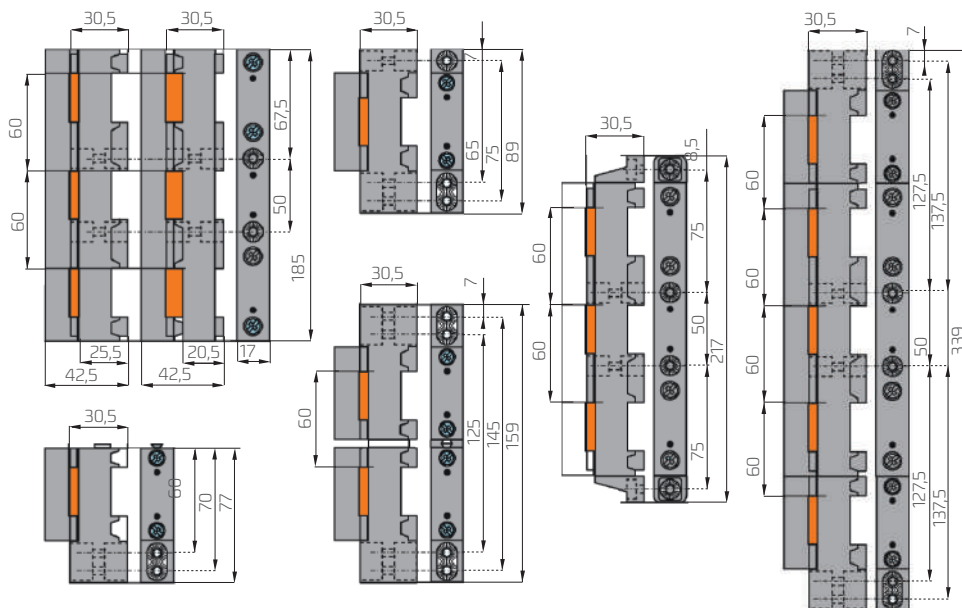

APASYS 60 ACCESSORIES

Table 110. Versions

Position	Index no.	Weight [kg]	Package [pcs.]
3-pole, 2 mounting holes inside, washers and screws included	0000106300T	0,121	20
Component included with 0000106300T, with a mounting hole for devices requiring 4 mounting holes, screws included	0000106301T	0,006	10
1-pole, included with 0000106300T or to build a 2-pole support, washers and screws included	0000106302T	0,048	10
1-pole for a single device, washers and screws included	0000106304T	0,056	10
Connector, allows mounting 2 x 0000106302T to receive 2-pole support	0000106307T	0,004	10
3-pole terminal cover, yellow with a warning triangle	0000106303T	0,019	10
3-pole terminal cover, Z type, yellow with a warning triangle	0000106308T	0,024	10
1-pole terminal cover	0000106310T	0,006	10
1-pole terminal cover, Z type	0000106311T	0,007	20
Screw 25 mm	0000106309T	0,004	20
Screw 10 mm	0000106312T	0,002	10
2-pole Busbar support; 1 mounting hole	0000106004T	0,08	10
2-pole Busbar support; 2 mounting holes	0000106005T	0,09	10

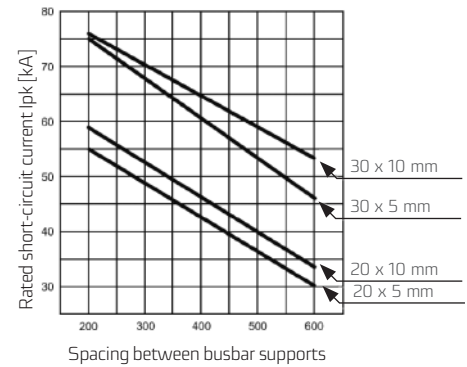
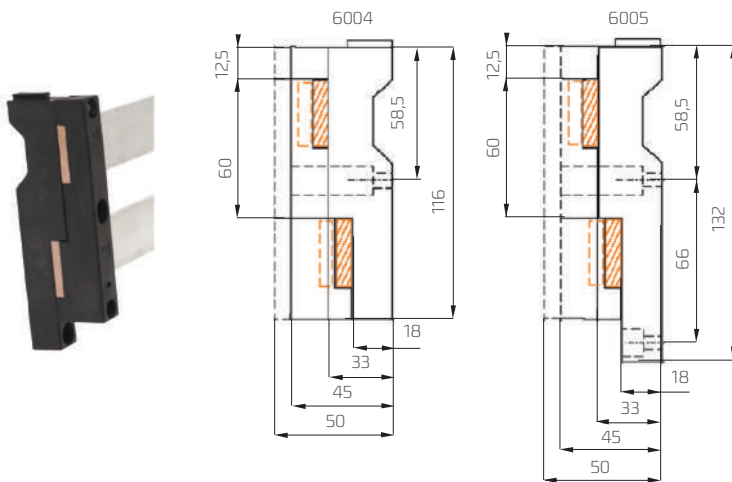

Short-circuit resistance diagram according to DIN EN 60439
60 mm busbar system
Rated operating voltage: 690 V, Rated frequency: 50 Hz

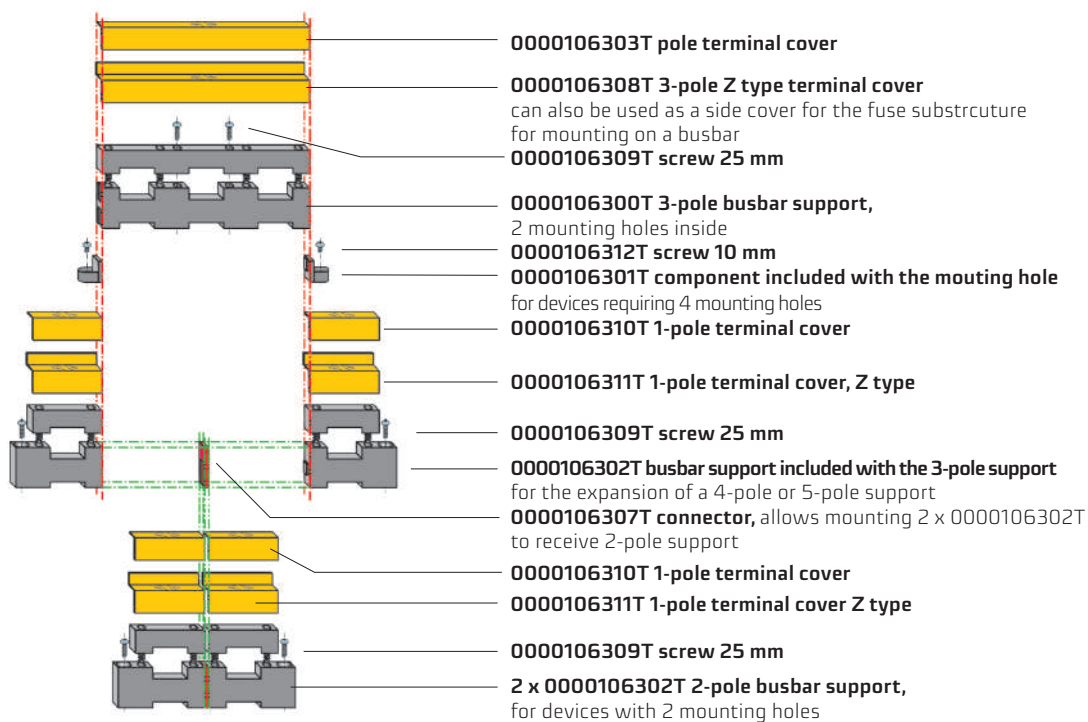

For the 60 mm, 100 mm and 185 mm system

- The supports are characterised by a robust construction and insulating properties, thanks to which they are used in electrical switchboards as support elements for current busbars.
- The supports allow you to mount a busbar with spacing of 60, 100, 185 mm.
- The body is made of insulating material (polyester reinforced with glass fibre), in which M10 threads are embedded (maximum tightening torque: 25 Nm).



APASYS 60



Table 111. Technical data

Classification	
Flammability class	V0
Track resistance	CTI 600
Heat resistance	960°C

Dimensions

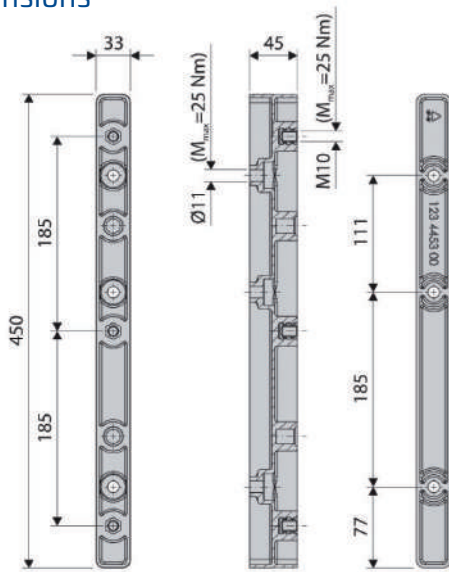

M10 185
0000188105T

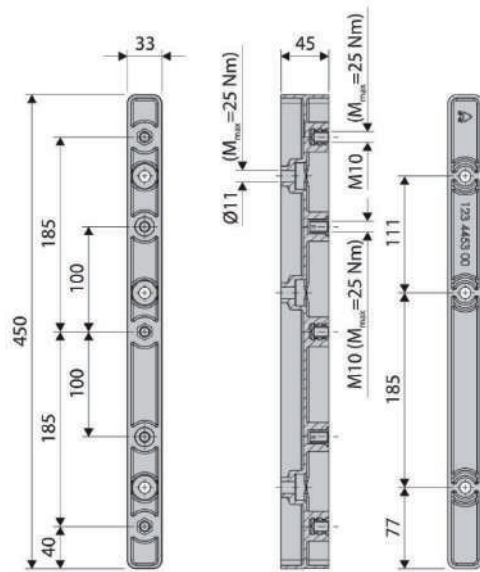

M10 185/100
0000188106T

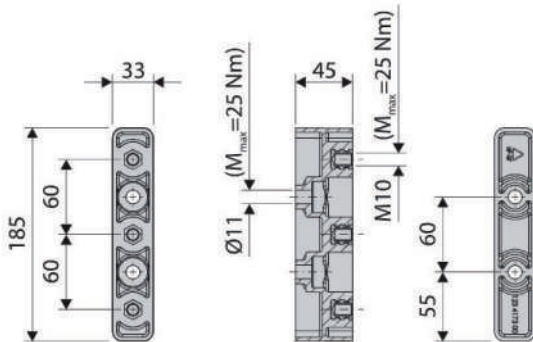

M10 60
0000188107T

Table 112. Versions

Position	Index no.	Weight [kg]	Package [pcs.]
Busbar spacing 60 mm, 3-pole busbar support, with seated M10 nuts (M10 60)	0000188107T	0,23	1
Busbar spacing 100 mm, 3-pole busbar support, with seated M10 nuts (M10 185/100 mm)	0000188106T	0,48	1
Busbar spacing 185 mm, 3-pole busbar support, with seated M10 nuts (M10 185 mm)	0000188105T	0,46	1

Short-circuit resistance of 5 mm thick busbar depending on the distance between supports (busbar spacing 100 mm)

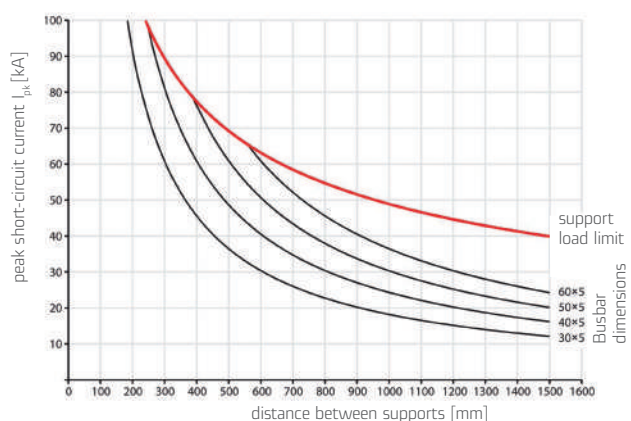

Short-circuit resistance of 10 mm thick busbar depending on the distance between supports (busbar spacing 100 mm)

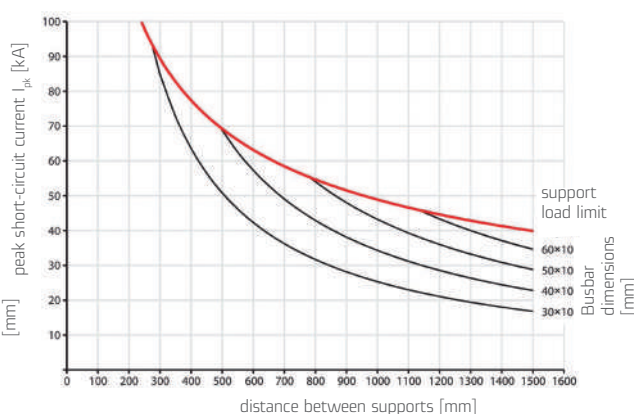

Short-circuit resistance of 5 mm thick busbar depending on the distance between supports (busbar spacing 185 mm)

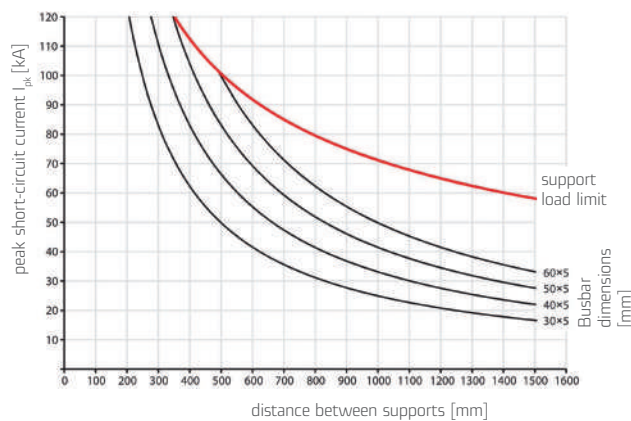

Short-circuit resistance of 10 mm thick busbar depending on the distance between supports (busbar spacing 185 mm)

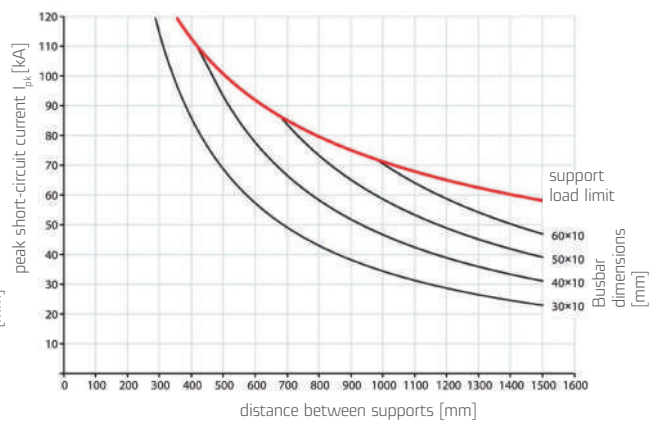

POWER ADAPTER



APASYS 60

The APASYS 60 power supply connections are implemented using a universal hook terminal that adapts to the busbar section. Protective covers provide the required level of safety.

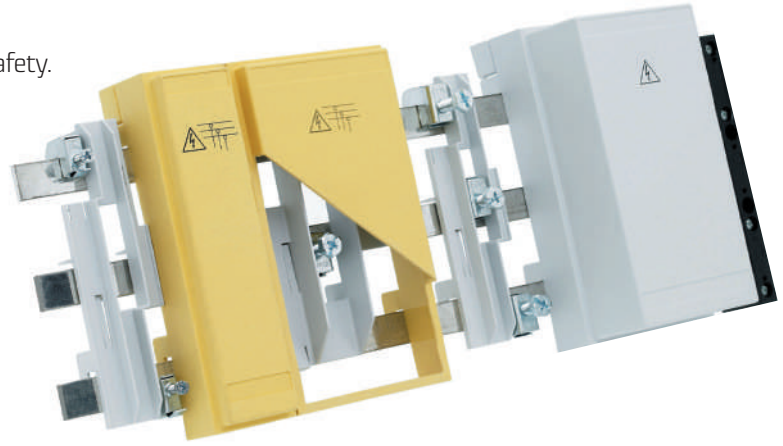

Dimensions

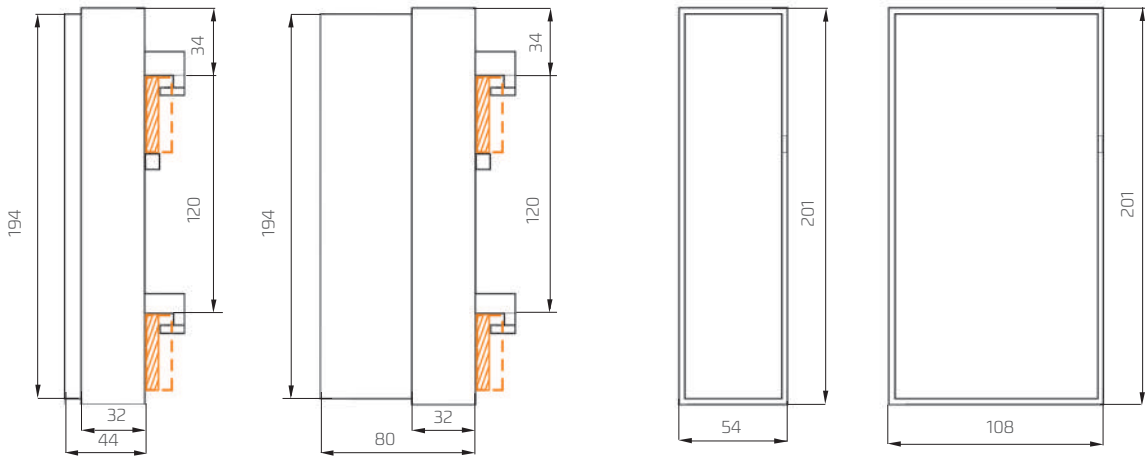

POWER ADAPTER

APASYS 60 ACCESSORIES

Table 113. Power adapters (without hook terminals) with warning triangle for busbar and cable protection

Versions (yellow colour)	Index no.	Weight [kg]	Package [pcs.]
Width 54 mm, internal height 42 mm, for terminals 16..50 mm ²	0000106090T	0,11	2
Width 108 mm, internal height 42 mm, for terminals 16..70 mm ²	0000106091T	0,17	1
Width 108 mm, internal height 78 mm, for terminals 16..185 mm ²	0000106092T	0,22	1
Versions (gray colour)	Index no.	Weight [kg]	Package [pcs.]
Width 54 mm, internal height 42 mm, for terminals 16..50 mm ²	0000106096T	0,11	2
Width 108 mm, internal height 42 mm, for terminals 16..70 mm ²	0000106097T	0,17	1
Width 108 mm, internal height 78 mm, for terminals 16..185 mm ²	0000106098T	0,22	1

Table 114. Busbar bridge cover, grey colour

Versions	Index no.	Weight [kg]	Package [pcs.]
Width 54 mm, internal height 42 mm	0000106033T	0,09	2
Width 108 mm, internal height 42 mm	0000106034T	0,12	1
Width 108 mm, internal height 78 mm	0000106035T	0,12	1



Table 115. Hook terminals

Versions for 5 mm thick busbars	Index no.	Weight [kg]	Package [pcs.]
1,5..16 mm ²	0000116051T	0,03	100
1,5..35 mm ²	0000116052T	0,04	50
1,5..50 mm ²	0000116053T	0,05	50
16..70 mm ²	0000116054T	0,06	10
16..120 mm ²	0000116055T	0,09	10
16..185 mm ²	0000116056T	0,10	10
Versions for 10 mm thick busbars	Index no.	Weight [kg]	Package [pcs.]
1,5..16 mm ²	0000116061T	0,03	100
1,5..35 mm ²	0000116062T	0,04	50
1,5..50 mm ²	0000116063T	0,05	50
16..70 mm ²	0000116064T	0,06	10
16..120 mm ²	0000116065T	0,09	10
16..185 mm ²	0000116066T	0,10	10

E18 FUSE BASE

for mounting on a busbar



APASYS 60

- Ability to add a description of each phase.
- Stainless steel connection terminals with low power loss.
- Side insulation covers to protect against accidental contact.
- Snap-on rear insulation cover.

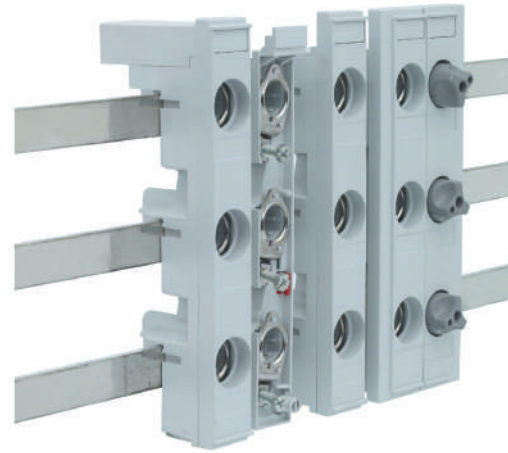

Table 116. Technical data

3-POLE ; DIN 49524	
For D0 fuse links	2...63A DIN 49522
Adapter - holder	D02 DIN 49523 400 V AC/250 DC 50 kA _{eff}
Steel frame terminal	1,5...25 mm ² , 3-4 Nm
Track resistance	CTI 600
Flammability class	UL 94-V0
Heat resistance	200 °C
Glowing wire attempt	960 °C

Table 117. Versions

Position	Index no.	Weight [kg]	Package [pcs.]
Fuse substructure for mounting on a busbar 27 mm, without cover	0000106022T	0,15	10
Fuse substructure for mounting on a busbar 27 mm, with cover	0000106023T	0,17	10
Fuse substructure for mounting on a busbar 36 mm, with cover and side widener	0000106028T	0,19	10
Fuse substructure for mounting on a busbar 54 mm, with coverandside widener	0000106029T	0,21	10
Cover 27 mm	0000106011T	0,02	10
Cover 36 mm, includes side widener	0000106012T	0,03	10
Cover 54 mm, includes side widener	0000106013T	0,05	10
Pair of covers	0000106016T	0,05	10
Single cover left	0000106017T	0,02	10
Single cover right	0000106018T	0,02	10
Snap-on cover providing protection against contact	0000106026T	0,01	10

Fuse substructure should be equipped with fuse carriers (see Table 44. Accessories)

Dimensions

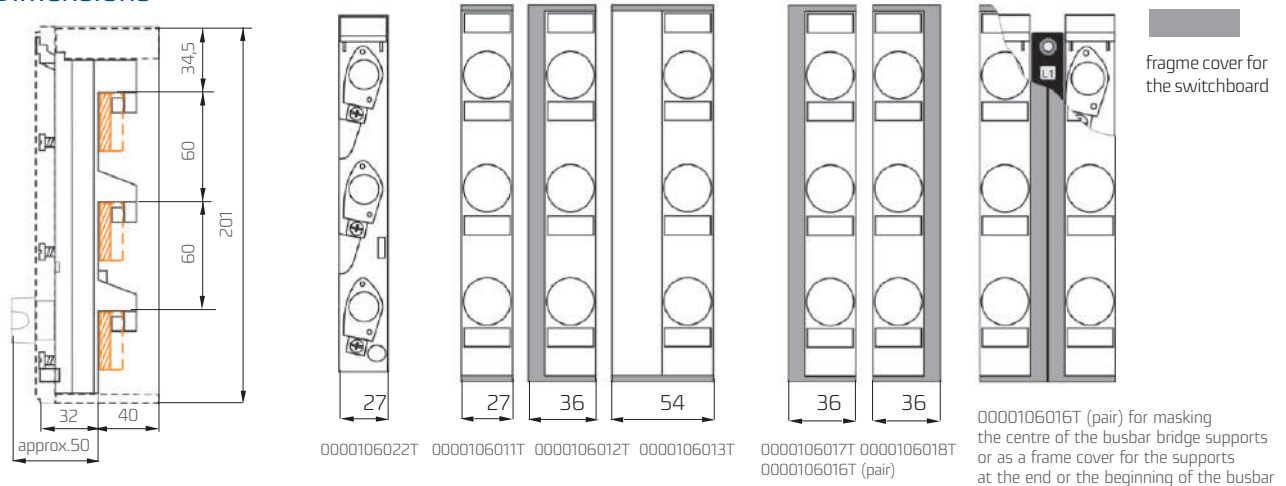

E18 FUSE SUBSTRUCTURE

ADAPTER FOR COMPONENT ASSEMBLY

APASYS 60 component adapter with infinitely adjustable mounting support and double terminals with low power loss

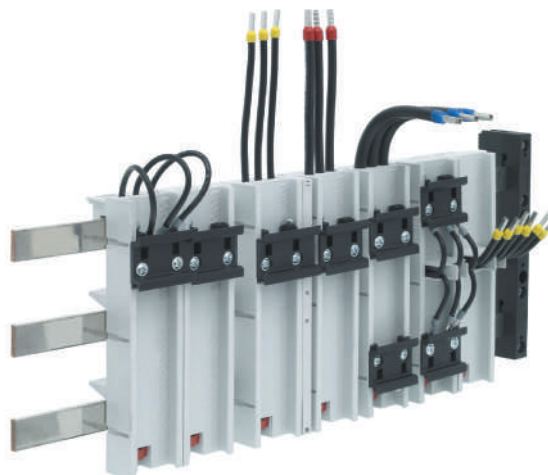
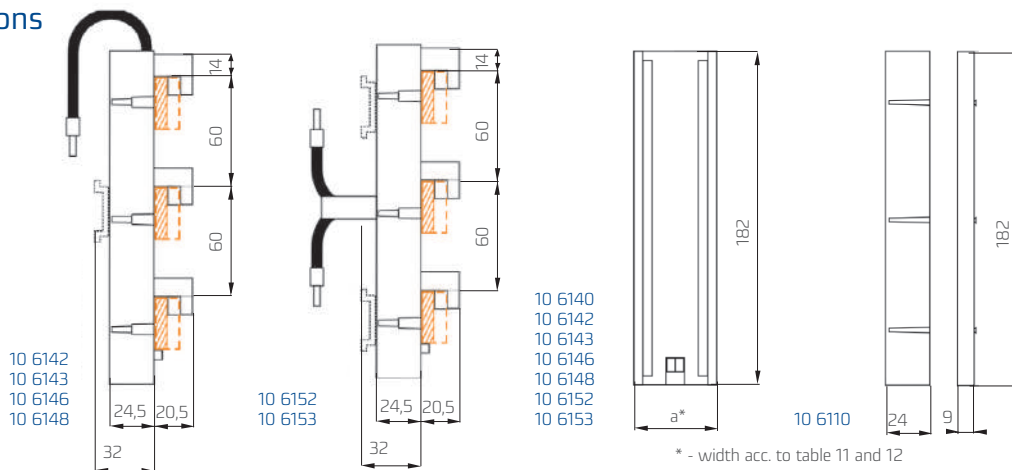

Table 118. Versions

Position	Index no.	Weight [kg]	Package [pcs.]
$I_n=25$ A section of the connection cable AWG 12 / 4 mm²			
1 universal mounting rail, width 45 mm	0106142451T	0,21	2
2 universal mounting rails, width 45 mm	0106142452T	0,23	2
1 universal mounting rail, width 54 mm	0106142541T	0,22	2
2 universal mounting rails, width 54 mm	0106142542T	0,24	2
$I_n=35$ A section of the connection cable AWG 10 / 6 mm²			
1 universal mounting rail, width 45 mm	0106143451T	0,22	2
2 universal mounting rails, width 45 mm	0106143452T	0,24	2
1 universal mounting rail, width 54 mm	0106143541T	0,23	2
2 universal mounting rails, width 54 mm	0106143542T	0,25	2
1 universal mounting rail, width 63 mm	0106143631T	0,27	2
1 universal mounting rail, width 72 mm	0106143721T	0,29	2
2 universal mounting rails, width 81 mm	0106143812T	0,31	2
$I_n=63$ A section of the connection cable AWG 8 / 10 mm²			
1 universal mounting rail, width 54 mm	0106146541T	0,26	2
2 universal mounting rails, width 54 mm	0106146542T	0,28	2
1 universal mounting rail, width 63 mm	0106146631T	0,30	2
1 universal mounting rail, width 72 mm	0106146721T	0,32	2
2 universal mounting rails, width 81 mm	0106146812T	0,34	2
$I_n=80$ A section of the connection cable AWG 6 / 16 mm²			
1 universal mounting rail, width 54 mm	0106148541T	0,29	2
2 universal mounting rails, width 54 mm	0106148542T	0,31	2
1 universal mounting rail, width 63 mm	0106148631T	0,33	2
1 universal mounting rail, width 72 mm	0106148721T	0,35	2
2 universal mounting rails, width 81 mm	0106148812T	0,37	2

Dimensions



ADAPTER FOR COMPONENT ASSEMBLY

COMPONENTS MOUNTING ADAPTER

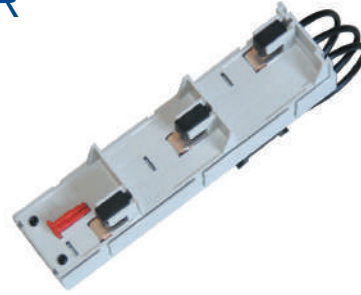

Table 119. Versions

Position	Index no.	Weight [kg]	Package [pcs.]
$I_e = 25$ A; 4 mm ² section of the connection cable, AWG 12 width 45 mm	0000106142T	0,19	4
$I_e = 35$ A; 6 mm ² section of the connection cable, AWG 10 width 45 mm	0000106143T	0,20	4
$I_e = 63$ A; 10 mm ² section of the connection cable, AWG 8 width 45 mm	0000106146T	0,23	4
$I_e = 80$ A; 16 mm ² section of the connection cable, AWG 6 width 45 mm	0000106148T	0,26	4
$I_e = 25$ A; double central terminal 4 mm ² , AWG 12 width 45 mm	0000106152T	0,20	4
$I_e = 35$ A; double central terminal 6 mm ² , AWG 10 width 45 mm	0000106153T	0,25	4
Without terminals, contains connector X for side extension or single mounting	0000106140T	0,15	4

ACCESSORIES

Table 120. Versions

Position	Index no.	Weight [kg]	Package [pcs.]
Side element for adapter expansion, width 9 mm	0000106110T	0,02	10
Universal mounting rail, width 45 mm, stepless adjustment	0000106104T	0,02	10
Universal mounting rail, width 54 mm, stepless adjustment	0000106105T	0,02	10
Universal mounting rail, width 63 mm, stepless adjustment	0000106106T	0,02	10
Universal mounting rail, width 72 mm, stepless adjustment	0000106107T	0,02	10
Universal mounting rail, width 81 mm, stepless adjustment	0000106108T	0,02	10

The mounting rails are steplessly adjustable.



Adapter base



Side element, width 9 mm allows to expand adapter base by 9 mm



Mounting rail installed on the base by means of a double wedge element



Set up the mounting rail in the correct position and tighten the screws



1. Place the APASYS 60 component on the top mounting rail and connect the power supply
2. Place the second component on the bottom mounting rail. Adjust the mounting rail to match the position of the component and connect it



Tighten the bottom mounting rail

Double contact area

1. Double contact area
2. Terminal
3. Steel spring loaded terminal block
4. 5 mm connection terminal with CuAg contact
5. Busbar

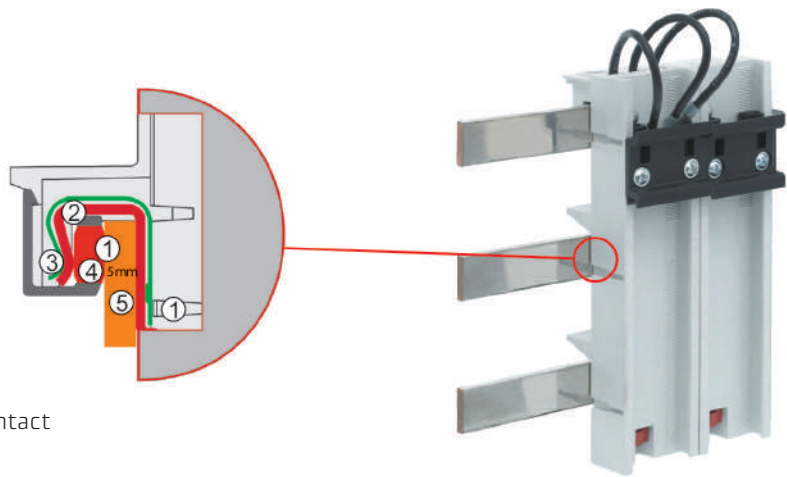

Double contact area design provides low power loss.
The pressure is applied only by the metal parts and not the plastic.

RBD0/60

Fuse switch disconnecter for D0 fuse links for busbar mounting



APASYS 60

RBD0/60

Disconnecter with D02 fuse switches for installation on a busbar with fuse switches holders with an optoelectrical light indicator

RBD0/60 primary security

with relay for monitoring fuse link condition and temperature

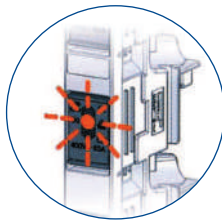

Light indicator
Damage to the fuse link is reliably detected and indicated by an optoelectrical indicator

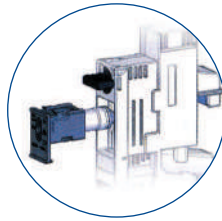

Quick and easy replacement of the fuse link
Fuse switch holder allows for quick and easy replacement of the D0 fuse link

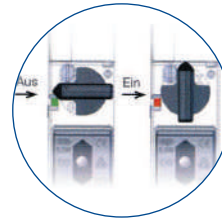

Operating status indicator
The colour of the operating status indicator enables an immediate evaluation of the operating status of the connector

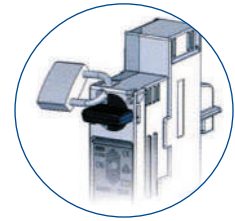

Padlock
The padlock prevents unauthorized change of the disconnecter switch-on status

Table 121. Technical data

Classification	Fuse switch disconnecter
Standard	IEC 947-3
Adapted to D0 fuse links DIN 49522	D01: 2, 4, 6, 10, 16 AgL, gG, aM D02: 20, 25, 32, 35, 40, 50, 63 AgL, gG, aM
Adapted to cylindrical fuse links IEC 60269-1	10 x 38 mm: 2, 4, 6, 8, 10, 12, 16, 20, 25, 32A
Flammability class/track resistance	UL94 / V0, glowing wire attempt 960°C / CTI 600
Degree of protection/touch protection	IP20 / protection against finger and palm touch
Rated switching voltage U_e	
-D0	400 V AC
-10 x 38	500 V AC
Rated switching current I_e	D0: 63A; 10 x 38: 32 A
Overvoltage category/pollution degree	IV/3 (DIN VDE 0110)
Rated impulse withstand voltage U_{imp}	6000 V
Terminal type	stainless steel frame terminal 1,5...25 mm ² ; M_D 3,5 Nm, cross recess
Rated short-circuit switch-on capability I_{cm}	50 kA _{eff}
Utilization category	AC 22B
Busbar dimensions	width: 12 mm-30 mm; thickness: 5 mm and 10 mm

Table 122. RBD0 - Versions

Position	Index no.	Weight [kg]	Package [pcs.]
400 V~, D0:2...63 A; 10x38: 2...32 A 400 V~,			
3-pole	0000106601T	0,40	3
3-pole + neutral pole N	0000106602T	0,40	3
3-pole with microswitch for switching status signalling	0000106603T	0,40	3
3-pole + neutral pole N with microswitch for switching status signalling	0000106604T	0,40	3
500 V~, 10x38: 2...25 A			
3-pole	0000106631T	0,40	3
3-pole + neutral pole N	0000106632T	0,40	3
3-pole with microswitch for switching status signalling	0000106633T	0,40	3
3-pole + neutral pole N with microswitch for switching status signalling	0000106634T	0,40	3
Rear contact guard, top and bottom	0000106626T	0,01	10
Adapter reducing spring for the D01 and D02 fuse link	0000101774T	0,01	12
Padlock in busbar snap-on container	0000104664T	0,05	1
Pin used as a solid link	0000101780T	0,01	3

Dimensions

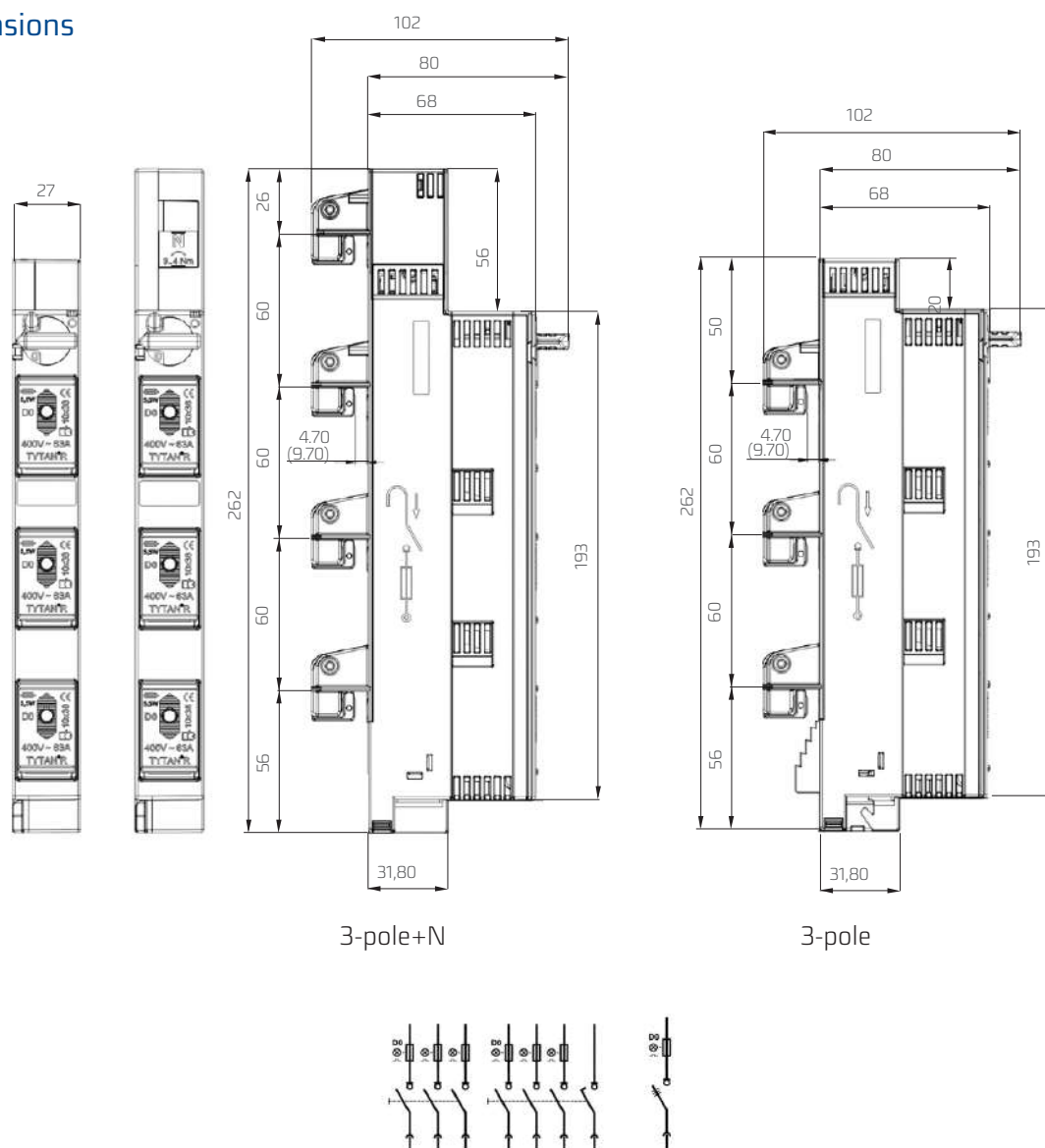

RBD0/60

Primary security



APASYS 60

RBD0 - main protection switch indicates fuse breaks and has the capability of transmitting a floating signal via an RJ-connection cable on the external relay. A dangerous overheating of the fuse switch can be reliably identified and reported. The serial interface on each relay has a floating signal via a relay contact. For collective disturbance monitoring it is possible to put 12 fuse switches together.



Table 123. RBD0/60 - main protection with control of the fuse link status and temperature

Versions	Index no.	Weight [kg]	Package [pcs.]
400 V~, D0:2...63A; 10x38: 2...32A			
RBD0/60 H1 3-pole	0000106701T	0,40	3
RBD0/60 H1 3-pole + neutral pole N	0000106702T	0,40	3
500 V~, 10x38: 2...25A			
RBD0/60 H1 3-pole	0000106731T	0,40	3
RBD0/60 H1 3-pole + neutral pole N	0000106732T	0,40	3
Relay module of the primary security HR11; 3 -terminals (indicates fuse link burnout, overtemperature, turning on/off)	0000103711T	0,12	1
Relay module of the primary security HR12; 2 -terminals (indicates fuse link burnout, overtemperature)	0000103712T	0,12	1
Relay module of the primary security HR13; 1 -terminal (indicates fuse link burnout, overtemperature)	0000103713T	0,12	1
RJ cable, length 200 mm	0000103730T	0,01	1
RJ cable, length 500 mm	0000103731T	0,01	1
RJ cable, length 1000 mm	0000103732T	0,01	1
Network adapter 100-240 V AC/24 V DC 10 W	0000103700T	0,10	1
Network adapter 100-240 V AC/24 V DC 30 W	0000103701T	0,25	1

RBD0/60 main protection signalises the fuse activation and transmits information by means of an RJ cable to externally placed safety automatics devices. At the same time, unsafe overheating of the device is shown and reported.

Interface - a voltage-free connection terminal is available in the relay section.

There is a possibility of collective signalling of any irregularities through serial connection of devices. The collective signal can handle up to 12 devices.

Power supply for the relay part: 24 V DC

Outputs of the relay part:

- 1 terminal for the fuse link burnout
- 1 terminal for overtemperature
- 1 terminal for the on/off position

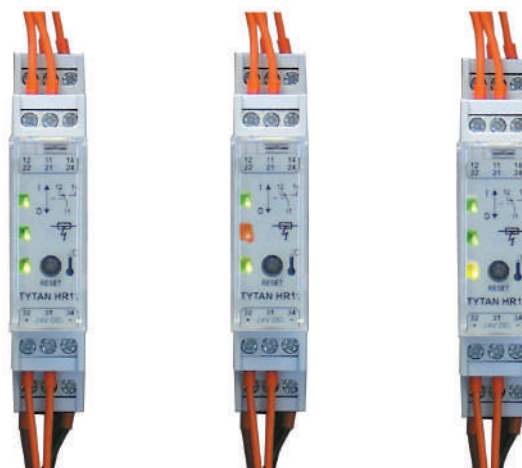

Correct operating status

Fuse link burnout

Overtemperature in the device

Dimensions

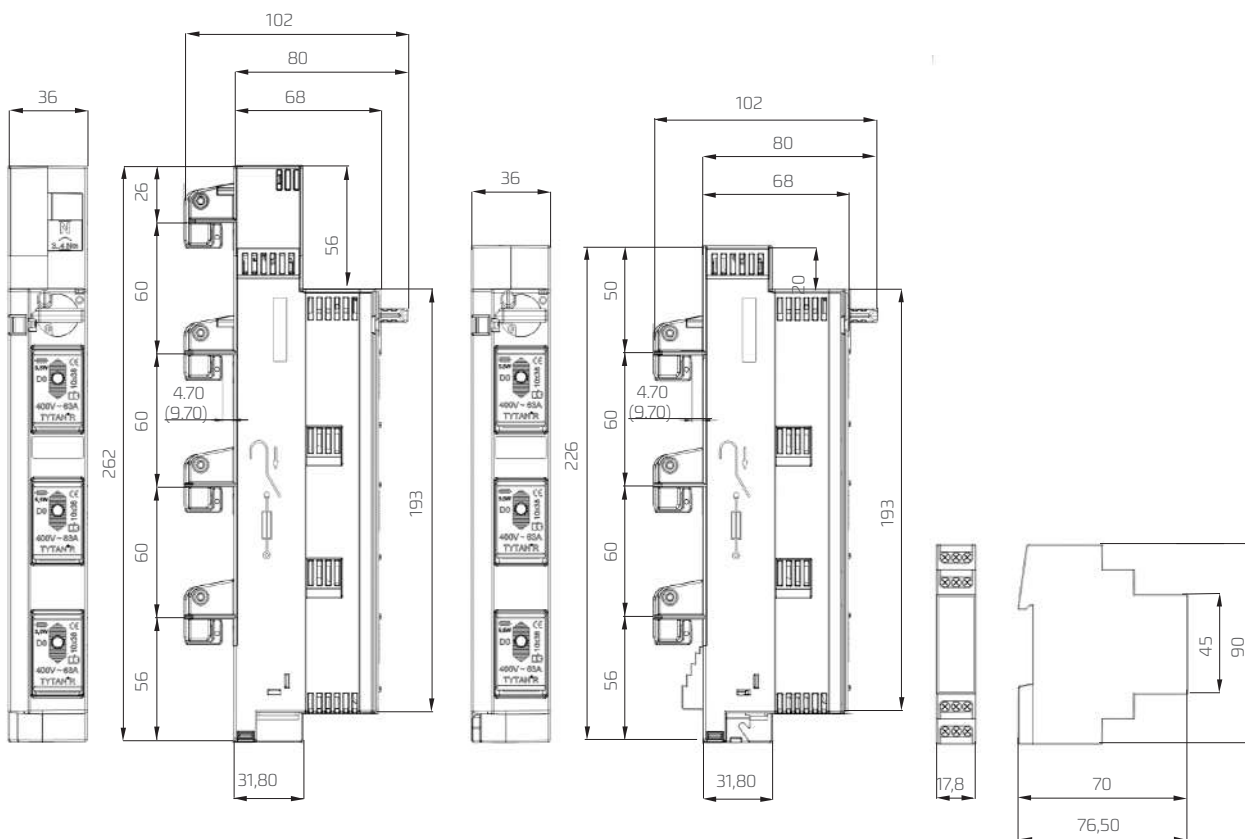

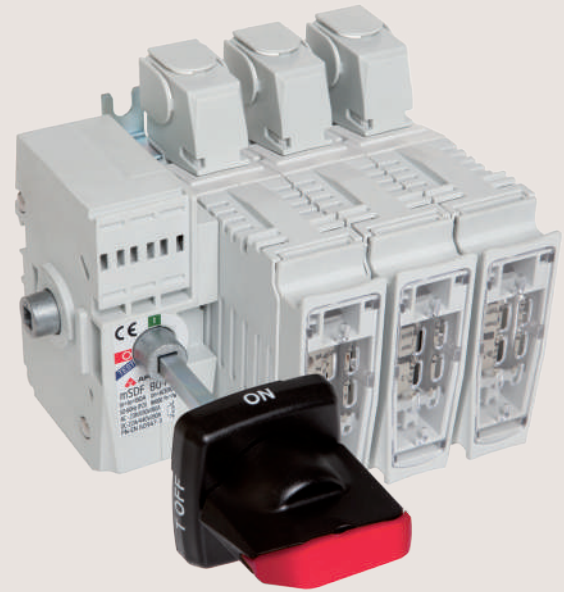

mSDF 80

Fuse switch disconnector

mSDF 80

Fuse switch disconnecter

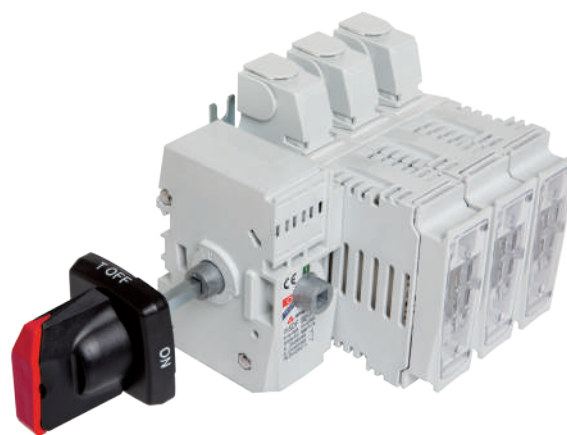

mSDF 80 is the smallest fuse switch disconnecter in the **COMPASS** family designed for fuse size NH 000 to 80 A. The **COMPASS** fuse switch disconnecter family redefines safety of service and ergonomics. The name **COMPASS** is a combination of two words: **COMP**act and **AS**sembly, which characterise its main features.

The **mSDF** fuse switch disconnecter from the **COMPASS** family has been designed in accordance with applicable standards PN-EN 60947-31, PN-EN 60947-3, IEC 60947-1, and IEC 60947-3.

FUNCTIONALITY

- Safety of service and easy installation
- Cover lock preventing removal of the fuse in „on“ position
- Self-extinguishing thermoplastics (V0 flammability class)
- Operating shaft front side and drive side
- Possibility to directly install 3 microswitches (further can be installed on levels)
- Door interlock in „on“ position - release mechanism for opening using a tool
- Self-cleaning contacts
- High electrical and mechanical endurance
- High short-circuit making and breaking capacity
- Double, safe clearance between open contacts
- Complete isolation of fuse links in „off“ position
- Wide range of accessories

APPLICATIONS

COMPASS fuse switch disconnecters are designed for distribution of electricity and protection against short circuits and overloads in three phase alternative current circuits. **mSDF 80** disconnecters can perform the following functions:

- Disconnectors for controlling and securing engines and other alternating current devices
- Switch disconnectors in switchgear

OPERATING CONDITIONS

- To be installed in the room free of any dust, aggressive or explosive gases
- Altitude up to 2000 meters above sea level
- Outdoor – in cabinets with protection degree > IP34
- Ambient temperature from -5°C to 40°C
- Transport and storage temperature from -25°C to 55°C
- Relative humidity of the air should not be higher than 50% at temperature of +40°C

CONSTRUCTION

mSDF 80 fuse switch disconnectors of the **COMPASS** family are manufactured in two versions:

- Three pole (P3)
- Four pole (P4)

mSDF 80 fuse switch disconnecter is characterised by its modular construction which enables assembling a version composed of three or four identical functional blocks - modules - fixed to the drive. **mSDF 80** disconnecter is characterised by small external dimensions facilitating its application in switchgear with pull-out trays.

mSDF 80 fuse switch disconnecter is designed for currents up to 80 A for gG fuse size NH 000. **mSDF 80** disconnectors are designed for installation both on TH35 busbar system and on a mounting plate using special holders.

All plastic parts of **COMPASS** family disconnectors are made of halogen free, fibre glass strengthened, self-extinguishing materials. Thanks to the application of flame retardants the highest flammability class – V0 is achieved. Disconnectors made from such thermoplastics self-extinguish in specified time after ignition source is removed. Also falling off and dripping of flaming parts of plastic does not occur.

mSDF 80 fuse switch disconnecter has an operating shaft which can be installed from the front side of the disconnecter and from the drive side. Special construction of the handle indicates the position of the disconnecter, making it possible to achieve three positions (ON, OFF, and TEST). What is more, the handle is designed for locking by up to 3 padlocks $\phi 6$ standard in OFF position. **mSDF 80** fuse switch disconnecter allows to connect wiring to clamps, which can be used to signal voltage or to control fuse link burnout. Silver plated contacts **mSDF 80** provide low power loss. Frame type clamps applied in **mSDF 80** facilitate direct connecting of isolated ends of wires up to 35 mm² section. The disconnecter provides IP 20 degree of protection. **mSDF 80** fuse switch disconnecter enables installation of two sizes of cover clamps - long or short - depending on the customer's demand.

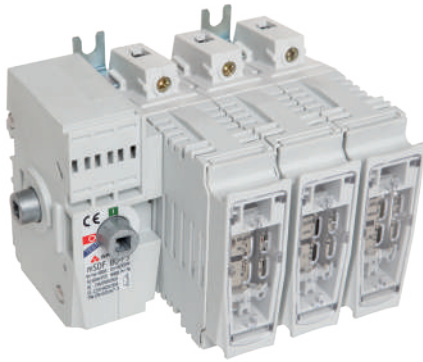

mSDF 80-P3

Table 124. Technical data

Parameters	mSDF 80 disconnectors			
Rated thermal current $I_{th}=I_n$	A	80		
Rated voltage U_n	V	690	1000	
Utilization category	-	AC-23A	DC-22A	AC-20A DC-20A
Rated switching current I_e	A	80	80	- -
Rated switching voltage U_e	V	690	440	- -
Rated short-circuit breaking capacity I_{cm}	kA	7	16	- -
Rated impulse withstand voltage U_{imp}	kV	8		
Rated insulation voltage U_i	V	1000		
Rated frequency	Hz	50-60		
Mechanical durability	number of cycles	10000		
Electrical durability	connecting cycles	1500		
Duty		Continuous duty		
Protection degree		IP 20		
Fuse links size		000		

Table 125. mSDF 80 versions

Version		Weight	Article no.
mSDF 80-P3	3-pole switch fuse disconnectors to be installed on a plate	1 kg	63-002264-001
mSDF 80-P3-E	3-pole switch fuse disconnectors to be installed on a TH 35 busbar	1 kg	63-002264-002
mSDF 80-P4	4-pole switch fuse disconnectors to be installed on a plate	1,3 kg	63-002264-003
mSDF 80-P4-E	4-pole switch fuse disconnectors to be installed on a TH 35 busbar	1,3 kg	63-002264-004

Table 126. mSDF 80 terminal clamps

Clamp	Frame
Drawing of clamp	
Cross-section of conductors	rm 2,5 - 25mm ² re 2,5 - 35 mm ²
Tightening torque	4 Nm



mSDF 80-P3 with an additional C1 cover

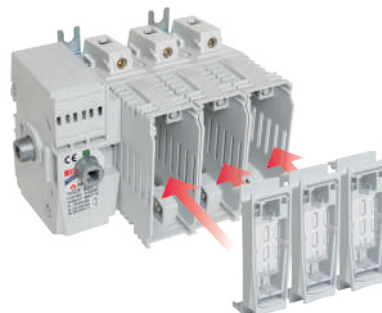

mSDF 80-P3



mSDF 80-P3 with an additional C2 cover

ORDERING

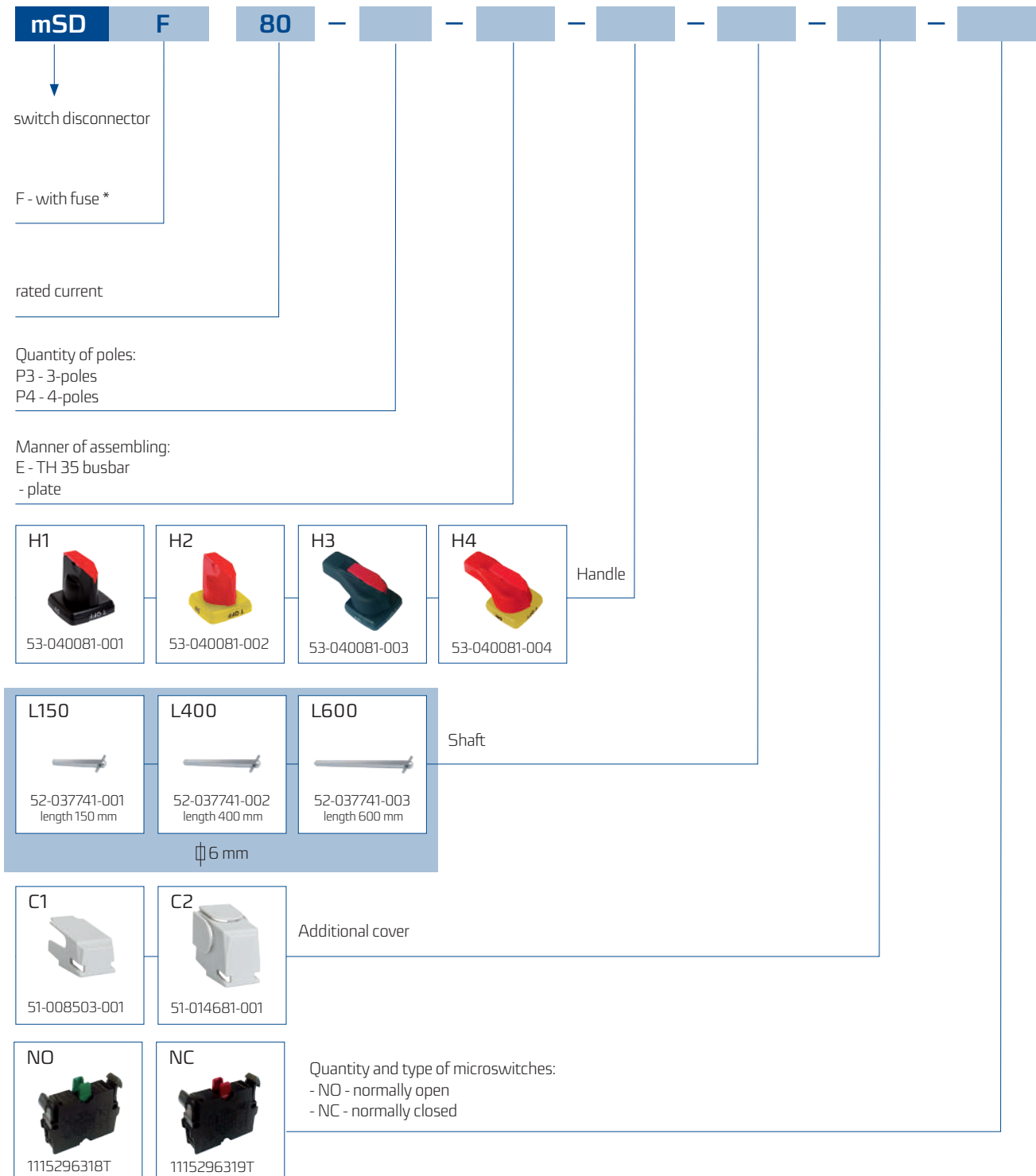

* a fuse switch disconnecter is sold without fuse links

Example

mSDF 80-P3-H2-L150-C2-2NO1NC

a fuse switch disconnecter, $I_n = 80 \text{ A}$, installed on a plate, with a H2 handle and a shaft 150 mm long with long C2 covers with 2 microswitches normally open and 1 microswitch normally closed

DIMENSIONS

mSDF 80

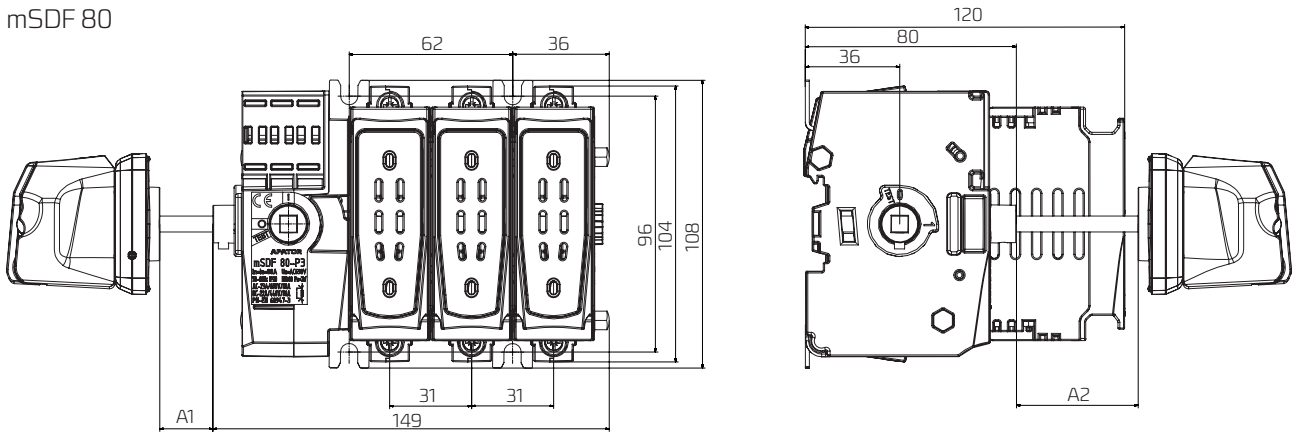

mSDF 80 with a short additional cover C1

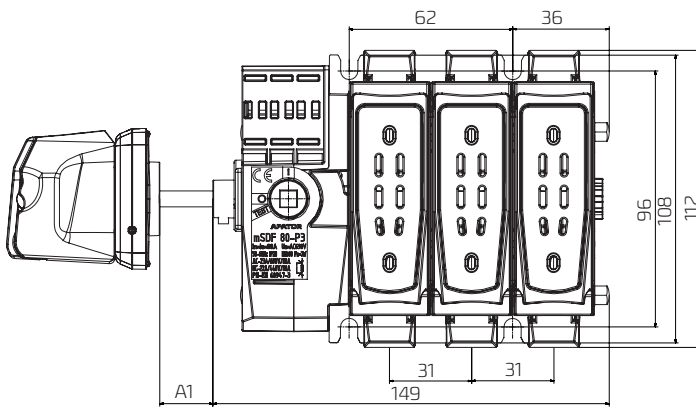

mSDF 80 with a long additional cover C2

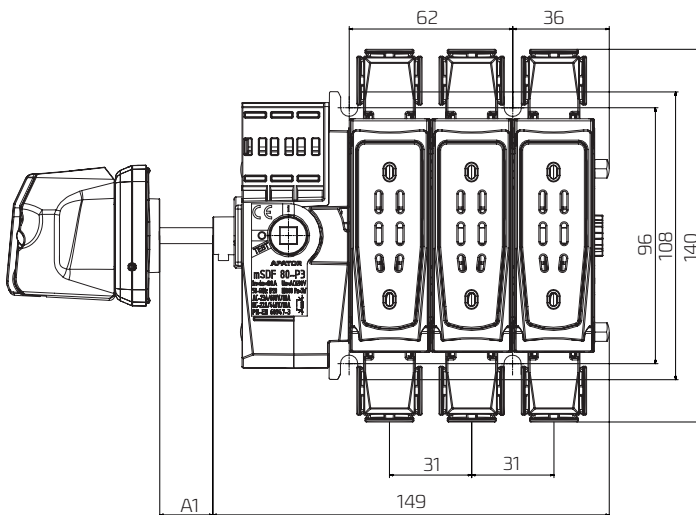

Shaft* [mm]	A1 [mm]	A2 [mm]
150	10÷110	45÷110
400	10÷360	45÷360
600	10÷560	45÷560

*A shaft going through a device shall be cut as needed.

Distribution of holes for handle assembly [mm]:

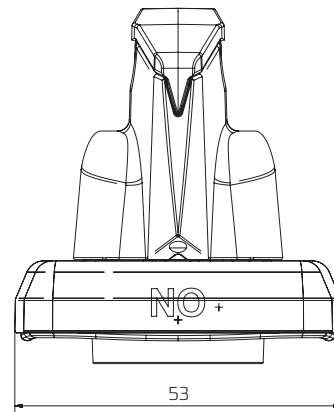
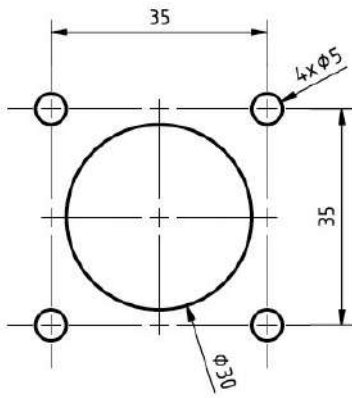

Fastening screws (4 pcs): M4 x h, where $h[\text{mm}] = 8 + \text{wall thickness}$

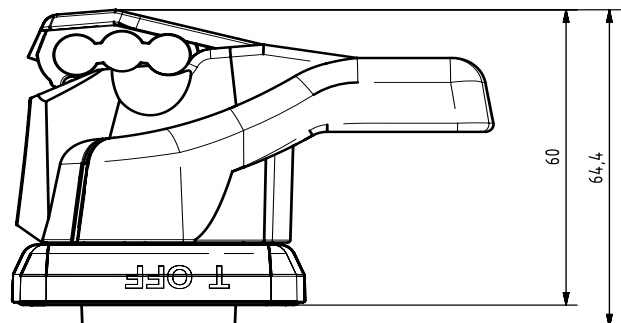
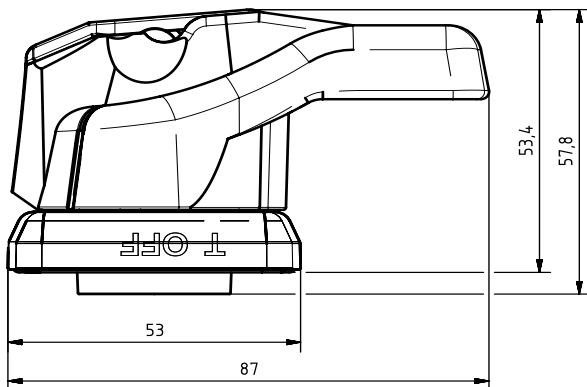
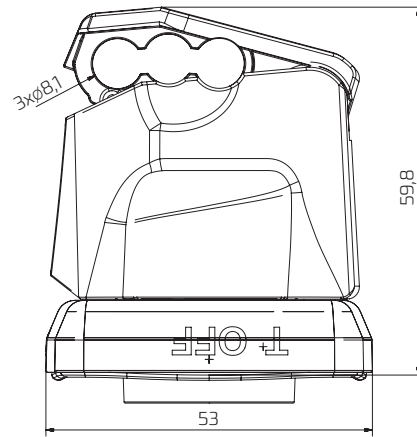
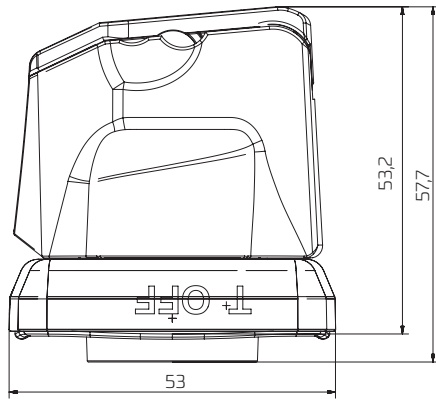



4G

Cam switches

GENERAL INFORMATION

4G-series cam switches are low voltage switches, designed according to the latest knowledge about switchgear and using the achievements of modern engineering. Only high quality insulation and contact materials have been used in these products. Basic components and units are standardized and massproduced, making it possible to make switches performing any switching programs, and short delivery terms.

Switches can be produced in many versions and have various applications. They conform all requirements for low voltage switches in industry, mining, shipbuilding, etc. They can be used as handoperated switches in transformer stations, control switchboxes and boards, switchgears made of cast iron or other metals, welding machines and similar devices.

4G-series switches are characterized by small external dimensions, powerful switching capabilities, long contact life and high mechanical stability, and resistance to short-lasting overloads. When additionally protected with fuses, they are also resistant to dynamic effects of short-circuit currents.

APPLICATION

Cam switches can be used in main and auxiliary circuits, especially:

- as switches for electric motors for switching and controlling the drives with single- and three-phase motors, as stardelta switches, reversing switches and switches for changing the rotational speed, etc.,
- in auxiliary, controlling, signalling and measuring circuits, manufactured according to the required switching program,
- as breaker switches, change-over switches and tap switches, for example for transformers and electric welding machines,
- as switchgroups, for example to connect resistors and heating elements,
- as change-over switches working as push-buttons with automatic returning to an off position,
- as switch disconnectors.

CONFORMITY WITH STANDARDS

4G-series cam switches fully comply with the requirements of the following standards: 93/E-06150/10, 93/E-06150/30, IEC 947-1, IEC 947-3.

These switches have Recognition Certificate of the Polish Register of Shipping, and CE Declaration of conformity of the European directive 73/23/EEC.

DIVISION

Basic division of switches and their marking is based on the rated current. Further division, based on external dimensions of the switches, enables to distinguish three groups characterized by overall dimensions. Each group has the same knobs, front plates and spacing for mounting holes.

Table 127. Division into groups

Group	A0		A1		A2		A3
Switch type	4G10	4G16	4G25	4G40	4G63	4G80	4G100
Rated current I_n [A]	10	16	25	40	63	80	100

DESIGN

Depending on the switching program, every cam switch consists of a certain number of switching elements, which can be easily assembled together. Switching elements' bodies are made of plastics based on melamine, especially resistant to the effects related to creep currents and electric arcs.

A switching element has one or two current circuits arranged at the angle of 180° and equipped with contact with a double contact gap. Each of them consists of two stationary contacts and one movable contact bridge. The contact bridge is switched on (pressed) by contact springs, and opened by a cam inside the switching element. The cams in individual switching elements are firmly coupled together, ensuring practically simultaneous switching (on and off) of all contacts. Thanks to the double gap contact assembly and contact tips made of special alloy containing silver and very resistant to effects of an electric arc, high switching capabilities and contact life have been obtained. Good clicking mechanism of a motion work ensures unfailing switching of moving contacts in respective fixed positions. The power springs of the clicking mechanism are different, depending on the number of the switching elements. According to individual requirements, cam switches can be made with the switching angles given in table 132.

Table 128. Connection angles

Group		A0	A1	A2	A3	Maximum number of handle positions
Connection angle	30°	•	•	•	•	12
	45°	•	•	•		8
	60°	•	•	•	•	6
	90°	•	•	•	•	4

Special stops are used to fix proper positions. Switching elements, driving mechanism and a rear plate (mounting plate) are connected into one unit with insulating bolts.

Special versions of cam switches can have more than 12 switching elements.

SUB-ASSEMBLIES

Front plate

Complete front plate consists of:

- a front plate with a place with black frame for a text; - an indicating plate cover (transparent),
- indicating plate (under the cover, standard version is white with black signs).

According to requirements, this plate can be black, yellow or silver.

HANDLE

The handle is used to control the switch. Black is a standard colour. According special to requirements, the handles can be supplied in red colour.

Table 129. Handle types



Group	A0	A1	A2	A3
	R012 red R014 black (standard)	R112 red R114 black (standard)	R212 red R214 black (standard)	R312 red R314 black (standard)
		R122 red R124 black	R222 red R224 black	R322 red R324 black

Table 130. Technical data

Parameter		Switch type												
		4G10	4G16	4G25	4G40	4G63	4G80	4G100	4G200	4G400	4G630	4G800	4G1200	
Rated insulation voltage U_i	V	690	690	690	690	690	690	690	690	690	690	690	690	
Rated impulse withstand voltage U_{imp}	kV	4	4	4	6	6	6	6	8	8	8	8	8	
Rated thermal current I_{th}	A	16	20	25	50	63	80	125	200	400	630	800	1200	
Short-circuit protection Rated breaking capacity of fuse links with high breaking capacity	10 kA _{sk}	A	–	25	25	50	63	80	125	200	400	630	2x400	2x630
	25 kA _{sk}	A	–	25	25	50	63	80	125	160	315	500	2x400	2x630
	40 kA _{sk}	A	–	25	25	50	63	80	125	160	315	400	500	2x400
	63 kA _{sk}	A	–	25	25	36	50	63	100	160	250	355	400	630
	75 kA _{sk}	A	–	25	25	36	50	63	100					
Mechanical durability (number of cycles)		3x10 ⁶	3x10 ⁶	3x10 ⁶	3x10 ⁶	3x10 ⁶	3x10 ⁶	3x10 ⁶	2x10 ⁵	2x10 ⁵	2x10 ⁵	2x10 ⁵	2x10 ⁵	
Terminal bolts Maximum cross-section of connecting conductors	mm ²	M3 2 x 2,5	M4 2 x 4	M4 2 x 6	M5 2 x 10	M5 2 x 10	M6 25	2 x M6 50	M6 –	M10 –	M12 –	M16 –	M16 –	
Short duration load capacity	1 s	A	220	430	690	920	1600	1600	2600	3300	6500	9500	12000	18000
	10 s	A	70	145	240	290	600	650	850	1100	2000	3000	4000	6100
	30 s	A	40	90	160	200	375	400	500	640	1200	1800	2400	3500
	60 s	A	30	75	125	155	285	300	360	460	850	1250	1600	2450
Breaking capacity	660 V - $\cos\phi = 0,65$	A	–	190	–	–	–	–	–	640	–	–	–	–
	660 V - $\cos\phi = 0,35$	A	–	–	250	490	500	500	650	–	–	–	–	–
	600 V - $\cos\phi = 0,35$	A	–	200	260	500	610	610	–	–	–	–	–	
	500 V - $\cos\phi = 0,35$	A	100 ¹⁾	–	–	–	–	–	900	900	–	–	–	–
	500 V - $\cos\phi = 0,75$	A	–	–	–	–	–	–	–	–	1100	1100	1200	1800
Switch disconnectors Utilization category AC2	3 x 220 V~	kW	5,2	7	9	14	23	29	37	72	150	150	150	150
Rated power of three-phase loads	3 x 380 V~	kW	9	12,5	15,5	24	39	50	63	125	260	260	260	260
	3 x 500 V~	kW	11,8	17	20	33	52	66	84	165	340	340	340	340
	3 x 660 V~	kW	15,5	22	27	43	69	86	110	210	400	400	400	400
	3 x 220 V~	kW	3	4,5	7,5	12,5	18,5	21	–	27,5	27,5	27,5	27,5	27,5
Switch disconnectors for motors Utilization category AC3, AC23	3 x 380 V~	kW	5	8	13	21	32	37	–	47	47	47	47	47
	3 x 500 V~	kW	6	11	17	27	42	48	–	62	62	62	62	62
	3 x 660 V~	kW	6	11	17	27	55	60	–	80	80	80	80	80
	3 x 220 V~	kW	–	–	–	–	–	–	27,5	27,5	27,5	27,5	27,5	27,5
Switch disconnectors for motors Utilization category AC23	3 x 380 V~	kW	–	–	–	–	–	–	47	47	47	47	47	47
	3 x 500 V~	kW	–	–	–	–	–	–	62	62	62	62	62	62
	3 x 660 V~	kW	–	–	–	–	–	–	80	80	80	80	80	80
	3 x 220 V~	kW	–	–	–	–	–	–	–	–	–	–	–	–
Switch disconnectors for motors, category of utility AC3, AC23 (30 connections/h). Rated power of one-phase (dipolar) motors.	110 V~	kW	0,8	1,3	2,1	3,6	5,3	6	–	–	–	–	–	–
	220 V~	kW	1,7	2,6	4,3	7,2	10,6	12,1	–	–	–	–	–	–
	380 V~	kW	2,8	4,6	7,5	12	18,5	21,1	–	–	–	–	–	–
Auxiliary switch disconnectors Utilization category AC14	110 V~	A	11	20	25	50	63	72	–	–	–	–	–	–
	220 V~	A	8	20	25	40	50	50	–	–	–	–	–	–
	380 V~	A	3,5	16	20	40	45	45	–	–	–	–	–	–
	660 V~	A	2,5	8	8,5	10	10	10	–	–	–	–	–	–
Type of operation		–	Continuous duty											

 1) - $\cos\phi = 0,65$

BREAKING CAPACITY FOR DIRECT CURRENT

Breaking capacity for direct current operation depends on current intensity, voltage and inductance.

Time constant $T = L/R$ represents inductance values in a current circuit.

$T = 1 \text{ ms}$ – active power or lightly inductive power predominates, for example resistance furnaces.

$T = 15 \text{ ms}$ – inductive power predominates, for example relay coils. For direct current and voltage above 60 V, switch contacts must be connected in parallel to obtain higher breaking capacity.

Table 131. Rated breaking capacity of one contact

Switch type	Rated breaking capacity of one contact											
	24 V		60 V		110 V		220 V		440 V		600 V	
	T = 1ms	T = 15ms	T = 1ms	T = 15ms	T = 1ms	T = 15ms	T = 1ms	T = 15ms	T = 1ms	T = 15ms	T = 1ms	T = 15ms
4G10	40	40	40	20	17	3	1,1	0,5	0,5	0,2	0,5	0,1
4G16	100	100	38	18	5,5	3	0,95	0,4	0,5	0,25	0,3	0,2
4G25	100	100	38	18	5,5	3	0,95	0,4	0,5	0,25	0,3	0,2
4G40	252	252	95	40	15	3,5	1,2	0,4	0,6	0,25	0,45	0,2
4G63	252	252	95	40	15	3,5	1,2	0,4	0,6	0,25	0,45	0,2
4G100	800	800	400	400	35	7,5	2,5	0,75	0,9	0,3	0,5	0,25

Table 136 shows a number of contacts which can be connected in series for rated making currents at specific constant voltages for category of utility DC 1.

Table 132. Number of contacts connected in series

Switch type	Number of contacts connected in series			
	110 V	220 V	440 V	600 V
4G10	1	3	6	8
4G16	2	4	6	9
4G25	2	4	6	9
4G40	2	3	6	9
4G63	2	4	6	9
4G100	2	3	6	–

DC1 - main noninductive or low voltage load

$T = 1 \text{ ms}$ breaking capacity $I = 1,5 I_g$

Note: Breaking capacity for a 4G25 switch with two contacts connected in series is 2A at 220V; $T = 15 \text{ ms}$. In table 137 the rated making current values (I_e) for category of utility DC 11 (according to EC 337-1, 337-1A) have been shown.

Table 133. Rated switching current

Switch type	Rated switching current I_e [A]					
	24 V	60 V	110 V	220 V	440 V	600 V
4G10	10	2	1	0,27	0,16	0,14
4G16	20	2,2	1	0,3	0,22	0,16
4G25	25	2,2	1	0,3	0,22	0,16
4G40	50	5	2	0,4	0,23	0,2
4G63	63	5	2	0,4	0,23	0,2

SWITCHING PROGRAMS

Switching program	Diagram number	Page	
Switch disconnectors with "0" (0-1) position			
1-pole	90	167	
2-pole	91		
3-pole	10		
multi-pole	92		
	100		
	528		
	659		
Switch disconnectors with quick-connecting contacts (0-1)			
with 30° contact lead	1-pole	270	167
	2-pole	271	
	3-pole	63	
with 30° contact lead on three contacts and 60° on one contact	4-pole	272	
with 30° contact lead on three contacts and 60° on two contacts	5-pole	273	
with 30° contact lead	6-pole	274	
Switches with "0" (1-0-2) position			
1-pole	51	168	
2-pole	52		
3-pole	53		
multi-pole	75		
	76		
	77		
	78		
	79		
	80		
81			
Switches for current transformers (1-2)			
	57	168	
Switches without "0" (1-2) position			
1-pole	54	169	
2-pole	55		
3-pole	56		
multi-pole	69		
	70		
	71		
	72		
	73		
	74		
62			
Multiposition switches with "0" (0-1-2...) position			
1-pole	3-position	107	170
	4-position	108	
	5-position	109	
	6-position	110	

Switching program	Diagram number	Page			
Multiposition switches with "0" (0-1-2...) position					
1-pole	7-position	111	170		
	8-position	112			
	9-position	113			
	10-position	114			
	11-position	115			
	12-position	116			
2-pole	3-position	123	171		
	4-position	124			
	5-position	125			
	6-position	126			
	7-position	127			
	8-position	128			
	9-position	129			
	10-position	130			
	11-position	131			
	12-position	132			
	3-pole	3-position		135	172
		4-position		136	
5-position		137			
6-position		138			
7-position		139			
8-position		140			
multi-pole		3-position	145	172	
		4-position	146		
	5-position	147			
	6-position	148			
	3-position	151			
	4-position	152			
	5-position	153			
	3-position	156			
	4-position	157			
	5-position	158			
1-pole	3-position	160	173		
	4-position	161			
	3-position	163			
	4-position	164			
	Multiposition switches without "0" position				
	1-pole	3-position		82	174
		4-position		83	
		5-position		84	
6-position		85			
7-position		101			
8-position		102			
9-position		103			
10-position		104			
11-position		105			
12-position		106			

Switching program	Diagram number	Page	
Multiposition switches without "0" position			
2-pole	3-position	86	
	4-position	87	
	5-position	88	
	6-position	89	
	7-position	117	
	8-position	118	
	9-position	119	
	10-position	120	
	11-position	121	
	12-position	122	
3-pole	3-position	93	
	4-position	94	
	5-position	95	
	6-position	96	
	7-position	133	
	8-position	134	
	3-position	141	
	4-position	142	
multi-pole	5-position	143	
	6-position	144	
	3-position	149	
	4-position	150	
	3-position	154	
	4-position	155	
	3-position	159	
	3-position	162	
	Switchgroups with "0" position		
	1-pole	2-group.	251
3-group.		254	
2-pole	2-group.	252	
	3-group.	255	
3-pole	2-group.	253	
	3-group.	256	
Serial switches			
1-pole		257	
2-pole		258	
3-pole		259	
Serial-parallel switches			
2-pole		260	
Measurement switches for voltage and current			
Ammeter switches			
phase measurement	L1-L2-L3	58	
phase measurement	0-1-2-3	97	
phase measurement with grounding	0-1-2-3	98	
Serial-parallel switches			
3 phase-to-phase voltages + phase voltage		60	

Switching program	Diagram number	Page	
Voltmeter switches without "0" position			
3 phase voltages	68	180	
3 phase-to-phase voltages	67		
3 phase-to-phase voltages + 3 phase voltages	66		
Switches with an automatic return to initial position			
switch with a function of left - right pushbuttons switch with "0" position (1-0-2) return to "0" from both sides	210	180	
1-pole	201		
2-pole	202		
3-pole	203		
Switches without "0" position			
1 normally closed contact + 1 normally open contact	204	181	
2 normally closed contacts + 2 normally open contacts	205		
3 normally closed contacts + 3 normally open contacts	206		
to control a contactor – 1 normally open contact (turn right) and 1 normally closed contact (turn left)	207		
1 normally open contact and 1 normally closed contact, when turning left and right	208		
2 normally open contacts and 2 normally closed contacts, when turning left and right	209		
Switch disconnectors for motor controlling, Star-delta switch disconnectors			
basic version	12		181
Y/Δ back from Y to 0	28		
with counter-current braking back from Y to 0	29		
as a voltage switch	30	182	
for operation with contactor	31		
bidirectional (left-right)	21		
Switch disconnectors in a Dahlander's system			
dipolar Δ-0-YY	13	182	
dipolar 0-Δ-YY	19		
dipolar bidirectional YY-Δ-0-Δ-YY	20		
dipolar and contactor controlling	32		
Switch disconnectors for two-winding motors			
0-1-2	22	183	
bidirectional	23		
to control the contactors	33		
Switch disconnectors for three-speed motors			
2 windings 0-Δ-YY-Y (with 3 speeds in a Dahlander's system)	34	184	
2 windings 0-Δ-YY-Y (1 and 2 speeds in a Dahlander's system)	35		
2 windings 0-Δ-YY-Y (2 and 3 speeds in a Dahlander's system)	36		
Reversing switches			
2-pole	24	184	
2-pole, return to "0" position	25		
3-pole	11		
3-pole, return to "0" position	26		
to control a contactor	27		
starting switches for 1-phase motors	15		

AN ORDER EXAMPLE

4G25 - 10 - U S5 R112

switch type determined according to the rated current, selection in accordance with table 1

diagram number specified in the switching program

version:
U- switch to be built-in
OU- switch to be mounted in a housing
PK- switch in a plastic case

special version, its symbol can be added to the description of type

knob and handle version and colour according to table 3

NOTES:

- every order on devices for rated current 100A requires arrangements with the manufacturer related to the technical details and delivery date.
- devices in PK housings can be made only for those switching programs which require not more than four segments (protection class IP55/IP65).
EXPRES SERVICE 24 h or 48 h - There is the ability to perform cam switches in 24 or 48 h (additional fee)

STANDARD CONNECTION DIAGRAMS

Diagram number	Number of poles	Rated switching current	Rated voltage	Number of packs	Symbol Article No.	Handle	Protection degree IP from the front	Maximum conductor cross-section [mm ²]	Installation
Switch disconnector with "0" (0-1) position									
	1	10	690	1	4G10-90-U 63-840390-011	R014	IP40	2 x 2,5	to be mounted behind the panel
	1	16	690	1	4G16-90-U 63-840390-021	R114	IP40	2 x 4	to be mounted behind the panel
	1	25	690	1	4G25-90-U 63-840390-031	R114	IP40	2 x 6	to be mounted behind the panel
	1	10	690	1	4G10-90-PK 63-840392-011	R014	IP55	2 x 2,5	in a housing
	1	25	690	1	4G10-90-PK IP65 63-840392-111	R114	IP65	2 x 6	in a housing
	1	16	690	1	4G16-90-PK 63-840392-021	R114	IP55	2 x 4	in a housing
	1	25	690	1	4G25-90-PK 63-840392-031	R114	IP55	2 x 6	in a housing
	2	10	690	1	4G10-91-U 63-840393-011	R014	IP40	2 x 2,5	to be mounted behind the panel
	2	16	690	1	4G16-91-U 63-840393-021	R114	IP40	2 x 4	to be mounted behind the panel
	2	10	690	1	4G10-91-PK 63-840395-011	R014	IP55	2 x 2,5	in a housing
	2	25	690	1	4G10-91-PK IP65 63-840395-111	R114	IP65	2 x 6	in a housing
	2	16	690	1	4G16-91-PK 63-840395-021	R114	IP55	2 x 4	in a housing
	2	25	690	1	4G25-91-PK 63-840395-031	R114	IP55	2 x 6	in a housing

* See dimensions on pages 185-188

Diagram number	Number of poles	Rated switching current	Rated voltage	Number of packs	Symbol Article No.	Handle	Protection degree IP from the front	Maximum conductor cross-section [mm ²]	Installation
Switch disconnector with "0" (0-1) position									
	3	10	690	2	4G10-10-U 63-840304-011	R014	IP40	2 x 2,5	to be mounted behind the panel
	3	16	690	2	4G16-10-U 63-840304-021	R114	IP40	2 x 4	to be mounted behind the panel
	3	25	690	2	4G25-10-U 63-840304-031	R114	IP40	2 x 6	to be mounted behind the panel
	3	40	690	2	4G40-10-U 63-840304-041	R214	IP40	2 x 10	to be mounted behind the panel
	3	63	690	2	4G63-10-U 63-840304-051	R214	IP40	2 x 10	to be mounted behind the panel
	3	80	690	2	4G80-10-U 63-840304-061	R214	IP40	25	to be mounted behind the panel
	3	10	690	2	4G10-10-PK 63-840306-011	R014	IP55	2 x 2,5	in a housing
	3	10	690	2	4G10-10-PK IP65 63-840306-111	R014	IP65	2 x 2,5	in a housing
	3	16	690	2	4G16-10-PK 63-840306-021	R114	IP55	2 x 4	in a housing
	3	25	690	2	4G25-10-PK 63-840306-031	R114	IP55	2 x 6	in a housing
	3	40	690	2	4G40-10-PK 63-840306-041	R214	IP55	2 x 10	in a housing
	3	63	690	2	4G63-10-PK 63-840306-051	R214	IP55	2 x 10	in a housing
	3	80	690	2	4G80-10-PK 63-840306-061	R214	IP55	25	in a housing
	4	10	690	2	4G10-92-U 63-840396-011	R014	IP40	2 x 2,5	to be mounted behind the panel
	4	16	690	2	4G16-92-U 63-840396-021	R114	IP40	2 x 4	to be mounted behind the panel
	4	25	690	2	4G25-92-U 63-840396-031	R114	IP40	2 x 6	to be mounted behind the panel
	4	40	690	2	4G40-92-U 63-840396-041	R214	IP40	2 x 10	to be mounted behind the panel
	4	63	690	2	4G63-92-U 63-840396-051	R214	IP40	2 x 10	to be mounted behind the panel
	4	80	690	2	4G80-92-U 63-840396-061	R214	IP40	25	to be mounted behind the panel
	4	10	690	2	4G10-92-PK 63-840398-011	R014	IP55	2 x 2,5	in a housing
	4	10	690	2	4G10-92-PK IP65 63-840398-111	R014	IP65	2 x 2,5	in a housing
	4	16	690	2	4G16-92-PK 63-840398-021	R114	IP55	2 x 4	in a housing
	4	25	690	2	4G25-92-PK 63-840398-031	R114	IP55	2 x 6	in a housing
	4	40	690	2	4G40-92-PK 63-840398-041	R214	IP55	2 x 10	in a housing
	4	63	690	2	4G63-92-PK 63-840398-051	R214	IP55	2 x 10	in a housing
	4	80	690	2	4G80-92-PK 63-840398-061	R214	IP55	25	in a housing

* See dimensions on pages 185-188

Diagram number	Number of poles	Rated switching current	Rated voltage	Number of packs	Symbol Article No.	Handle	Protection degree IP from the front	Maximum conductor cross-section [mm ²]	Installation
„Mains-unit” switch (1-0-2)									
	1	10	690	1	4G10-51-U 63-840338-011	R014	IP40	2 x 2,5	to be mounted behind the panel
	1	10	690	1	4G10-51-PK 63-840340-011	R014	IP55	2 x 2,5	in a housing
	1	10	690	1	4G10-51-PK IP65 63-840340-111	R014	IP65	2 x 2,5	in a housing
	2	10	690	2	4G10-52-U 63-840341-011	R014	IP40	2 x 2,5	to be mounted behind the panel
	„Rotation direction change” switch (L-O-P)								
	3	10	690	3	4G10-53-U 63-840343-011	R014	IP40	2 x 2,5	to be mounted behind the panel
	3	16	690	3	4G16-53-U 63-840343-021	R114	IP40	2 x 4	to be mounted behind the panel
	3	25	690	3	4G25-53-U 63-840343-031	R114	IP40	2 x 6	to be mounted behind the panel
	3	40	690	3	4G40-53-U 63-840343-041	R214	IP40	2 x 10	to be mounted behind the panel
	3	63	690	3	4G63-53-U 63-840343-051	R214	IP40	2 x 10	to be mounted behind the panel
	3	80	690	3	4G80-53-U 63-840343-061	R214	IP40	25	to be mounted behind the panel
	3	10	690	3	4G10-53-PK 63-840345-011	R014	IP55	2 x 2,5	in a housing
	3	10	690	3	4G10-53-PK IP65 63-840345-111	R014	IP65	2 x 2,5	in a housing
	3	16	690	3	4G16-53-PK 63-840345-021	R114	IP55	2 x 4	in a housing
	3	25	690	3	4G25-53-PK 63-840345-031	R114	IP55	2 x 6	in a housing
	3	40	690	3	4G40-53-PK 63-840345-041	R214	IP55	2 x 10	in a housing
	3	63	690	3	4G63-53-PK 63-840345-051	R214	IP55	2 x 10	in a housing
	3	80	690	3	4G80-53-PK 63-840345-061	R214	IP55	25	in a housing

* See dimensions on pages 185-188

Diagram number	Number of poles	Rated switching current	Rated voltage	Number of packs	Symbol Article No.	Handle	Protection degree IP from the front	Maximum conductor cross-section [mm ²]	Installation
----------------	-----------------	-------------------------	---------------	-----------------	--------------------	--------	-------------------------------------	--	--------------

„Rotation direction change” switch (L-O-P)

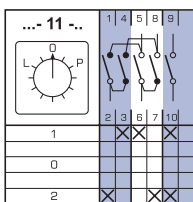

3	10	690	3	4G10-11-PK 63-840309-011	R014	IP55	2 x 2,5	in a housing
3	10	690	3	4G10-11-PK IP65 63-840309-111	R014	IP65	2 x 2,5	in a housing
3	16	690	3	4G16-11-PK 63-840309-021	R114	IP55	2 x 4	in a housing
3	25	690	3	4G25-11-PK 63-840309-031	R114	IP55	2 x 6	in a housing
3	40	690	3	4G40-11-PK 63-840309-041	R214	IP55	2 x 10	in a housing
3	63	690	3	4G63-11-PK 63-840309-051	R214	IP55	2 x 10	in a housing
3	80	690	3	4G80-11-PK 63-840309-06	R214	IP55	25	in a housing

„Star-delta” (Y-O-Δ) motor control switch

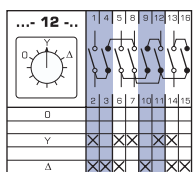

3	10	690	4	4G10-12-U 63-840310-011	R014	IP40	2 x 2,5	to be mounted behind the panel
3	16	690	4	4G16-12-U 63-840310-021	R114	IP40	2 x 4	to be mounted behind the panel
3	25	690	4	4G25-12-U 63-840310-031	R114	IP40	2 x 6	to be mounted behind the panel
3	40	690	4	4G40-12-U 63-840310-041	R214	IP40	2 x 10	to be mounted behind the panel
3	63	690	4	4G63-12-U 63-840310-051	R214	IP40	2 x 10	to be mounted behind the panel
3	80	690	4	4G80-12-U 63-840310-061	R214	IP40	25	to be mounted behind the panel
3	10	690	4	4G10-12-PK 63-840591-011	R014	IP55	2 x 2,5	in a housing
3	10	690	4	4G10-12-PK IP65 63-840591-111	R014	IP65	2 x 2,5	in a housing
3	16	690	4	4G16-12-PK 63-840591-021	R114	IP55	2 x 4	in a housing
3	25	690	4	4G25-12-PK 63-840591-031	R114	IP55	2 x 6	in a housing
3	40	690	4	4G40-12-PK 63-840591-041	R214	IP55	2 x 10	in a housing
3	63	690	4	4G63-12-PK 63-840591-051	R214	IP55	2 x 10	in a housing
3	80	690	4	4G80-12-PK 63-840591-061	R214	IP55	25	in a housing

Voltmeter switch (L3L1, L2L3, L1L2 - 0 - L1N, L2N, L3N)

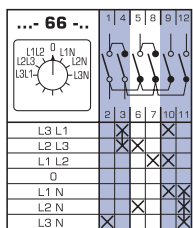

4	10	690	3	4G10-66-U 63-840360-011	R014	IP40	2 x 2,5	to be mounted behind the panel
---	----	-----	---	----------------------------	------	------	---------	--------------------------------

Switch for forklift trucks(1-0-2)

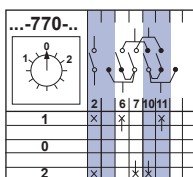

5	80	690	6	4G80-770-U 63-841838-061	R214	IP40	25	to be mounted behind the panel
---	----	-----	---	-----------------------------	------	------	----	--------------------------------

the contact (terminal 1-2) should be switched on in the control circuit coil of the contactor relay

* See dimensions on pages 185-188

Diagram number	Number of poles	Rated switching current	Rated voltage	Number of packs	Symbol Article No.	Handle	Protection degree IP from the front	Maximum conductor cross-section [mm ²]	Installation
Main (emergency) switch connectors									
	3	16	690	2	4G16-10-PK S6 63-241669-021	R114	IP55	2 x 4	in a housing
	3	16	690	2	4G16-10-OU S8 S25 63-241670-021	R114	IP40	2 x 4	mounting plate
	3	16	690	2	4G16-10-U S25 63-241671-021	R114	IP40	2 x 4	to be mounted behind the panel
	3	25	690	2	4G25-10-OU S8 S25 63-241672-031	R114	IP40	2 x 6	mounting plate
	3	25	690	2	4G25-10-PK S6 63-241673-031	R114	IP55	2 x 6	in a housing
	3	25	690	2	4G25-10-U S25 63-241674-031	R114	IP40	2 x 6	to be mounted behind the panel
	3	40	690	2	4G40-10-OU S8 S25 63-241675-041	R214	IP40	2 x 10	mounting plate
	3	40	690	2	4G40-10-PK S6 63-241676-041	R214	IP55	2 x 10	in a housing
	3	40	690	2	4G40-10-U S25 63-241677-041	R214	IP40	2 x 10	to be mounted behind the panel
	3	63	690	2	4G63-10-U S25 63-241678-051	R214	IP40	2 x 10	to be mounted behind the panel
3	80	690	2	4G80-10-U S6 63-241858-061	R214	IP40	25	to be mounted behind the panel	
Switches (1-2)									
	1	10	690	1	4G10-54-U 63-840346-011	R014	IP40	2 x 2,5	to be mounted behind the panel
	1	10	690	1	4G10-54-PK 63-840347-011	R014	IP55	2 x 2,5	in a housing
	1	10	690	1	4G10-54-PK IP65 63-840347-111	R014	IP65	2 x 2,5	in a housing
	2	10	690	2	4G10-55-U 63-840348-011	R014	IP40	2 x 2,5	to be mounted behind the panel
	2	10	690	2	4G10-55-PK 63-840350-011	R014	IP55	2 x 2,5	in a housing
	2	10	690	2	4G10-55-PK IP65 63-840350-111	R014	IP65	2 x 2,5	in a housing
	3	10	690	3	4G10-56-PK konfigurator	R014	IP40	2 x 2,5	in a housing
	4	10	690	4	4G10-69-U 63-840367-011	R014	IP40	2 x 2,5	to be mounted behind the panel

* Special versions S6 i S8 see on pages 190, S25 see on page 195
 * See dimensions on pages 185-188

SWITCHING PROGRAMS

Switch disconnecter with "0" (0-1) position

Table 134.

Switching program	Diagram number
1-pole	90
2-pole	91
3-pole	10
multi-pole	92
	99
	100
	528
	659

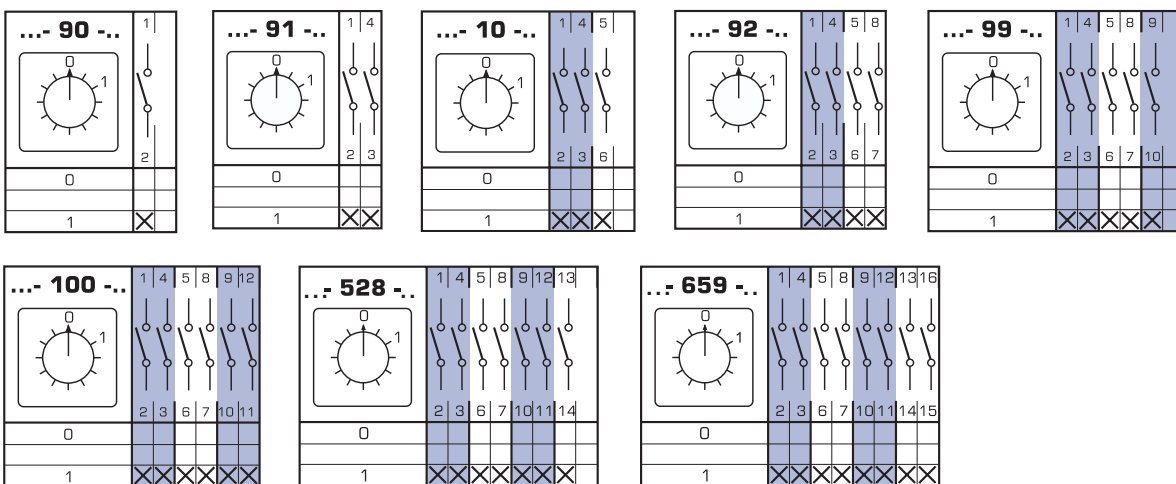

Switch disconnectors with quick-connecting contacts (0-1)

Table 135.

Switching program	Diagram number
with 30° contact lead 30°	1-pole 270
with 30° contact lead 30°	2-pole 271
with 30° contact lead 30°	3-pole 63
with 30° contact lead on three contacts and 60° on one contact	4-pole 272
with 30° contact lead on three contacts and 60° on two contacts	5-bpole 273
with 30° contact lead 30°	6-pole 274

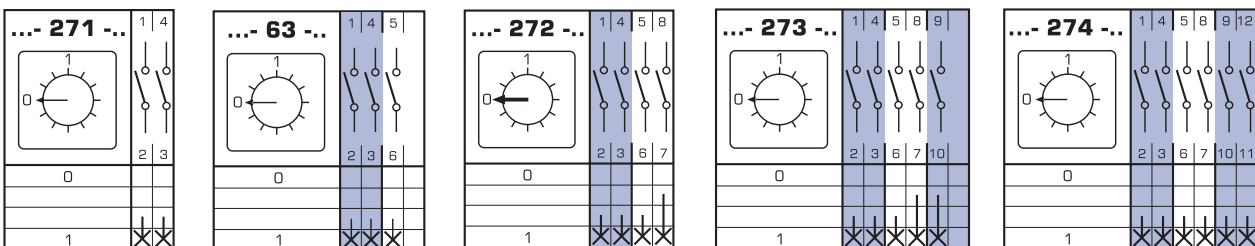
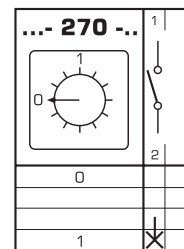

* See dimensions on pages 185-188

Switches with "0"(1-0-2) position

Switches for current transformers (1-2)

Table 136.

Switching program	Diagram number
1-pole	51
2-pole	52
3-pole	53
multi-pole	75
	76
	77
	78
	79
	80
	81

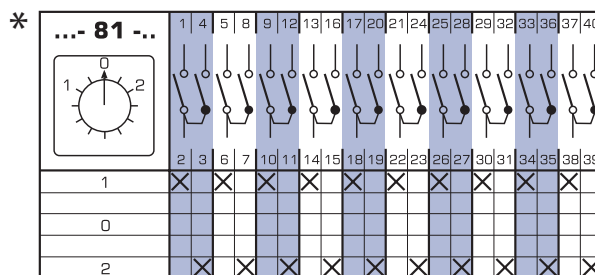
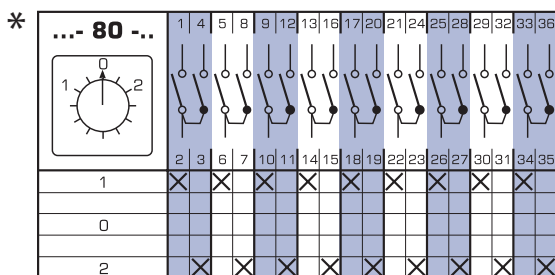
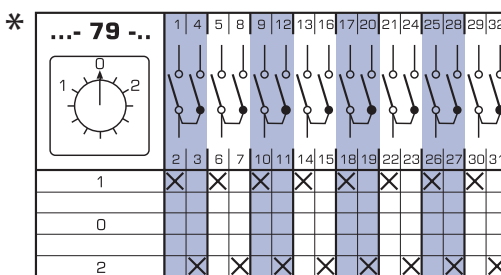
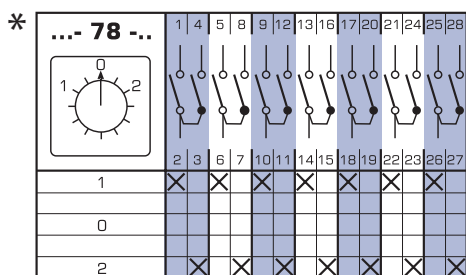
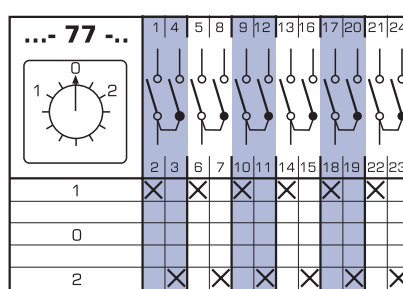
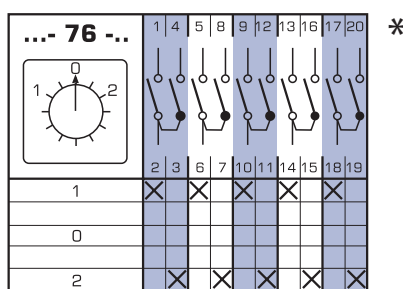
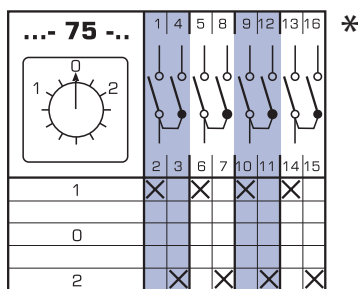
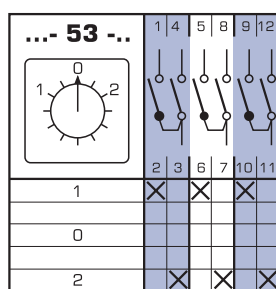
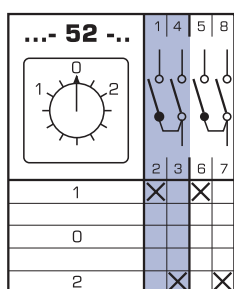
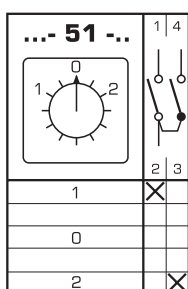
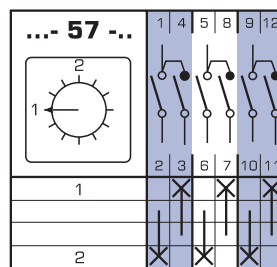

* Only in versions U, OU

* See dimensions on pages 185-188

SWITCHES WITHOUT "0"(1-2) POSITION

Table 137.

Switching program	Diagram number
1-pole	54
2-pole	55
3-pole	56
multi-pole	69
	70
	71
	72
	73
	74
	62

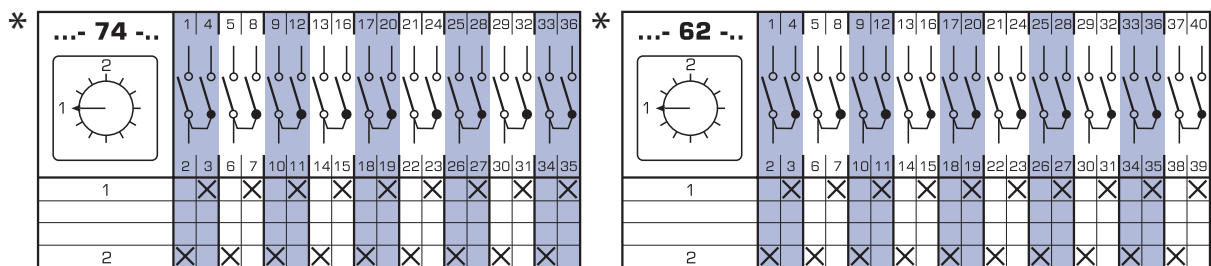
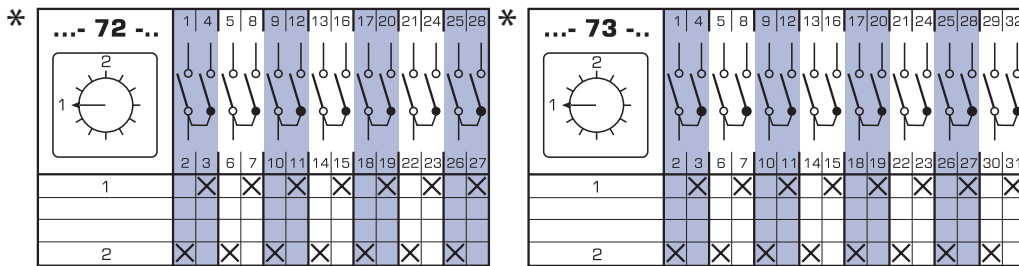
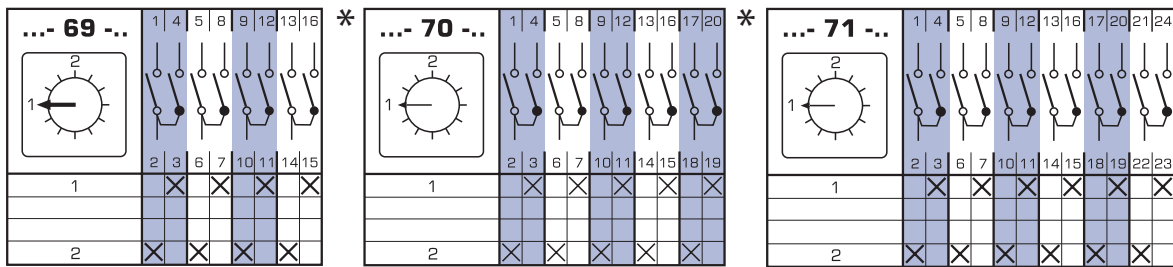
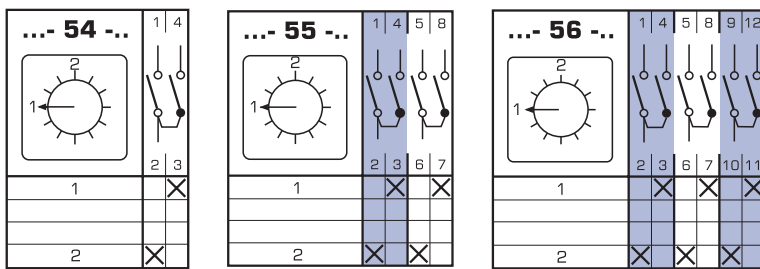

* Only in versions U, OU
* See dimensions on pages 185-188

Multiposition switches with "0" (0-1-2...) position

Table 138.

Switching program		Diagram number	
1-pole	3-position	107	
	4-position	108	
	5-position	109	
	6-position	110	
	7-position	111	
	8-position	112	
	9-position	113	
	10-position	114	
	11-position	115	
	12-position	116	
	2-pole	3-position	123
		4-position	124
5-position		125	
6-position		126	
7-position		127	
8-position		128	
9-position		129	
10-position		130	
11-position		131	
12-position		132	
3-pole	3-position	135	
	4-position	136	
	5-position	137	
	6-position	138	
	7-position	139	
	8-position	140	
	multi-pole	3-position	145
		4-position	146
5-position		147	
6-position		148	
3-position		151	
4-position		152	
5-position		153	
3-position		156	
4-position		157	
5-position		158	
3-position		160	
4-position		161	
3-position		163	
4-position		164	

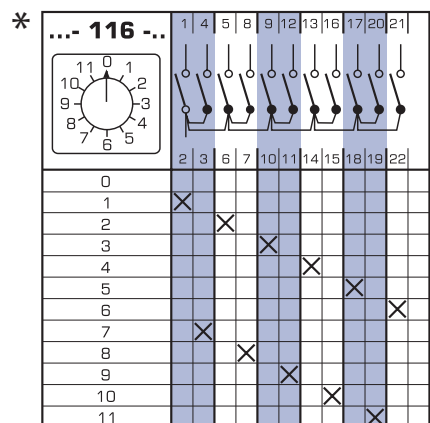
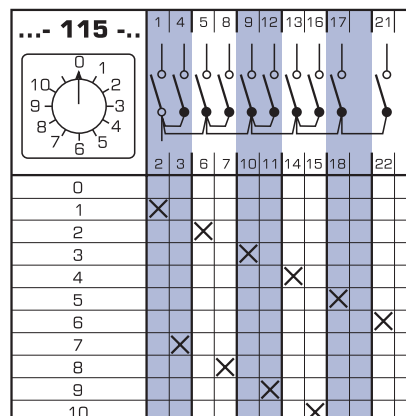
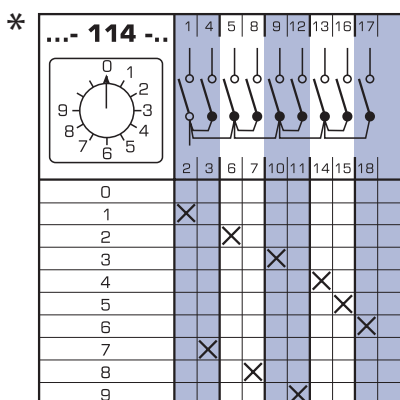
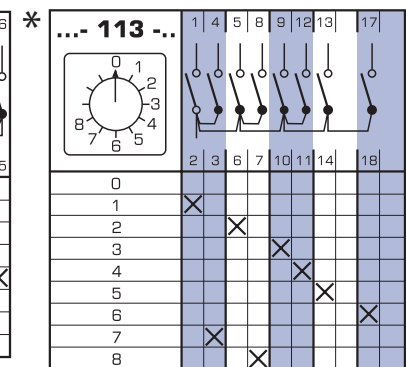
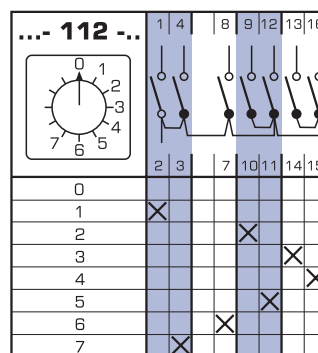
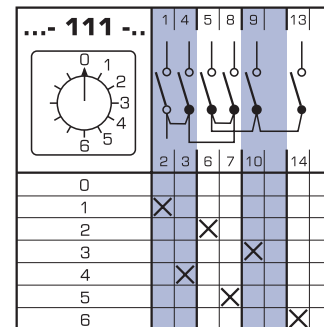
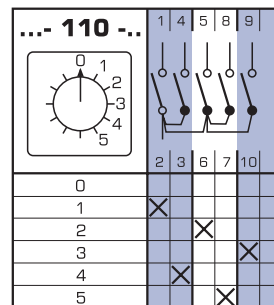
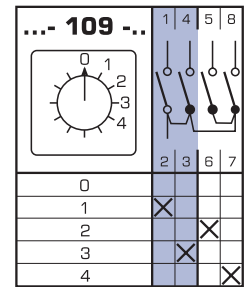
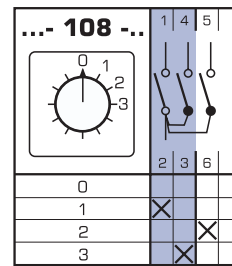
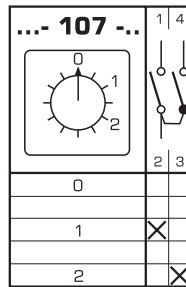

* Only in versions U, OU
 * See dimensions on pages 185-188

Multiposition switches with "0" (0-1-2...) position

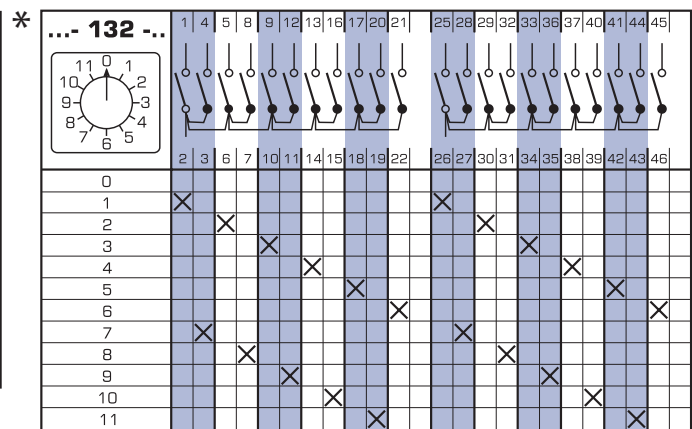
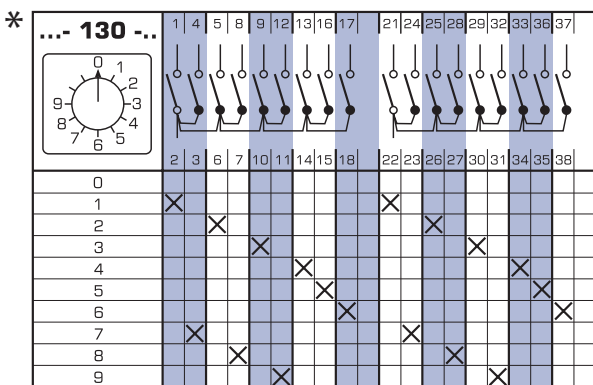
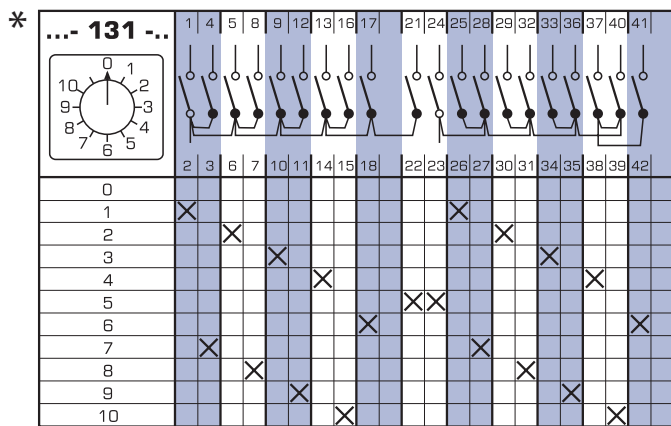
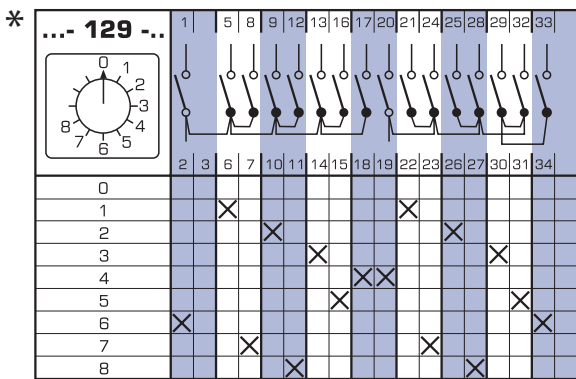
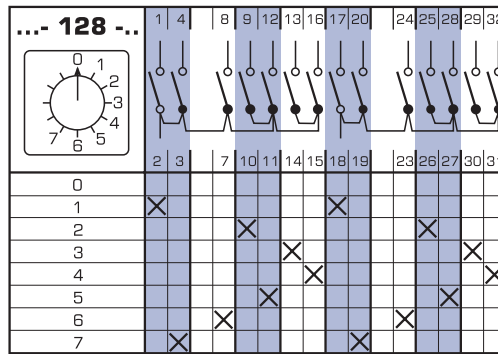
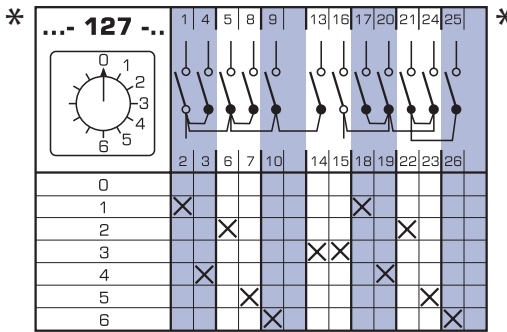
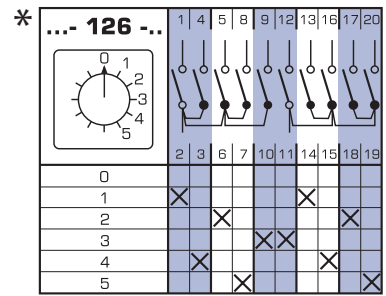
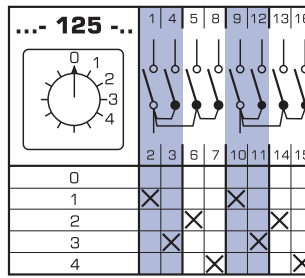
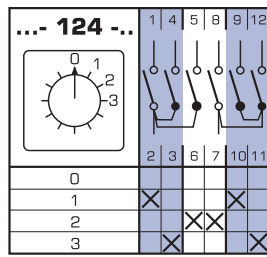
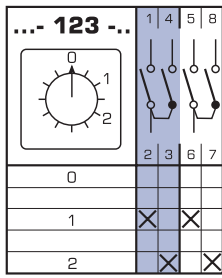

* Only in versions U, OU
* See dimensions on pages 185-188

Multiposition switches with "0" (0-1-2...) position

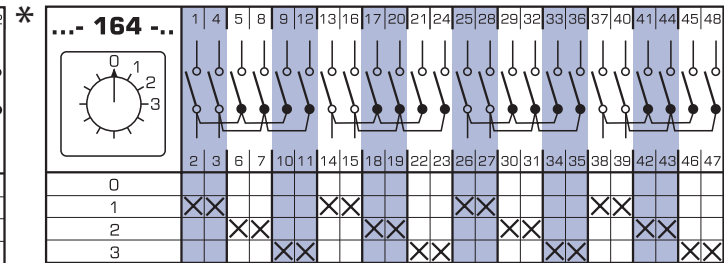
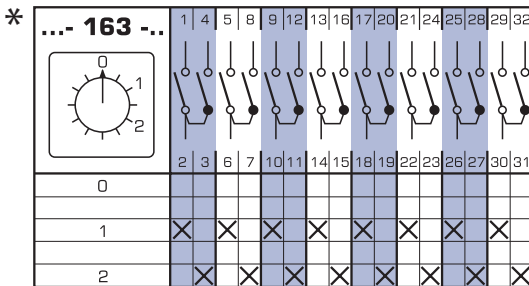
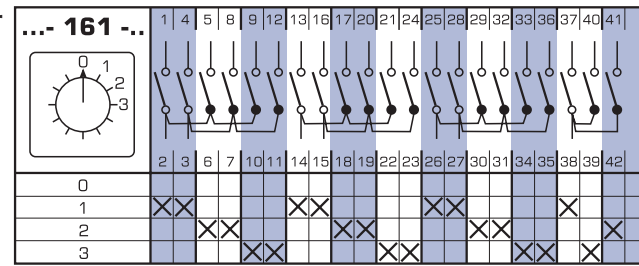
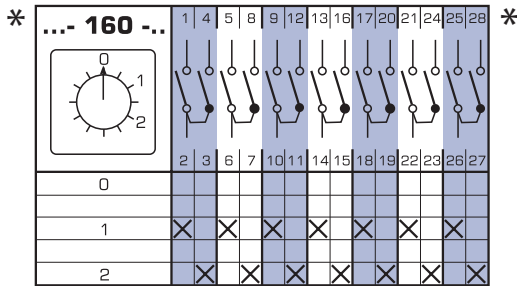
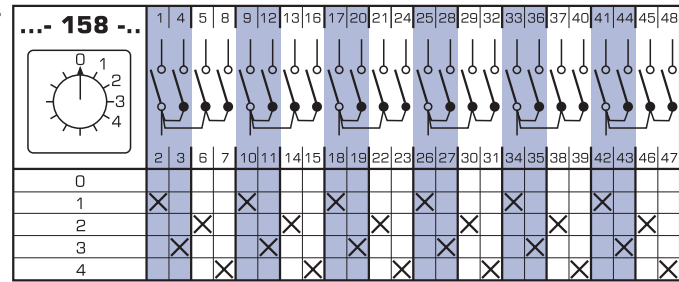
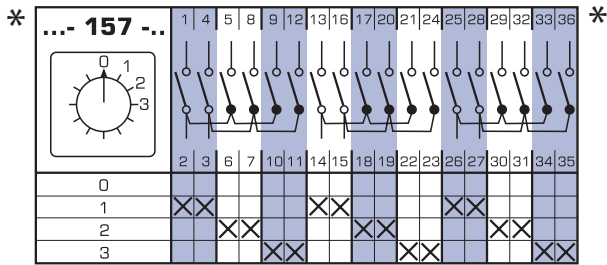
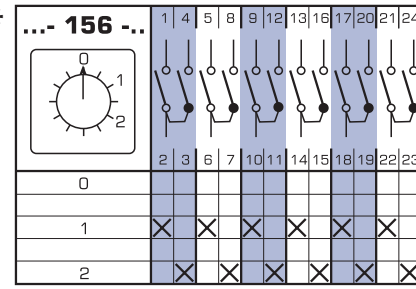
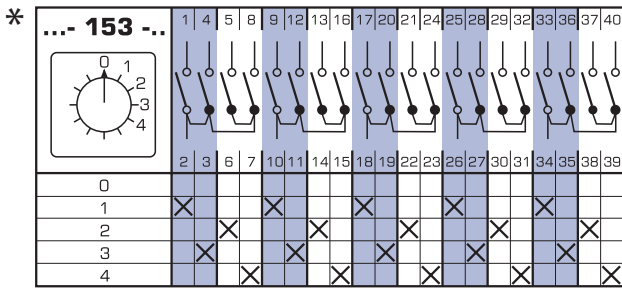

* Only in versions U, OU
 * See dimensions on pages 185-188

Multiposition switches without "0" position

Table 139.

Switching program	Diagram number		
1-pole	3-position	82	
	4-position	83	
	5-position	84	
	6-position	85	
	7-position	101	
	8-position	102	
	9-position	103	
	10-position	104	
	11-position	105	
	12-position	106	
	2-pole	3-position	86
		4-position	87
5-position		88	
6-position		89	
7-position		117	
8-position		118	
9-position		119	
10-position		120	
11-position		121	
12-position		122	
3-pole		3-position	93
		4-position	94
	5-position	95	
	6-position	96	
	7-position	133	
	8-position	134	
	multi-pole	3-position	141
		4-position	142
5-position		143	
6-position		144	
3-position		149	
4-position		150	
3-position		154	
4-position		155	
3-position		159	
3-position		162	

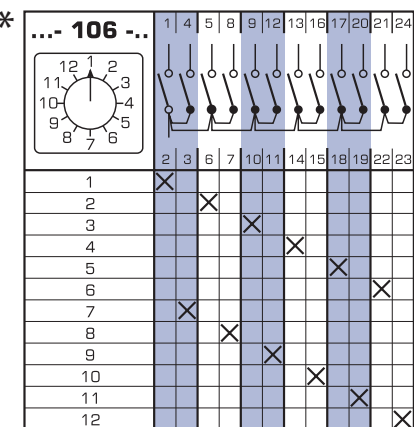
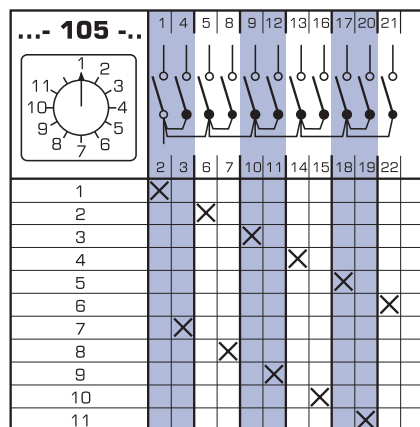
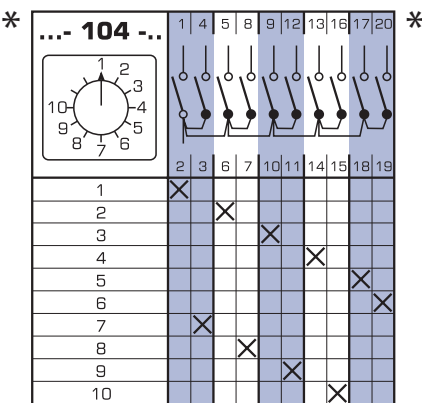
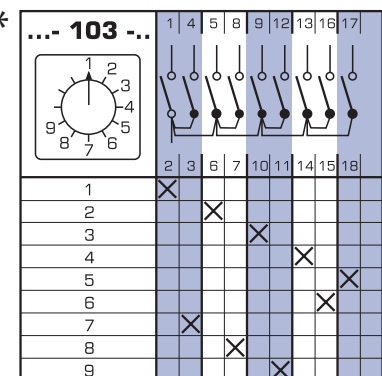
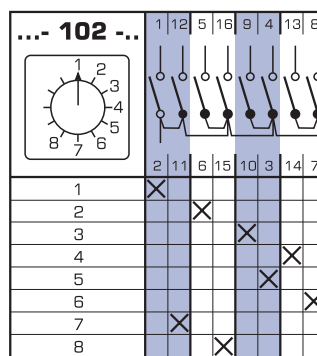
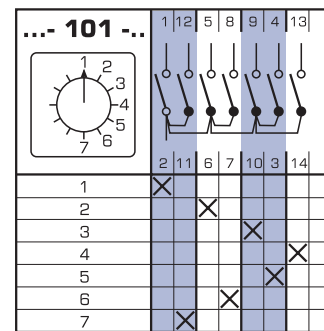
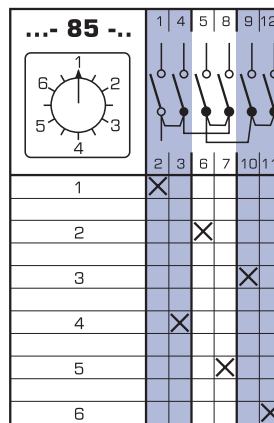
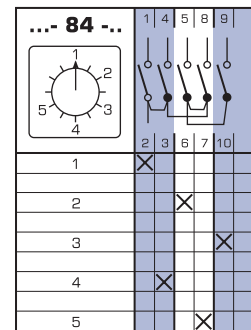
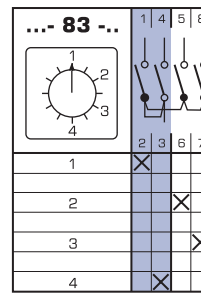
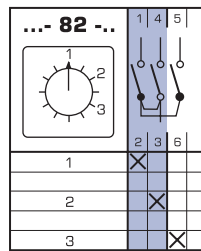

* Only in versions U, OU
 * See dimensions on pages 185-188

Multiposition switches without "0" position

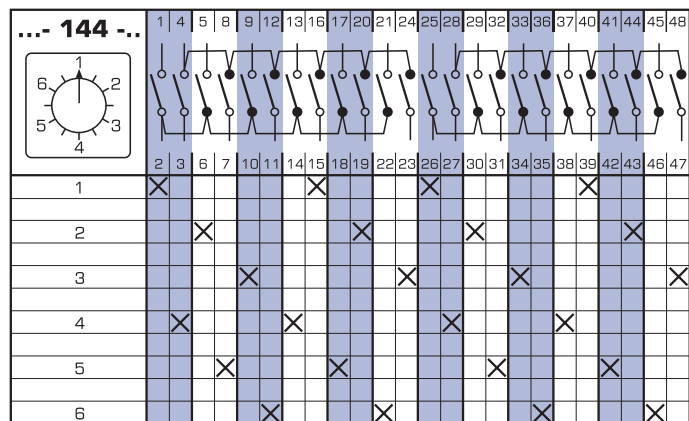
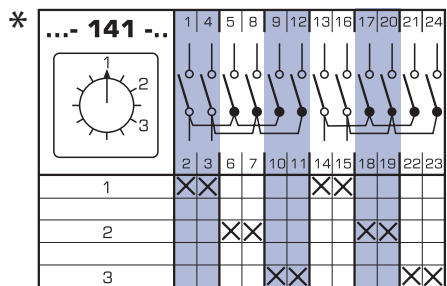
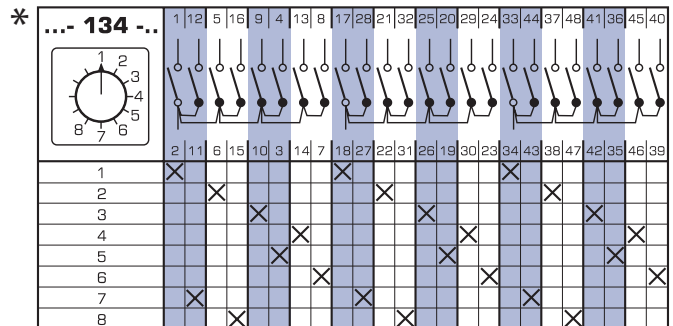
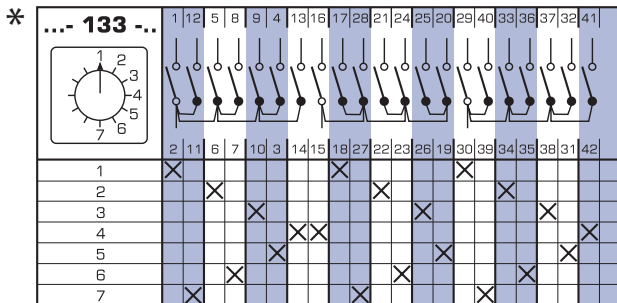
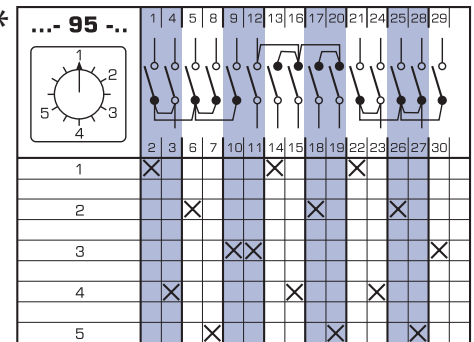
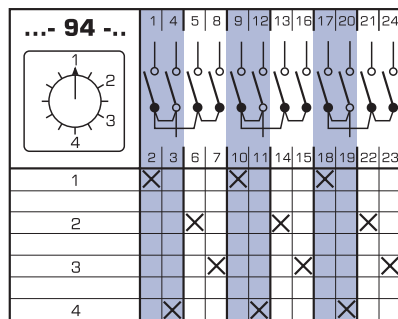
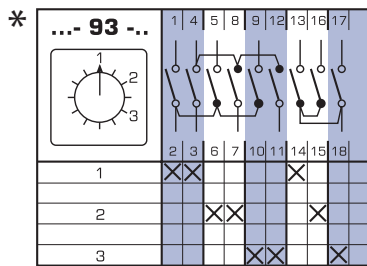
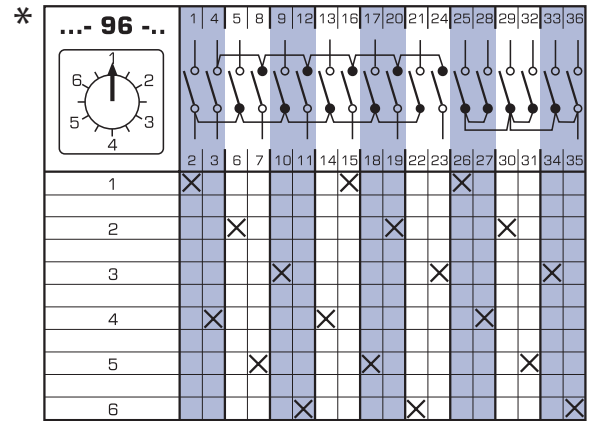
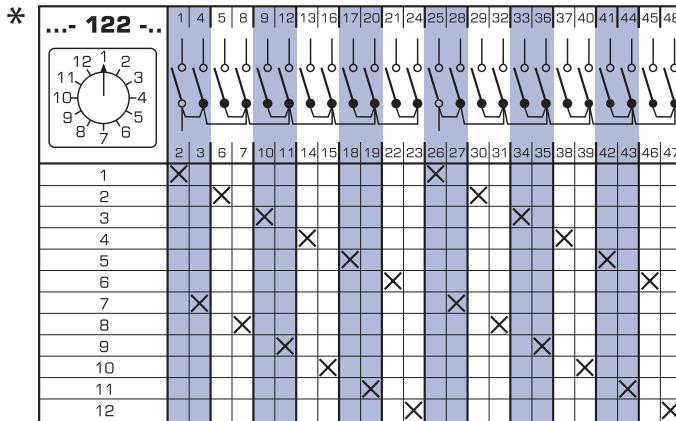

* Only in versions U, OU
* See dimensions on pages 185-188

Multiposition switches without "0" position

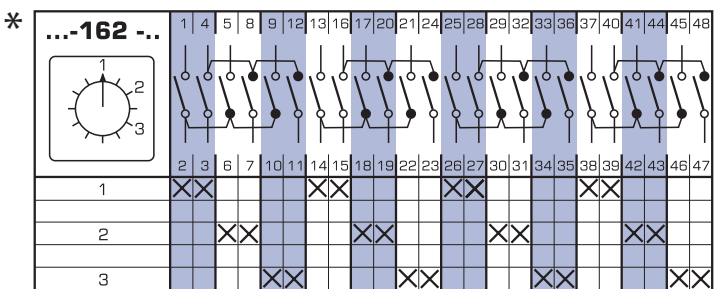
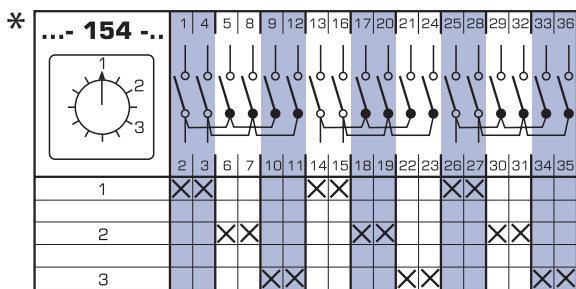
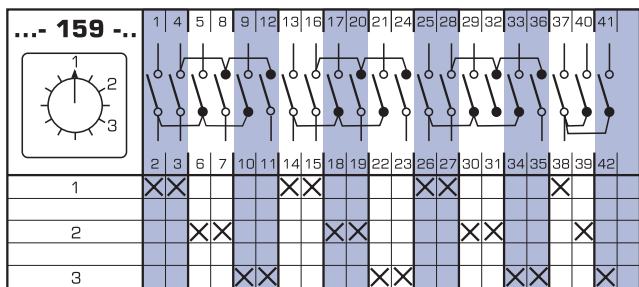
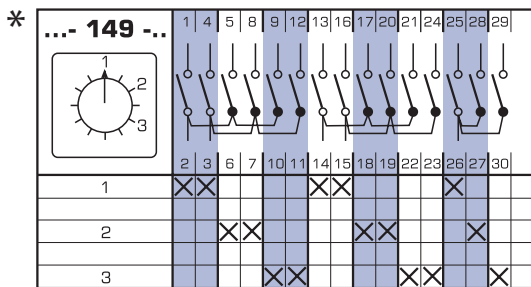
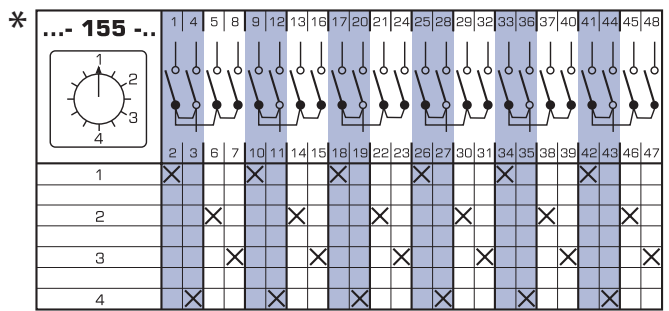
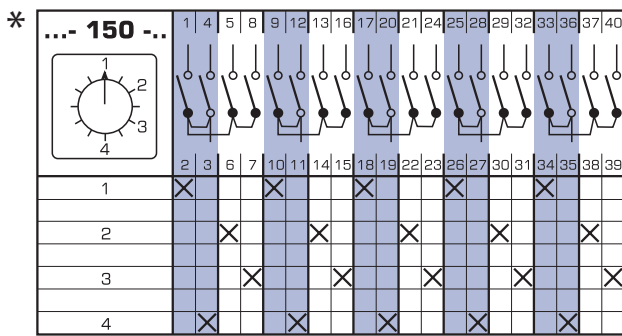
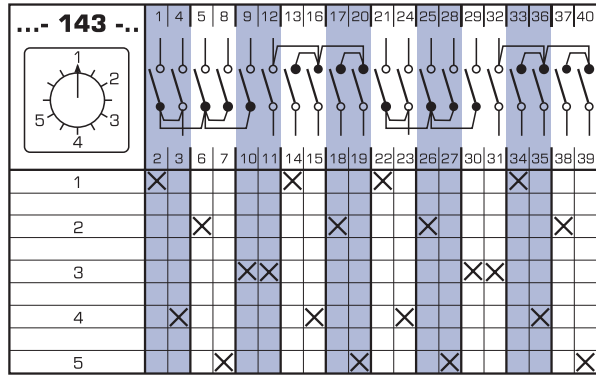
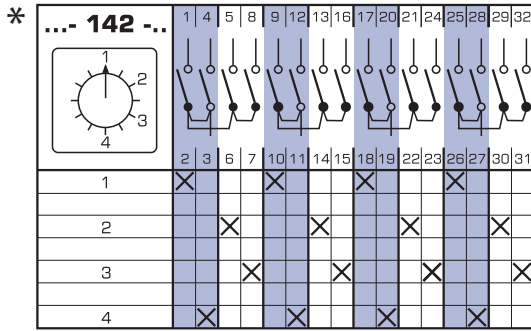

* Only in versions U, OU
 * See dimensions on pages 185-188

Switchgroups with "0" position

Table 140.

Switching program		Diagram number
1-pole	2-group	251
	3-group	254
2-pole	2-group	252
	3-group	255
3-pole	2-group	253
	3-group	256

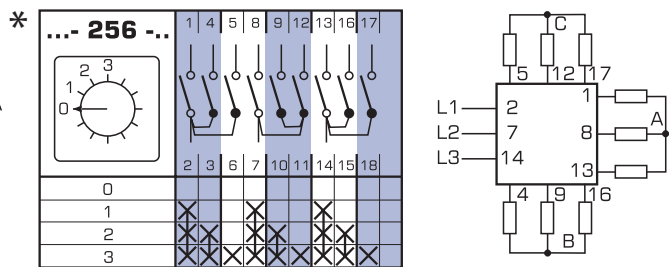
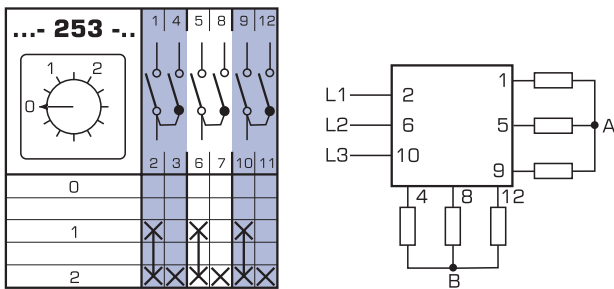
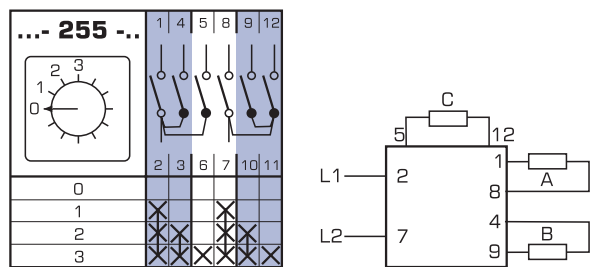
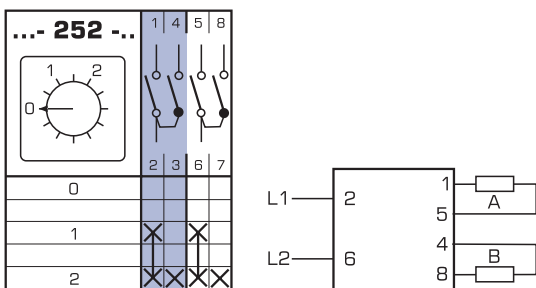
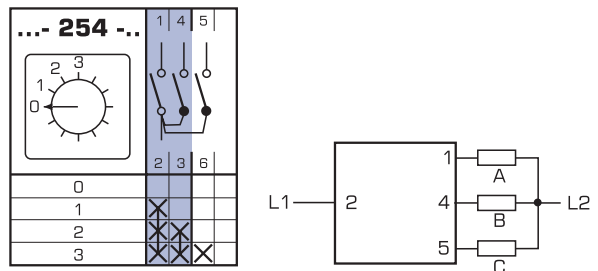
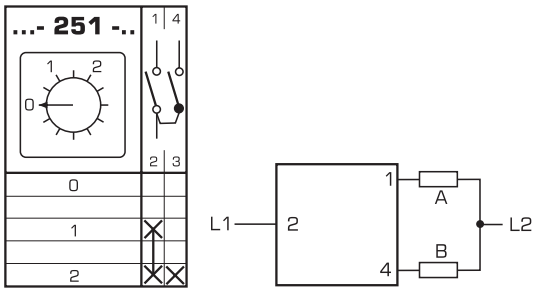

Serial switches

Table 141.

Switching program	Diagram number
1-pole	257
2-pole	258
3-pole	259

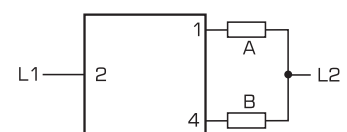
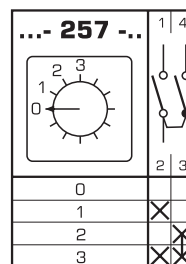

* Only in versions U, OU

* See dimensions on pages 185-188

Serial switches

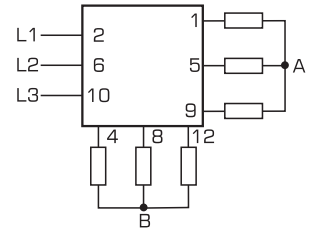
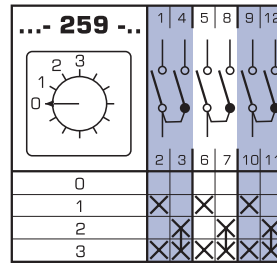
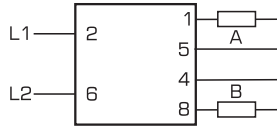
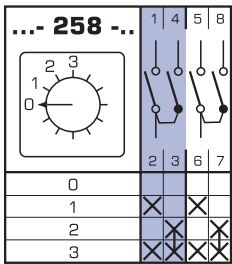

Serial-parallel switches

Table 142.

Switching program	Diagram number
2-pole	260

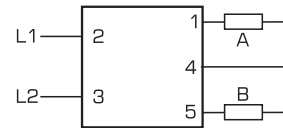
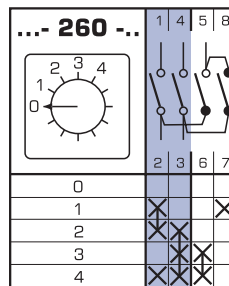

MEASUREMENT SWITCHES FOR VOLTAGE AND CURRENT

Ammeter switches

Table 143.

Switching program	Diagram number
phase measurement	L1-L2-L3 58
phase measurement	0-1-2-3 97
phase measurement with grounding	0-1-2-3 98

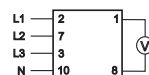
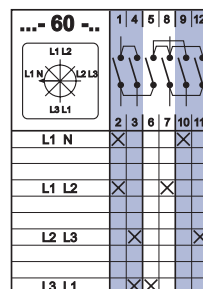
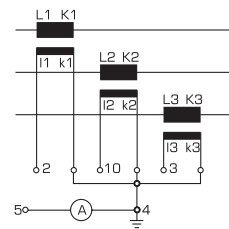
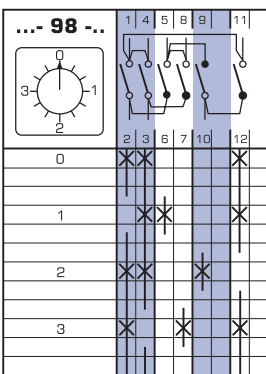
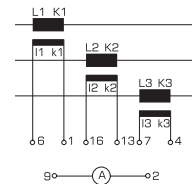
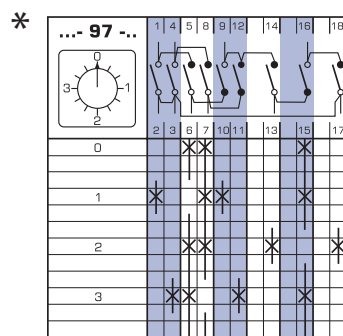
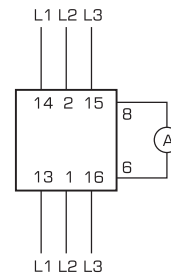
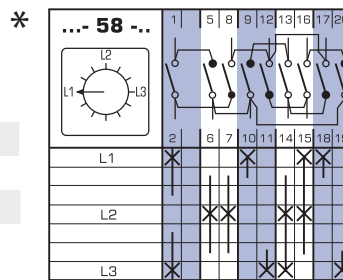

* Only in versions U, OU
* See dimensions on pages 185-188

MEASUREMENT SWITCHES FOR VOLTAGE AND CURRENT

Measurement switches for voltage and current, voltmeter switches without "0" position

Table 144.

Switching program	Diagram number
3 phase voltages	68
3 phase-to-phase voltages	67
3 phase-to-phase voltages+ phase voltage	66

...- 66 -..

L3 L1					
L2 L3	X	X			
L1 L2			X	X	
0					
L1 N					X
L2 N		X			X
L3 N	X				X

...- 67 -..

0					
L1 L2	X	X			
L2 L3			X	X	
L3 L1					X

...- 68 -..

0					
L1 N					X
L2 N		X			X
L3 N	X				X

SWITCHES WITH SELF-RELING BACK TO THE OUTPUT POSITION

Switch with "0" position (1-0-2), return to "0" from both sides

Table 145.

Switching program	Diagram number
switches with automatic return to initial position, switch with function of left - right pushbuttons	210
switch with "0" position (1-0-2) return to "0" from both sides	
1-pole	201
2-pole	202
3-pole	203

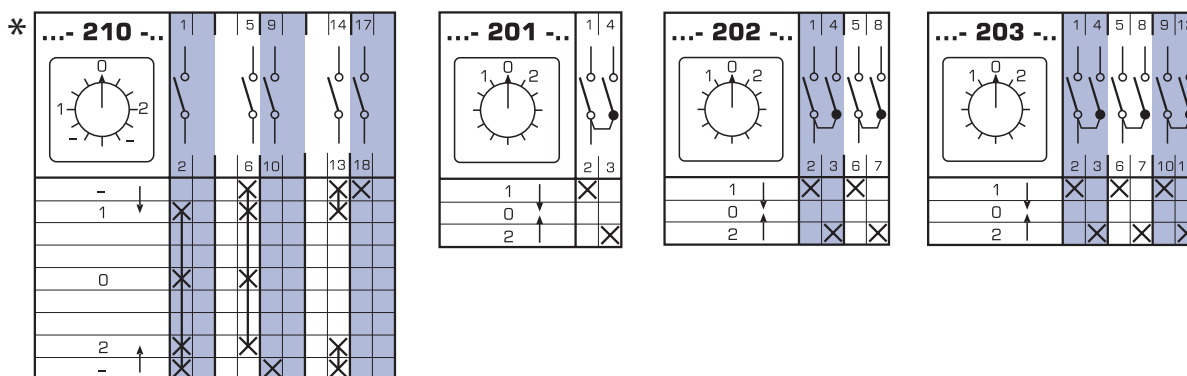

* Only in versions U, OU

* See dimensions on pages 185-188

SWITCHES WITH AUTOMATIC RETURN TO INITIAL POSITION

Switches without "0" (0-2) position

Table 146.

Switching program	Diagram number
1 normally closed contact + 1 normally open contact	204
2 normally closed contacts + 2 normally open contacts	205
3 normally closed contacts + 3 normally open contacts	206
to control a contactor – 1 normally open contact (turn right) and 1 normally closed contact (turn left)	207
1 normally open contact and 1 normally closed contact, when turning left and right	208
2 normally open contacts and 2 normally closed contacts, when turning left and right	209

SWITCH DISCONNECTORS FOR MOTOR CONTROLLING

Star-delta switch disconnectors

Table 147.

Switching program	Diagram number
basic version	12
Y/ Δ back from Y to 0	28
with counter-current braking back from Y to 0	29
as a voltage switch	30
for operation with contactor	31
bidirectional (left-right)	21

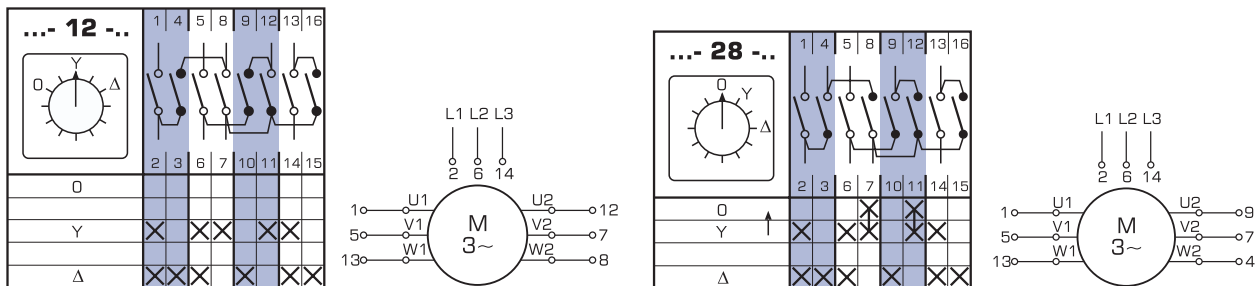

* See dimensions on pages 185-188

Star-delta switch disconnectors

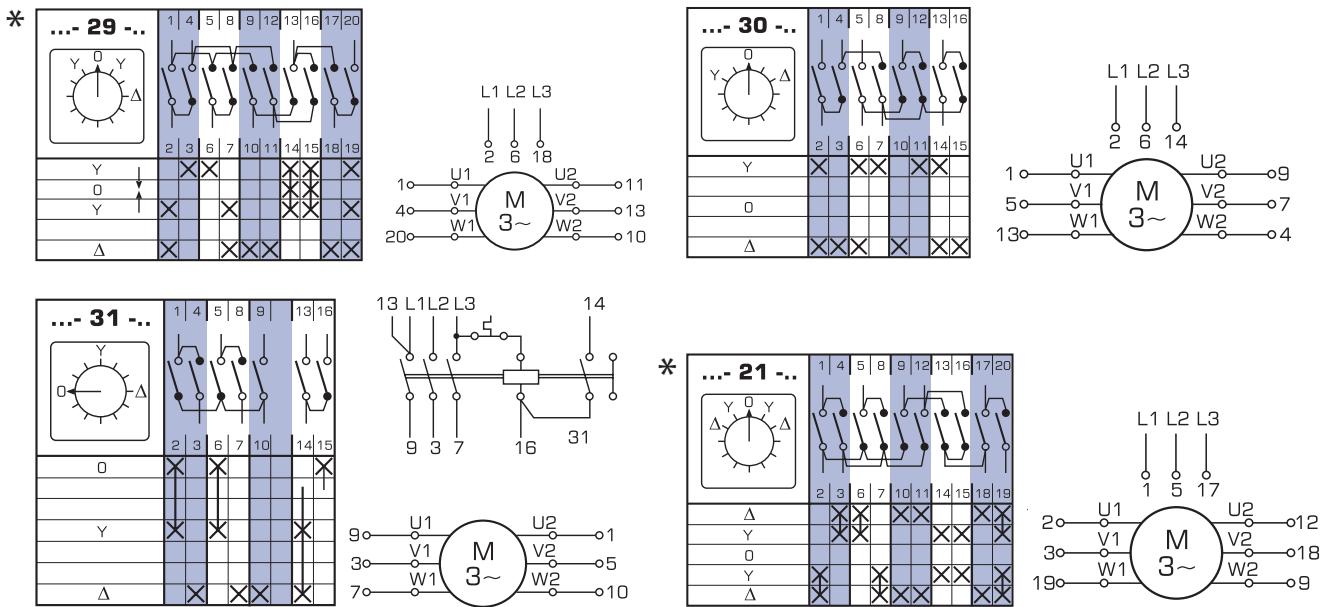

* Only in versions U, OU

Switch disconnectors in a Dahlander's system

Table 148.

Switching program	Diagram number
Switch disconnectors for motor controlling, switch disconnectors in a Dahlander's system dipolar Δ-0-YY	13
Dipolar 0-Δ-YY	19
Dipolar bidirectional YY-Δ-0-Δ-YY	20
Dipolar and contactor controlling	32

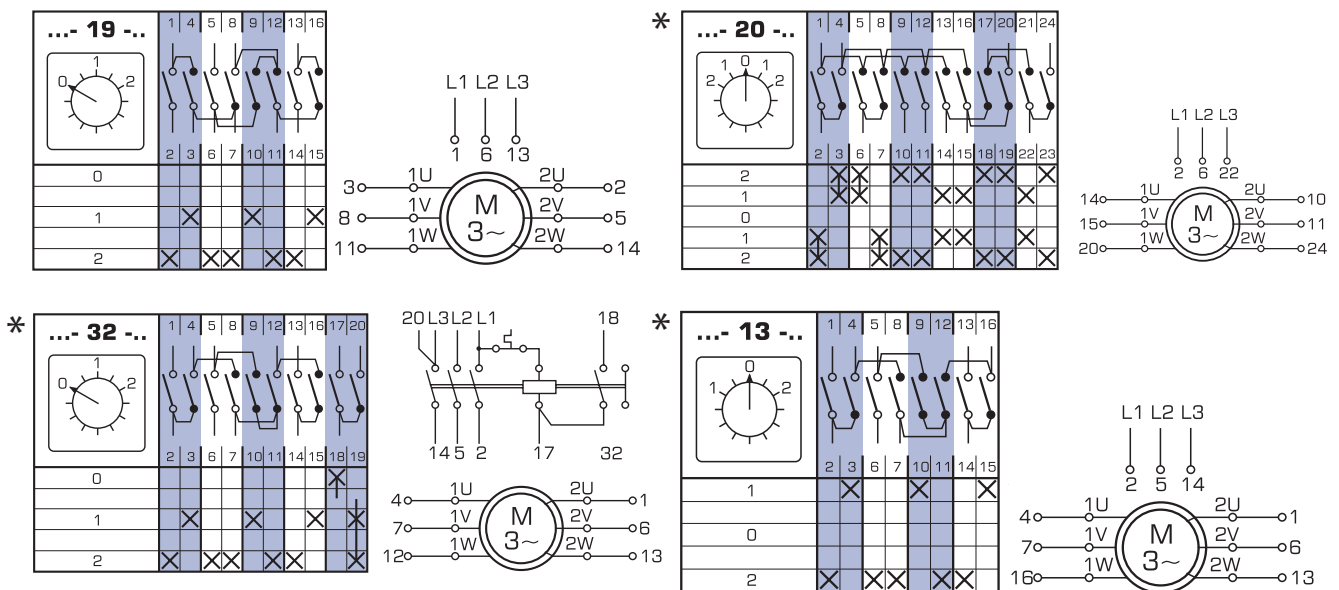

* Only in versions U, OU

* See dimensions on pages 185-188

SWITCH DISCONNECTORS FOR MOTOR CONTROLLING

Switch disconnectors for two-winding motors

Table 149.

Switching program	Diagram number
0-1-2	22
bidirectional to control the contactors	23
	33

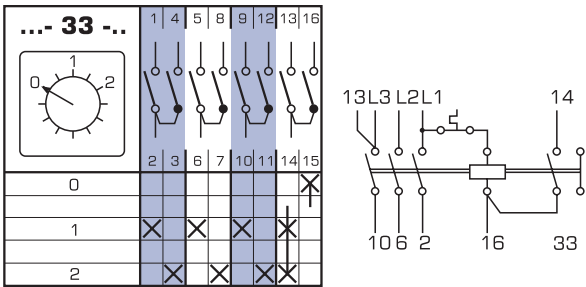
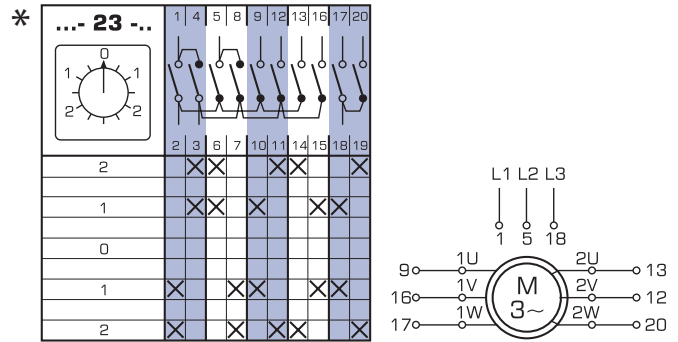
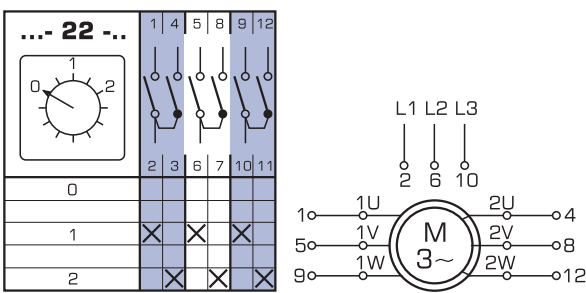

* Only in versions U, OU

* See dimensions on pages 185-188

Switch disconnectors for three-speed motors

Table 150.

Switching program	Diagram number
2 windings 0-Δ-Y-YY (with 3 speeds in a Dahlander's system)	34
2 windings 0-Δ-YY-Y (1 and 2 speeds in a Dahlander's system)	35
2 windings 0-Y-Δ-YY (2 and 3 speeds in a Dahlander's system)	36

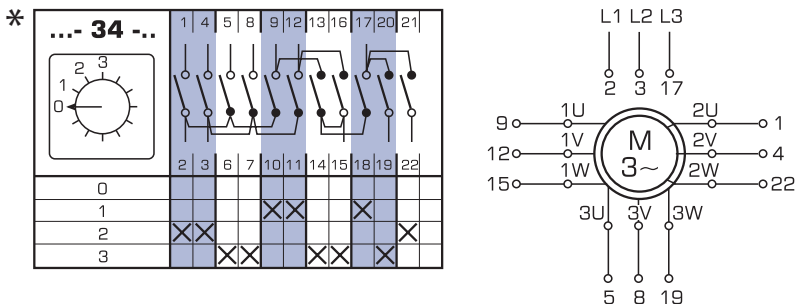

* Only in versions U, OU

* See dimensions on pages 185-188

Switch disconnectors for three-speed motors

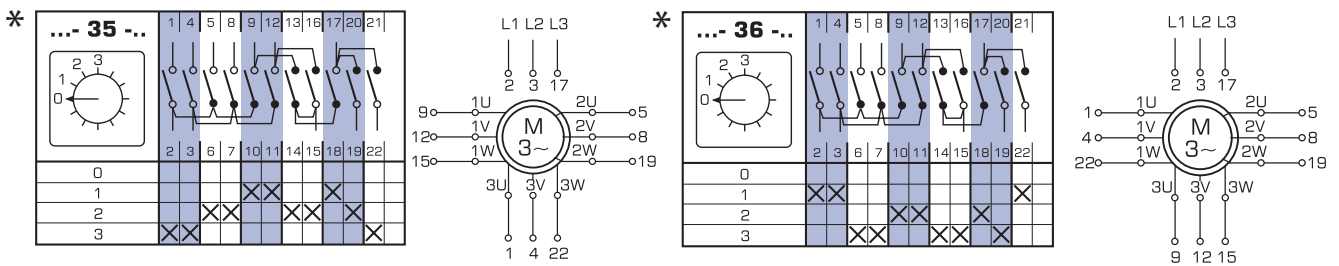

* Only in versions U, OU

SWITCH DISCONNECTORS FOR MOTOR CONTROLLING

Reversing switches

Table 151.

Switching program	Diagram number
2-pole	24
2-pole, return to "0" position	25
3-pole	11
3-pole, return to "0" position	26
to control a contactor	27
starting switches for 1-phase motors	15

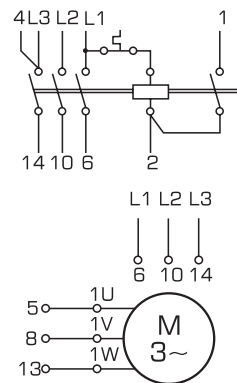
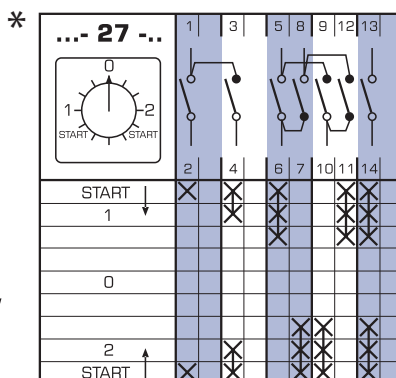
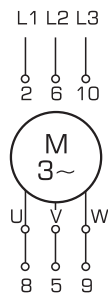
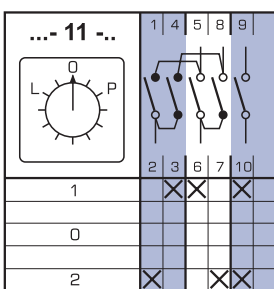
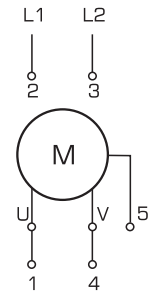
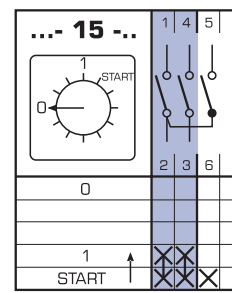
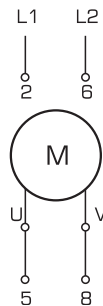
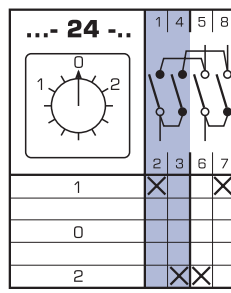
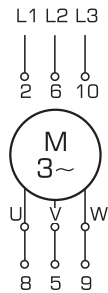
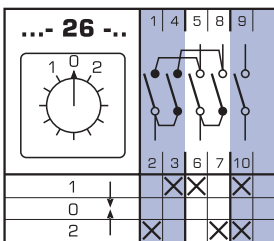
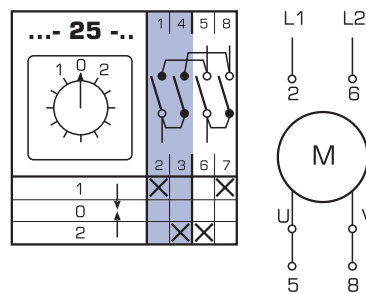

* Only in versions U, OU
* See dimensions on pages 185-188

OVERALL DIMENSIONS

Standard version front plate

Group	B ∅	E
A0	48	7,5
A1	65	9,5
A2	90	9,5
A3	132	10

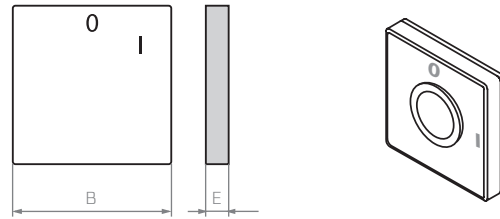

Group	D	P	R	B	F
	∅				
A0	27,5	19	23,5	39,5	16
A1	35	25	32	53	20
A2	48	32	43,5	70,5	26
A3	75	46,5	63,5	104	39

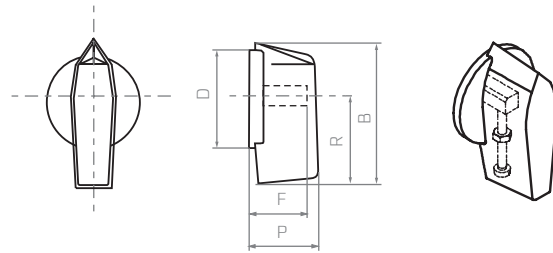

Group	D	P	R	B	F
	∅				
A1	35	51	61,5	81,5	15
A2	48	64	79,5	105,5	19
A3	75	88	115	155,5	28

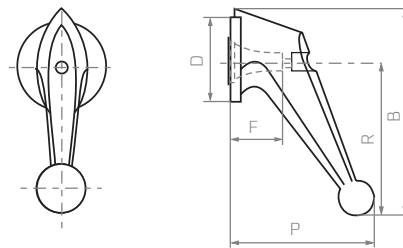

Switches installed under the panel

Group	D1	D2	A
	∅	∅	∅
A0	5	14	36
A1	5	14	48
A2	6	16	72
A3	6	18	104

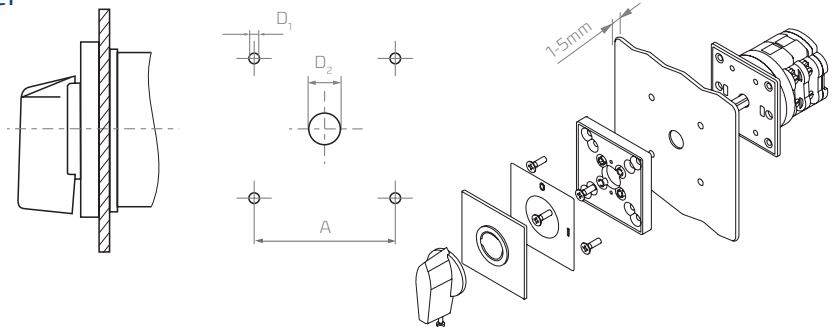

Switches installed on the panel

Group	D1	D2	A
	∅	∅	∅
A0	5	42,5	36
A1	5	59	48
A2	6	82	72

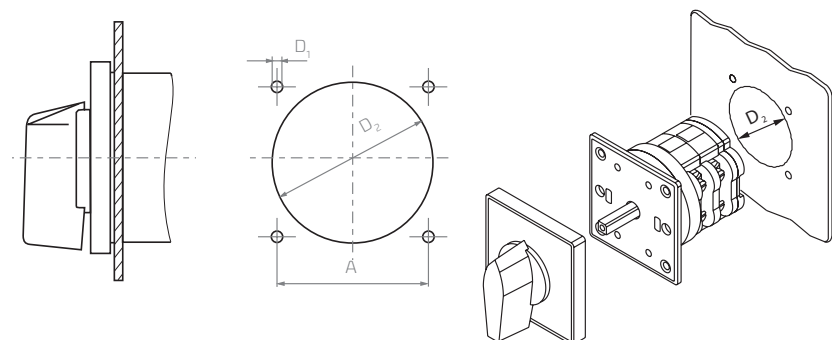

OVERALL DIMENSIONS

U switches to be built-in

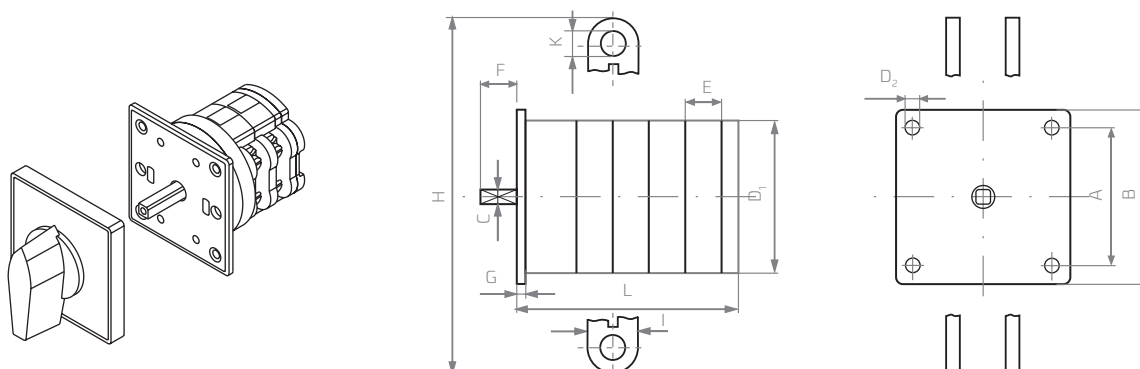

Group	Switch type	D ₁	D ₂	A	B	C	E	F	G	H	I	K
		∅	∅	∅	∅	∅						
A0	4G 10	38	4,3	36	48	6	9,6	22	4	–	–	–
A1	4G 16	57	4,3	48	65	6	13,5	26	3	–	–	–
	4G 25	57	4,3	48	65	6	13,5	26	3	–	–	–
A2	4G 40	80	5,3	72	90	8	18	31	5	–	–	–
	4G 63,80	80	5,3	72	90	8	18	31	5	–	–	–
A3	4G 100	120	5,3	104	132	10	29	37,5	6	–	–	–
	4G 200	120	5,3	104	132	10	29	37,5	6	145	20	10,5
	4G 400	120	5,3	104	132	10	29	37,5	6	170	45	13
	4G 630	120	5,3	104	132	10	29	37,5	6	190	74	17,5
	4G 800	120	5,3	104	132	10	29	37,5	6	260	50	17,5
	4G 1200	120	5,3	104	132	10	29	37,5	6	260	80	17,5

Group	Switch type	L (depending on the number of switching elements)											
		1	2	3	4	5	6	7	8	9	10	11	12
A0	4G 10	33	42,5	52	61,5	71	81	90,5	100	109,5	119	129	138,5
A1	4G 16	46,5	60	73,5	87,5	101	114,5	128,5	143	156	169,5	183	196,5
	4G 25	46,5	60	73,5	87,5	101	114,5	128,5	143	156	169,5	183	196,5
A2	4G 40	56,5	74,5	92,5	110,5	128,5	146,5	164,5	182,5	200,5	218,5	236,5	254,5
	4G 63,80	56,5	74,5	92,5	110,5	128,5	146,5	164,5	182,5	200,5	218,5	236,5	254,5
A3	4G 100	77	107	136	166	196	226	284	314	343	373	402	432
	4G 200	77	107	136	166	196	226	284	314	343	373	402	432
	4G 400	–	107	–	166	–	226	–	314	–	373	–	432
	4G 630	–	–	136	–	–	226	–	–	343	–	–	432
	4G 800	–	107	–	166	–	226	–	314	–	373	–	432
	4G 1200	–	–	136	–	–	226	–	–	343	–	–	432

protection degree IP40 (from the front plate side), IP55 in a special version – S1

OVERALL DIMENSIONS

OU switches to be built in a housing

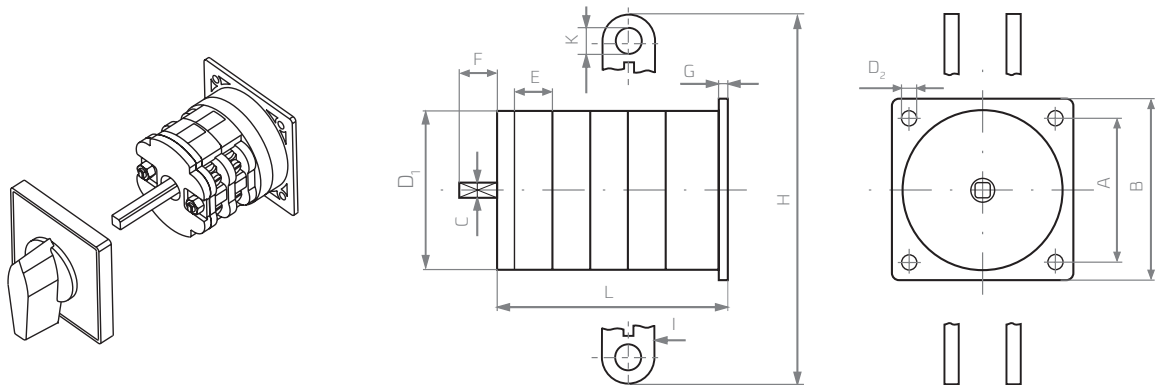

Group	Switch type	D ₁	D ₂	A	B	C	E	F	G	H	I	K
		∅	∅	∅	∅	∅						
A0	4G 10	38	4,3	36	48	6	9,6	32	4	–	–	–
A1	4G 16	57	4,3	48	65	6	13,5	35	3	–	–	–
	4G 25	57	4,3	48	65	6	13,5	35	3	–	–	–
A2	4G 40	80	5,3	72	90	8	18	40	5	–	–	–
	4G 63,80	80	5,3	72	90	8	18	40	5	–	–	–
A3	4G 100	120	5,3	104	132	10	29	50	6	–	–	–
	4G 200	120	5,3	104	132	10	29	50	6	145	20	10,5
	4G 400	120	5,3	104	132	10	29	50	6	170	45	13
	4G 630	120	5,3	104	132	10	29	50	6	190	74	17,5
	4G 800	120	5,3	104	132	10	29	50	6	260	50	17,5
	4G 1200	120	5,3	104	132	10	29	50	6	260	80	17,5

Group	Switch type	L (depending on the number of switching elements)											
		1	2	3	4	5	6	7	8	9	10	11	12
A0	4G 10	33	46,5	56	65,5	75	85	94,5	104	113,5	123	133	142,5
A1	4G 16	46,5	60	73,5	87,5	101	114,5	128,5	143	156	169,5	183	196,5
	4G 25	46,5	60	73,5	87,5	101	114,5	128,5	143	156	169,5	183	196,5
A2	4G 40	56,5	74,5	92,5	110,5	128,5	146,5	164,5	182,5	200,5	218,5	236,5	254,5
	4G 63,80	56,5	74,5	92,5	110,5	128,5	146,5	164,5	182,5	200,5	218,5	236,5	254,5
A3	4G 100	77	107	136	166	196	226	284	314	343	373	402	432
	4G 200	77	107	136	166	196	226	284	314	343	373	402	432
	4G 400	–	107	–	166	–	226	–	314	–	373	–	432
	4G 630	–	–	136	–	–	226	–	–	343	–	–	432
	4G 800	–	107	–	166	–	226	–	314	–	373	–	432
	4G 1200	–	–	136	–	–	226	–	–	343	–	–	432

protection degree IP40 (from the front plate side), IP55 in a special version – S1

INSTALLATION DIMENSIONS

PK switches in a plastic housing - protection degree IP55

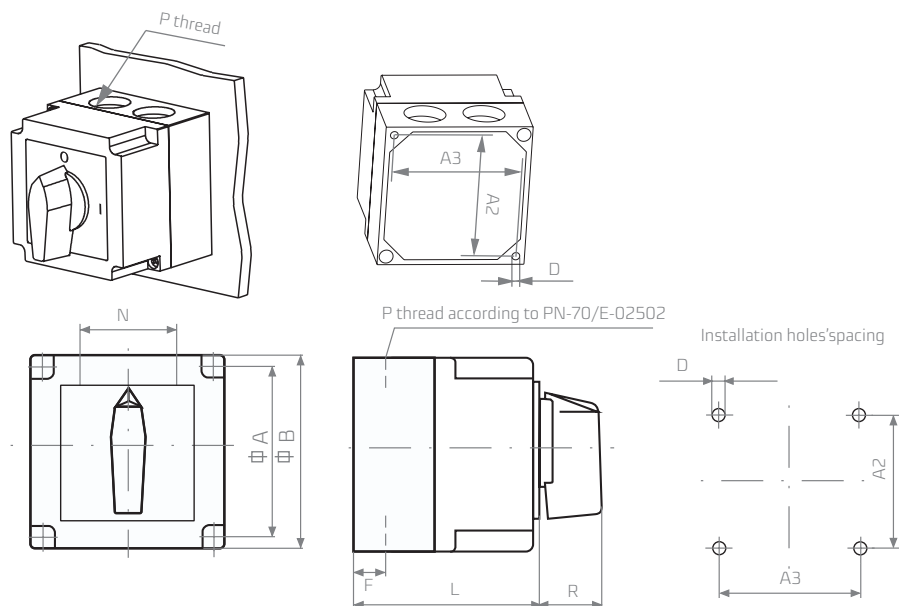

Group	Switch type	D	A	A2	A3	B	F	N	R	Thread		L (depending on the number of the switching elements)			
										P	M	1	2	3	4
A0	4G 10	4,3	55	38	54	64	13	25	19	11	-	55,5	55,5	75	75
A1	4G 16	4,3	75	75	75	85	19	34	25	16	20	77	77	104	104
	4G 25	4,3	75	75	75	85	19	34	25	16*	20	77	77	104	104
A2	4G 40	5,3	109	91	107	120	29	45	32	21*	-	95	95	132	132
	4G 63, 4G 80	5,3	109	91	107	120	29	45	32	21	-	95	95	132	132

* to order

PK cam switches in thermoplastic enclosures with IP65 degree of protection

Installation holes' spacing

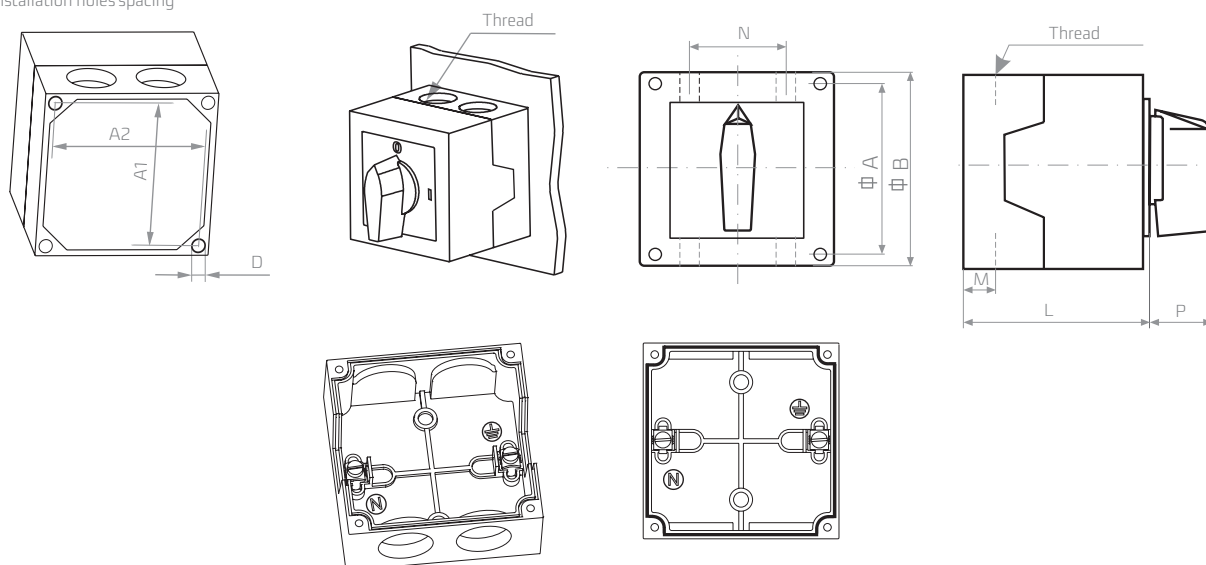

Group	Switch type	D	A	B	A1	A2	M	N	P	Thread	L (depending on the number of the switching elements)	
											1 or 2	3 or 4
A0	4G 10	4,5	64	75	50	64	14	28	19	M20	60	81,5

SPECIAL VERSIONS

S1 switch with a sealed shaft /protection class IP55/

Group A0, A1, A2 version U, OU

The difference between standard and special versions is the use of a sealing ring on the driving shaft, which guarantees achieving an IP55 housing tightness.

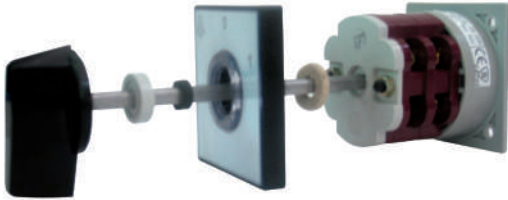

S5 switch with a cylindrical lock

Group A1, A2 version U

Blocking when ordered.

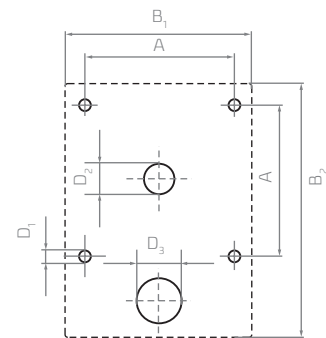
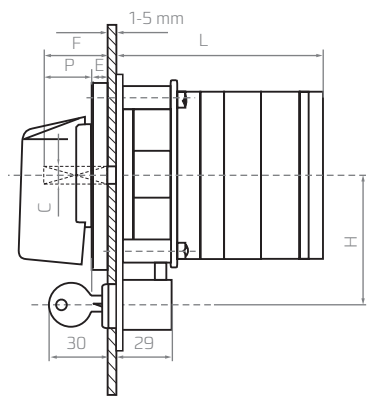

Group	D ₁	D ₂	D ₃	A	B ₁	B ₂	C	E	F	H	P	
								Φ				
A1	5	14	21,5	48	65	98	6	9,5	26	48	25	
A2	6	16	21,5	72	90	122	8	9,5	31	60	32	

Group	L (depending on the number of the switching elements)											
	1	2	3	4	5	6	7	8	9	10	11	12
A1	72,5	86	99,5	113,5	127	140,5	154,5	169	182	195,5	209	222,5
A2	82,5	100,5	118,5	136,5	154,5	172,5	190,5	208,5	226,5	244,5	262,5	280,5

S6 Switch with padlock blocking

Group A0, A1, A2 version U, OU, PK
Blocking only in 0 position

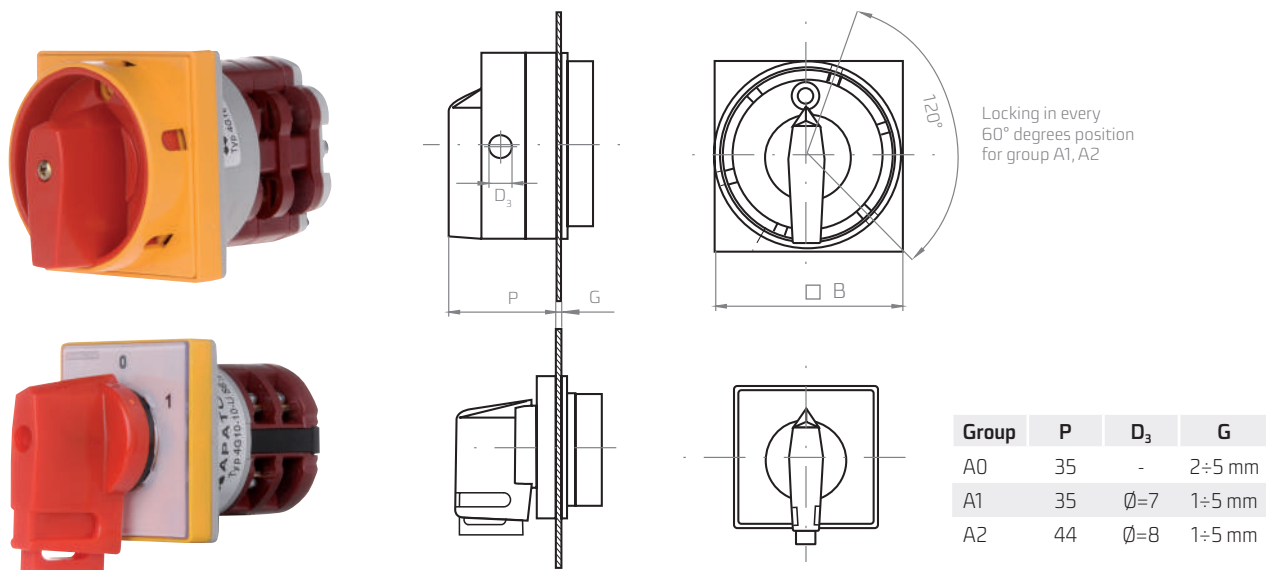

Locking in every 60° degrees position for group A1, A2

S7 Switch with a door coupling

Group A1, A2 version OU

The switch for installation on the back wall of the housing /cubicle/. The knob with a front plate is placed on the cover or on the door. The shaft may be lengthened and sealed.

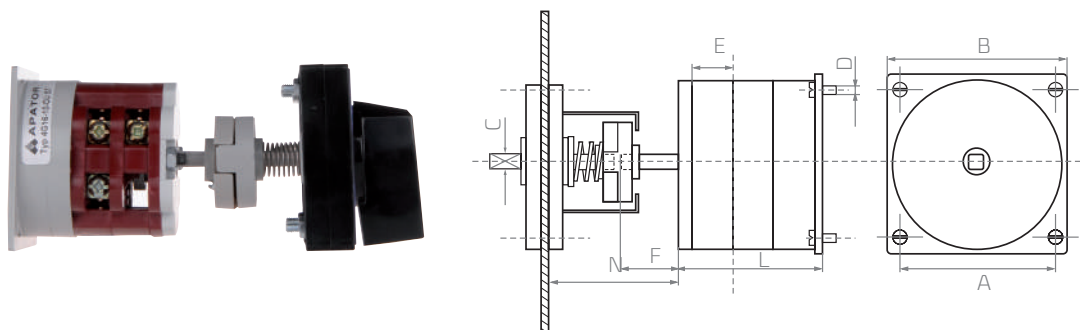

S8 Switch with a door coupling and a door blocking

Group A1, A2 version OU

The features are like for S7, but the door can be opened in a 0 position, for example.

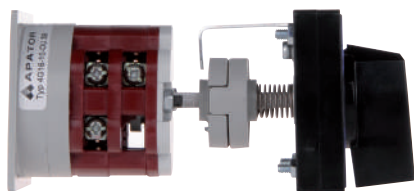

Group	D	A	B	C	E	F	N	L (depending on the number of the switching elements)											
								1	2	3	4	5	6	7	8	9	10	11	12
A1	4	48	65	6	13,5	16,5	54	46,5	60	73,5	87,5	101	114,5	128,5	143	156	169,5	183	196,5
A2	5	72	90	8	18	17	60	56,5	74,5	95,5	110,5	128,5	146,5	164,5	182,5	200,5	218,5	236,5	254,5

S9 Switch for installation in $\varnothing 30,5$ (in control boards with standard holes)

Group A0 version U

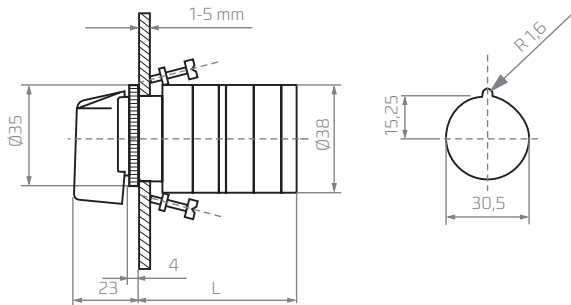

S10 Switch for installation in a $\varnothing 30,5$ hole

Group A0 version U

(Like for S9), the key operates as a knob. Closing in positions 3, 6, 9, 12 /like on a clock/. The key can be removed in the same positions.

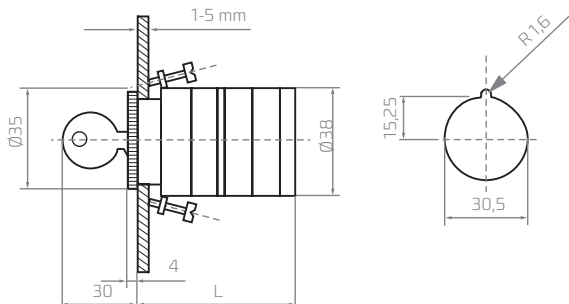

S11 Switch for installation in a $\varnothing 22,5$ hole (control boards)

Group A0 version U

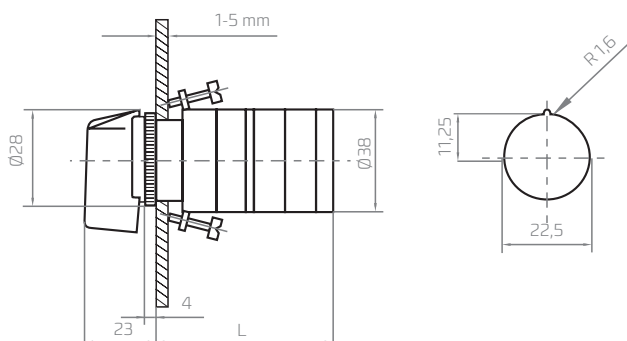

S12 switch for installation in a $\varnothing 22,5$ hole (like for s11)

Group A0 version U

The key operates as a knob. Closing and removing the key in positions like for S10.

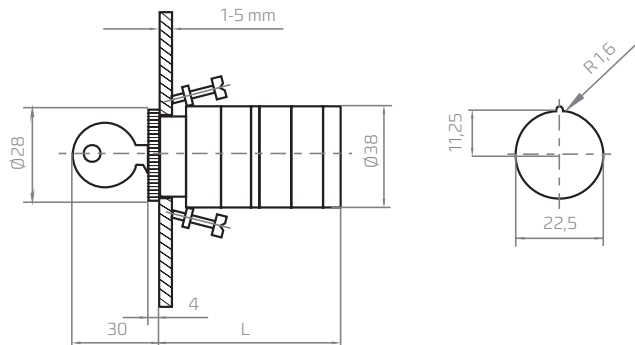

Version: S9, S10, S11, S12	L (dependent on the number of switching elements)											
	1	2	3	4	5	6	7	8	9	10	11	12
	47	56,5	66	75,5	85	95	104,5	114	123,5	133	143	152,5

S15 Switch with a signal lamp

Group A0, A1, A2 version U, OU, PK*)

*protection degree IP52

(Standard colour – red; 220 V).

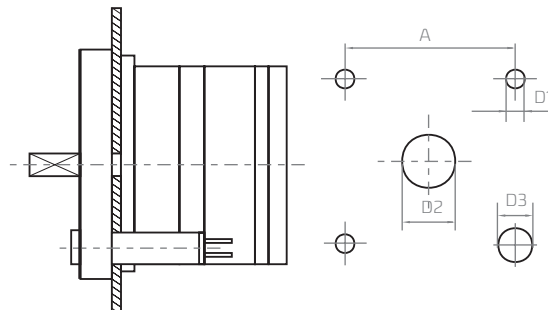

Group	A	D ₁	D ₂	D ₃
	Φ	ø	ø	ø
A0	35	5	14	9
A1	48	5	14	9
A2	72	6	16	9

S18 Switch for installation on din rail (according to 35 DIN EN 50022)

Group A0, A1, A2 version U

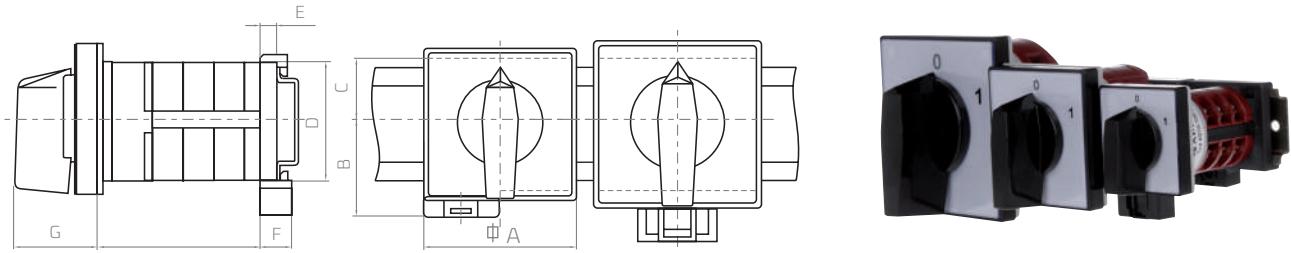

Group	A	B	C	D	E	F	G
	ϕ						
A0	48	30	21	35	5	10,5	26,5
A1	65	48,5	21	35	9	15	34,5
A2	90	48,5	21	35	9	15	41,5

S19 Switch with a protective housing (up to two packs)

Group A1, A2 version U, OU

Protection to prevent from touching the terminals.

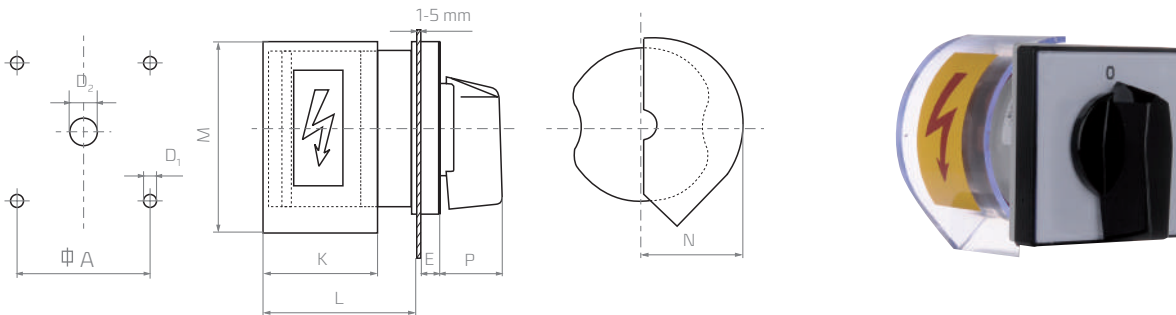

Group	D ₁	D ₂	A	E	P	K	M	N	L
	ϕ	ϕ	ϕ						
A1	5	14	48	9,5	25	51	78	36	69
A2	6	16	72	9,5	32	58	99	53	78

S21 Main switch disconnecter according to IEC 204 and VDE 0113

Group A1, A2, A3 version U

Black knob, front plate and indicating plate, white markings. Protecting housing like in S19. Blocking lock. Blocking according to order.

S22 Emergency and main switch disconnecter (for two packs)

Group A1, A2, A3 version U

Red knob, yellow background of an indicating plate, black markings. Protecting housing like in S19. Blocking lock. Blocking according to order.

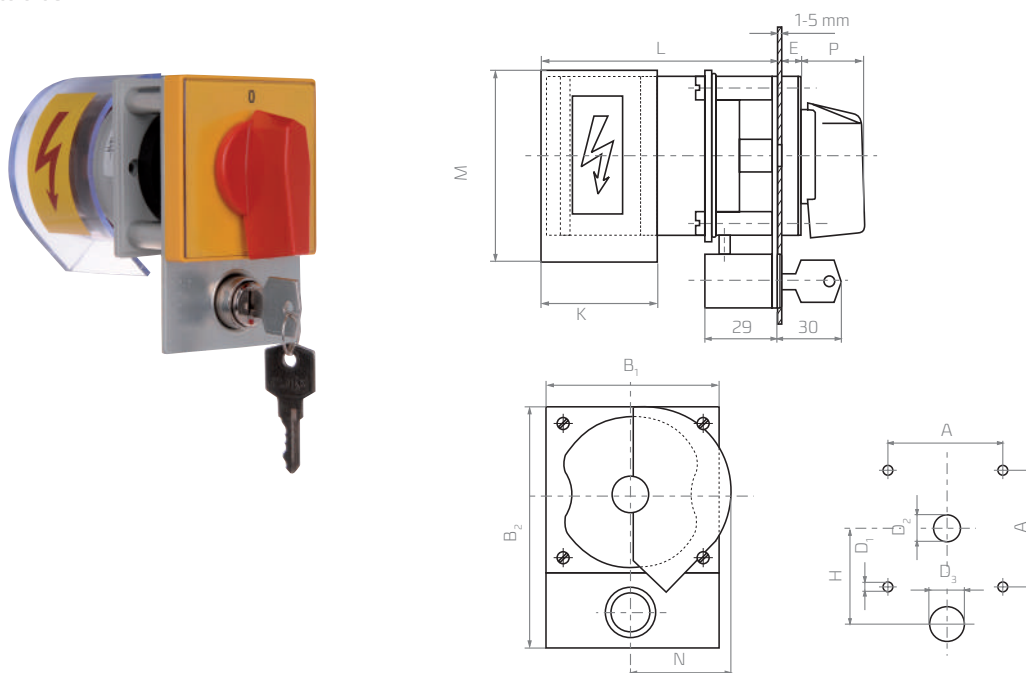

Group	D ₁	D ₂	D ₃	A	B ₁	B ₂	P	K	M	N	L	E	H
	∅	∅	∅										
A1	5	14	21,5	48	65	98	25	51	78	36	95	9,5	48
A2	6	16	21,5	72	90	122	32	58	99	53	104	9,5	60
A3	6	18	21,5	104	132	168	46,5	88	132	78	137	10	85

S24 Emergency switch disconnecter according to IEC 204 and VDE 0113

Group A0, A1, A2 version U, OU, PK

Red knob, yellow background of an indicating plate, black markings. The difference between standard and special versions is in different colours of a knob and a plate (red knob, yellow plate, black signs).



S25 Main and emergency switch disconnector (for two packs)

Group A1, A2 version U, OU

The blocking position should be specified (red knob, yellow front plate) in the order. Blocking only in 0 position.

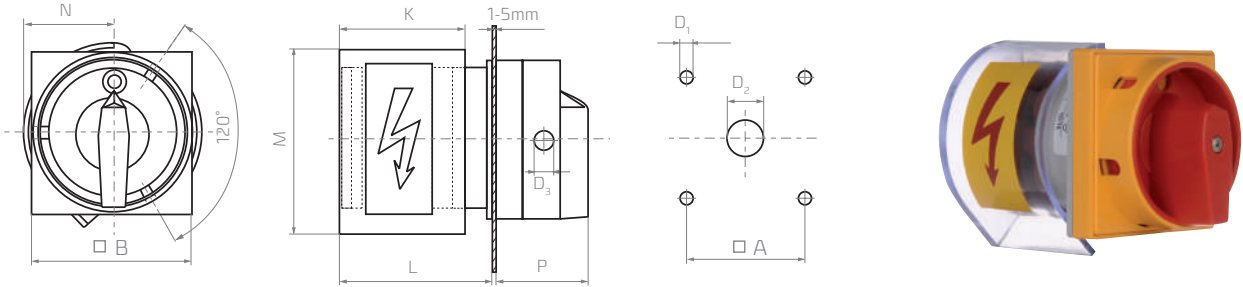

Group	D ₁	D ₂	D ₃	A	B	P	K	M	N	L
	∅	∅	∅	∅	∅					
A1	5	14	7	48	65	35	51	78	36	69
A2	6	16	8	72	90	44	58	99	53	78

S29 Switch for installation in a ∅22,5 hole /in control boards/

Group A0 version U

The key operates as a knob. Closing in positions 3, 6, 9, 12 /like on a clock/. The key can be removed in the same positions. It is possible to remove the key in the same positions.

S30 Switch for installation in a ∅30,5 hole with a front plate /in control boards/

Group A0 version U

The key operates as a knob. Closing in positions 3, 6, 9, 12 /like on a clock/. The key can be removed in the same positions. It is also possible to remove the key in any position.

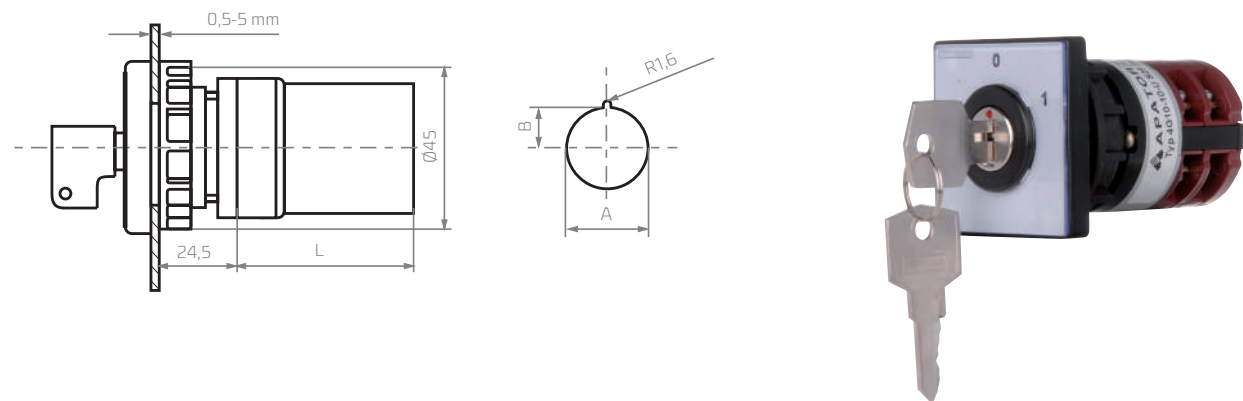

Group	S29	S30
A	22,5	30,5
B	11,25	15,25

The number of the switching elements	1	2	3	4	5	6	7	8	8	10	11	12
L	29	38,5	48	57,5	67	77	86,5	96	105,5	115	125	134

THE CHOICE OF THE MOTOR SWITCHES

Contact life depends on loading conditions. In AC-1 utilization category, where making currents and breaking currents are the same and equal the rated current, the contact life of the switches up to 4G 63 size reaches one million of switching operations.

In more difficult operating conditions the contact life becomes lower. The diagram presented below can be used to make an approximate choice of motor switches, depending on voltage, motor power, number of switching operations per hour and usage class.

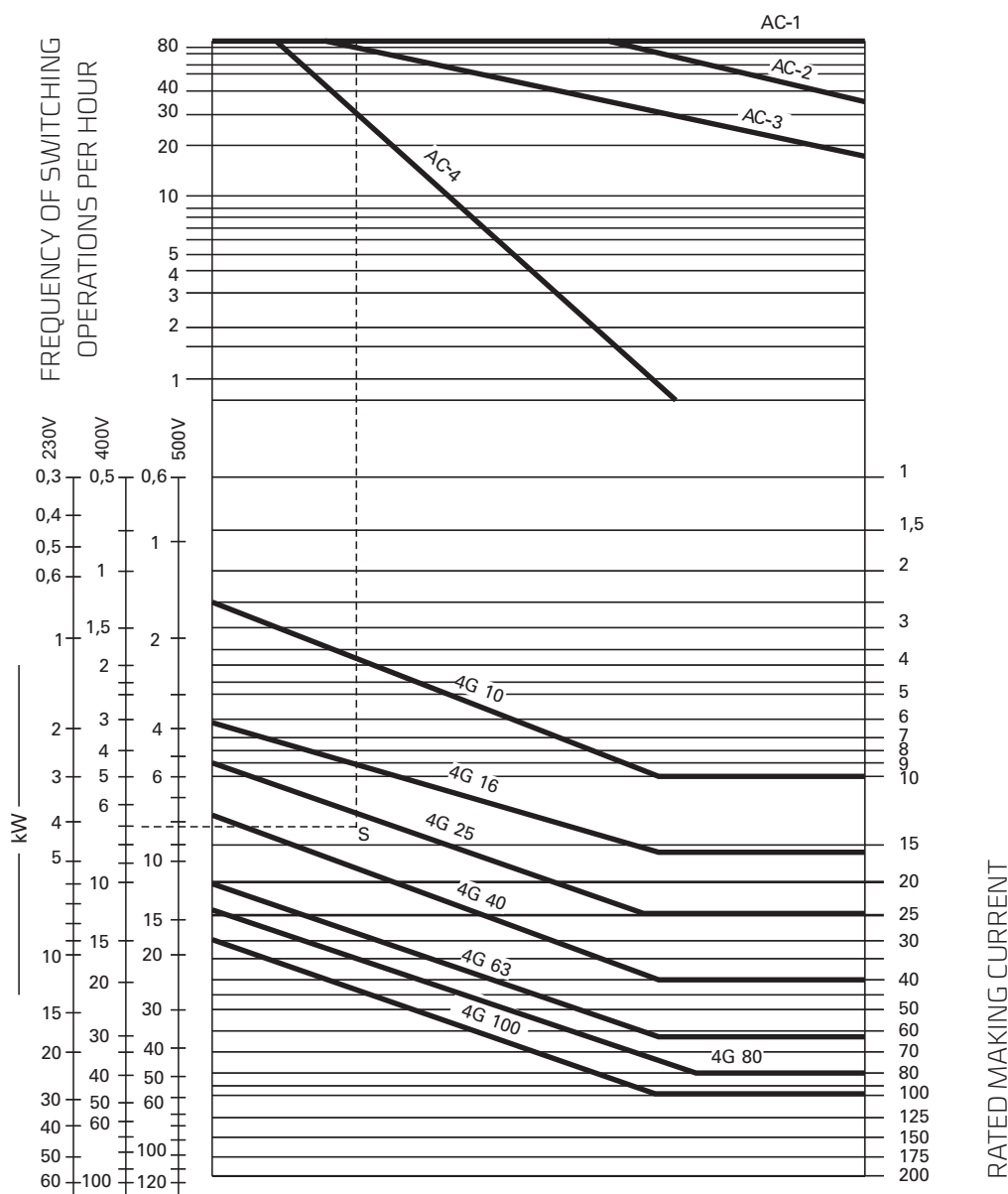
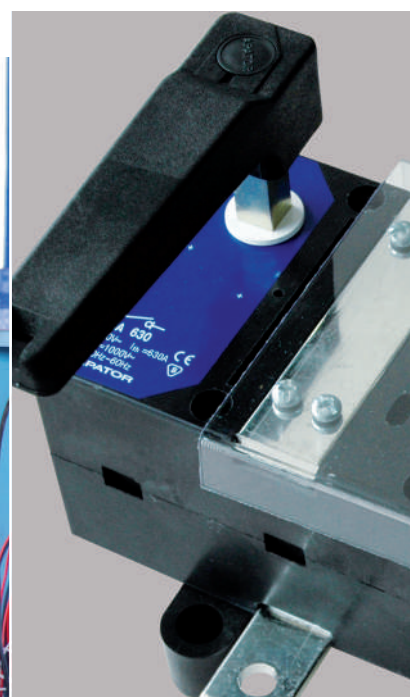

Diagram application example:

The task is to select a cam switch for direct switching and counter-current braking of a squirrel-cage motor characterized by the rated power 7 kW, 380 V and 30 switching operations per hour:

1. Utilization category: AC-4.
2. Find the number of switching operations in the diagram: 30 per hour /in the top part of the diagram/.
3. Draw a horizontal line from the point you have found from the point of intersection with relevant utilization category (AC-4).
4. In the bottom part of the diagram, find the motor power (7 kW, 380 V) on the scale of proper voltage and draw a horizontal line to the right.
5. Draw a perpendicular line down from the point of intersection of the top horizontal line with the utilization category line (AC-4).
6. The point of intersection with the bottom horizontal line "S" lies in the area related to the switch type you are looking for (4G 40).



RA
switch disconnectors

RAB
switch disconnectors fuses

- RA switch disconnectors and RAB switch disconnectors fuses are designed for distribution of electricity, making and breaking currents and protection of electrical equipment against shortcircuits and overloads with industrial fuse links.

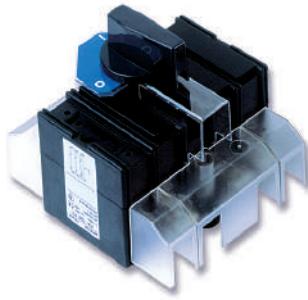

RA100P3/R
+ cable terminal shrouds



RAB1P3/OHY
+ fuse link shroud

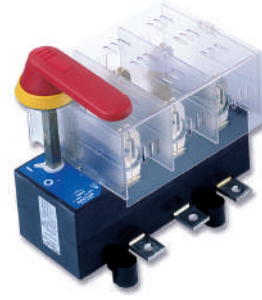

RAB2P3/OHY
+ fuse link shroud

R type series is divided into two groups:

- RA switch disconnectors
 - 3-pole with optional neutral (N) 4th pole
 - RA100 - 4th pole switchable
- RAB switch disconnectors fuses
 - 3-pole with optional neutral (N) 4th pole
 - RAB000 - 4th pole switchable

GENERAL INFORMATION

- safety of service and easy installation,
- self-extinguishing thermoplastics (V0 flammability class),
- silver plated parts of current circuits,
- self-tightening and self-cleaning contacts,
- high electrical and mechanical endurance,
- high short-circuit making and breaking capacity,
- double, safe clearance between open contacts,
- complete isolation of fuse links in „off“ position,
- manually operated drive (spring powered),
- wide range of accessories.

APPLICATIONS

Switch disconnectors series **R** are designed for distribution of electricity and protection against short circuits and overloads in three phase alternative current circuits. They can be used as:

- main switch disconnecter in distribution boards,
- switch disconnecter,
- switch disconnecter for motor control and protection.

OPERATING CONDITIONS

- to be installed in the room free of any dust, aggressive or explosive gases,
- for moderate, marine and tropical climate,
- ambient temperature from -25°C to +55°C,
- altitude up to 2000 meters above sea level,
- outdoor – in cabinets with protection degree > IP34.

CONSTRUCTION AND OPERATION

RA switch disconnectors and **RAB** switch disconnectors fuses consists of following parts:

- bottom part of the body with fitted current circuits (stationary contacts, cable terminals)
- top part of the body with fitted contacts (**RA**) or spring loaded contacts for fuse link blades (**RAB**)
- traverse with moving contacts
- manually operated drive (spring powered)

Current circuit of each phase has four clearances between contacts in switched off position(double clearance for each pair of contacts, two pairs of contacts for each phase phase) ensuring required isolating distance and safe replacement of fuse links in **RAB** switch disconnectors fuses. Manually triggered, springpowered drive delivers rapid switching. **RA** switch disconnectors and **RAB** switch disconnectors fuses can be equipped with two types of handles:

- R type - installed on disconnector's shaft
- OHB, OHY type - for installation on distribution board's door

Handle position indicates disconnector's state - switched on or switched off. OHB and OHY handles are designed for locking by up to three padlocks in OFF („0”) position. Handles are available in colours black and yellow-red. Wide range of accesories is available for **RA** switch disconnectors and **RAB** switch disconnectors fuses like additional shafts, shaft joints, auxiliary switches, cable terminal shrouds, fuse link shrouds, etc.

INSTALLATION

RA switch disconnectors and **RAB** switch disconnectors fuses are designed for operation in horizontal or vertical position with permissible deviation of 30° in any direction. **RA** switch disconnectors and **RAB** switch disconnectors fuses should be mounted to support structure with screws with spring washers.

Table 152. Screw terminals tightening torque

Screw	M6	M8	M10	M12
Tightening torque	7 Nm	14 Nm	24 Nm	38 Nm

Table 153. RA technical data

Article	Unit	RA 100	RA 160	RA 250	RA 400	RA 630	RA 1250
Parameter		Value					
Rated thermal current	I_{th} A	100	160	250	400	630	1250
Rated insulation voltage	U_i V	1000					
Rated impulse withstand voltage	U_{imp} kV	8					
Rated frequency	Hz	50 ÷ 60					
Rated switching current for AC 22A $U_e = 690$ V	I_e A	100	125	125	250	400	-
Rated switching current for AC 22B $U_e = 690$ V	I_e A	-	-	-	400	630	-
Rated switching current for AC 22A $U_e = 500$ V	I_e A	-	-	-	-	-	1250
Rated switching current for AC 22B $U_e = 415$ V	I_e A	-	-	250	-	-	-
Rated switching current for AC 23A $U_e = 500$ V	I_e A		160	160	-	-	-
Rated switching current for AC 23A $U_e = 690$ V	I_e A	40	-	-	-	-	-
Rated short-circuit making capacity	I_{cm} kA _{max}	7	9	20	25	35	100
Rated short-time withstand current 1 s	I_{cw} kA	2,5	8	8	15	15	50
Mechanical durability	number of cycles	10000	8000	8000	5000	5000	3000
Electrical durability at utilization category AC 22 A		1500	1000	1000	1000	1000	500
Duty	-	Continuous duty					
Protection degree IP	-	IP 00					
Weight	kg	0,95	1,7	1,85	3,3	4,3	12,5
Busbar cross-section	mm ²	15 x 2	20 x 4	25 x 4	2 x 25 x 4	2 x 30 x 5	60 x 10
Cable conductor cross-section	mm ²	35	95	120	240	2 x 185	-

Table 154. RA switch disconnectors with standard cable terminals

Type	I _n	Number of poles	Accessories*	Article	Article No.
RA 100	100 A	3	-	RA 100 P3	63-823064-011
		3 + N	-	RA 100 P3 N	63-823064-091
		4	-	RA 100 P4	63-823064-051
		3	R1	RA 100 P3/R	63-823064-131
		3 + N	R1	RA 100 P3 N/R	63-823064-211
		4	R1	RA 100 P4/R	63-823064-171
RA 160	160 A	3	-	RA 160 P3	63-822982-011
		3 + N	-	RA 160 P3 N	63-822982-031
		3	R1	RA 160 P3/R	63-822982-051
RA 250	250 A	3 + N	R1	RA 160 P3 N/R	63-822982-071
		3	-	RA 250 P3	63-822982-021
		3 + N	-	RA 250 P3 N	63-822982-041
RA 400	400 A	3	R1	RA 250 P3/R	63-822982-061
		3 + N	R1	RA 250 P3 N/R	on request
		3	-	RA 400 P3	63-811593-011
RA 630	630 A	3 + N	-	RA 400 P3 N	63-811593-031
		3	R1	RA 400 P3/R	63-811593-051
		3 + N	R1	RA 400 P3 N/R	on request
RA 1250	1250 A	3	-	RA 630 P3	63-811593-021
		3 + N	-	RA 630 P3 N	63-811593-041
		3	R1	RA 630 P3/R	63-811593-061
		3 + N	R1	RA 630 P3 N/R	on request
		3	-	RA 1250 P3	63-811601-011
		3 + N	-	RA 1250 P3 N	63-811601-021
		3	R1	RA 1250 P3/R	63-811601-031
		3 + N	R1	RA 1250 P3 N/R	63-811601-041

* R1 - handle mounted on shaft

CAUTION! N - 4th pole unswitchable, switchable 4th pole available only for RA100 type switch disconnectors

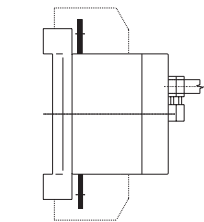

RA 100 P3



RA 100 P3/R

Table 155. RA switch disconnectors with „A“ type cable terminals

Type	I _n	Number of poles	Accessories*	Article	Article No.
RA 100	100 A	3	-	RA 100 P3 A	63-823064-021
		3 + N	-	RA 100 P3 NA	63-823064-101
		4	-	RA 100 P4 A	63-823064-061
		3	R1	RA 100 P3 A/R	63-823064-141
		3 + N	R1	RA 100 P3 NA/R	63-823064-221
		4	R1	RA 100 P4 A/R	63-823064-181
RA 160	160 A	3	-	RA 160 P3 A	63-823165-011
		3 + N	-	RA 160 P3 NA	63-823165-021
		3	R1	RA 160 P3 A/R	63-823165-131
RA 250	250 A	3 + N	R1	RA 160 P3 NA/R	63-823165-141
		3	-	RA 250 P3 A	63-823165-031
		3 + N	-	RA 250 P3 NA	63-823165-041
RA 400	400 A	3	R1	RA 250 P3 A/R	63-823165-151
		3 + N	R1	RA 250 P3 NA/R	63-823165-161
		3	-	RA 400 P3 A	63-811618-011
RA 630	630 A	3 + N	-	RA 400 P3 NA	63-811618-031
		3	R1	RA 400 P3 A/R	63-811618-131
		3 + N	R1	RA 400 P3 NA/R	63-811618-151
		3	-	RA 630 P3 A	63-811618-021
		3 + N	-	RA 630 P3 NA	63-811618-041
		3	R1	RA 630 P3 A/R	63-811618-141
		3 + N	R1	RA 630 P3 NA/R	63-811618-161

* R1 - handle mounted on shaft

A

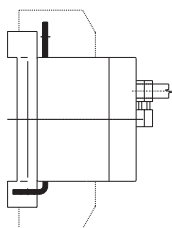

RA 250 P3 A

Table 156. RA switch disconnectors with „B” type cable terminals

Type	I _n	Number of poles	Accessories*	Article	Article No.
RA 100	100 A	3	-	RA 100 P3 B	63-823064-031
		3 + N	-	RA 100 P3 NB	63-823064-111
		4	-	RA 100 P4 B	63-826064-071
		3	R1	RA 100 P3 B/R	63-823064-151
		3 + N	R1	RA 100 P3 NB/R	63-823064-231
		4	R1	RA 100 P4 B/R	63-823064-191
RA 160	160 A	3	-	RA 160 P3 B	63-823165-051
		3 + N	-	RA 160 P3 NB	63-823165-061
		3	R1	RA 160 P3 B/R	63-823165-171
		3 + N	R1	RA 160 P3 NB/R	63-823165-181
RA 250	250 A	3	-	RA 250 P3 B	63-823165-071
		3 + N	-	RA 250 P3 NB	63-823165-081
		3	R1	RA 250 P3 B/R	63-823165-191
RA 400	400 A	3 + N	R1	RA 250 P3 NB/R	63-823165-201
		3	-	RA 400 P3 B	63-811618-051
		3 + N	-	RA 400 P3 NB	63-811618-071
RA 630	630 A	3	R1	RA 400 P3 B/R	63-811618-171
		3 + N	R1	RA 400 P3 NB/R	63-811618-191
		3	-	RA 630 P3 B	63-811618-061
		3 + N	-	RA 630 P3 NB	63-811618-081
RA 250	250 A	3	R1	RA 630 P3 B/R	63-811618-181
		3 + N	R1	RA 630 P3 NB/R	63-811618-201

* R1 - handle mounted on shaft

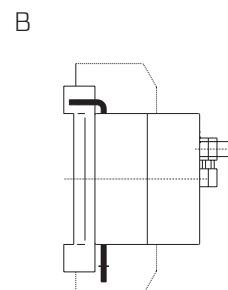

RA 250 P3 B

Table 157. RA switch disconnectors with „C” type cable terminals

Type	I _n	Number of poles	Accessories*	Article	Article No.
RA 100	100 A	3	-	RA 100 P3 C	63-823064-041
		3 + N	-	RA 100 P3 NC	63-823064-121
		4	-	RA 100 P4 C	63-823064-081
		3	R1	RA 100 P3 C/R	63-823064-161
		3 + N	R1	RA 100 P3 NC/R	63-823064-241
		4	R1	RA 100 P4 C/R	63-823064-201
RA 160	160 A	3	-	RA 160 P3 C	63-823165-091
		3 + N	-	RA 160 P3 NC	63-823165-101
		3	R1	RA 160 P3 C/R	63-823165-211
RA 250	250 A	3 + N	R1	RA 160 P3 NC/R	63-823165-221
		3	-	RA 250 P3 C	63-823165-111
		3 + N	-	RA 250 P3 NC	63-823165-121
RA 400	400 A	3	R1	RA 250 P3 C/R	63-823165-231
		3 + N	R1	RA 250 P3 NC/R	63-823165-241
		3	-	RA 400 P3 C	63-811618-091
RA 630	630 A	3 + N	-	RA 400 P3 NC	63-811618-111
		3	R1	RA 400 P3 C/R	63-811618-211
		3 + N	R1	RA 400 P3 NC/R	63-811618-231
		3	-	RA 630 P3 C	63-811618-101
RA 250	250 A	3 + N	-	RA 630 P3 NC	63-811618-121
		3	R1	RA 630 P3 C/R	63-811618-221
		3 + N	R1	RA 630 P3 NC/R	63-811618-241

* R1 - handle mounted on shaft

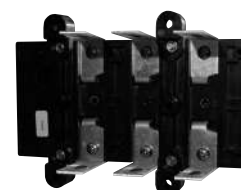
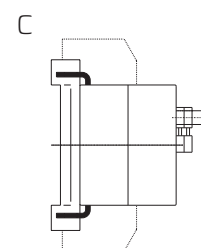

RA 250 P3 C

Dimensions of RA100

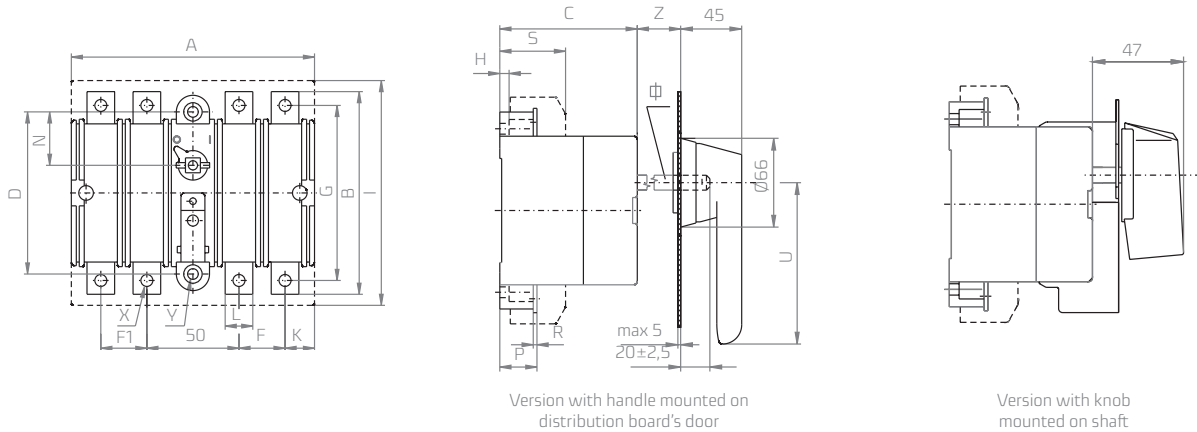

Dimension [mm]	A	B	C	D	E	F	F1	G	H	I	K	L	L1	M	N	O	P	R	S	U	X	Y	Z	∅	W
RA 100	132	110	74	88	-	25	25	95	5	150	16	15	-	-	29	-	20	2	50	65	6,5	5,8	20	8	-

Dimensions of RA 160, RA 250, RA 400, RA 630

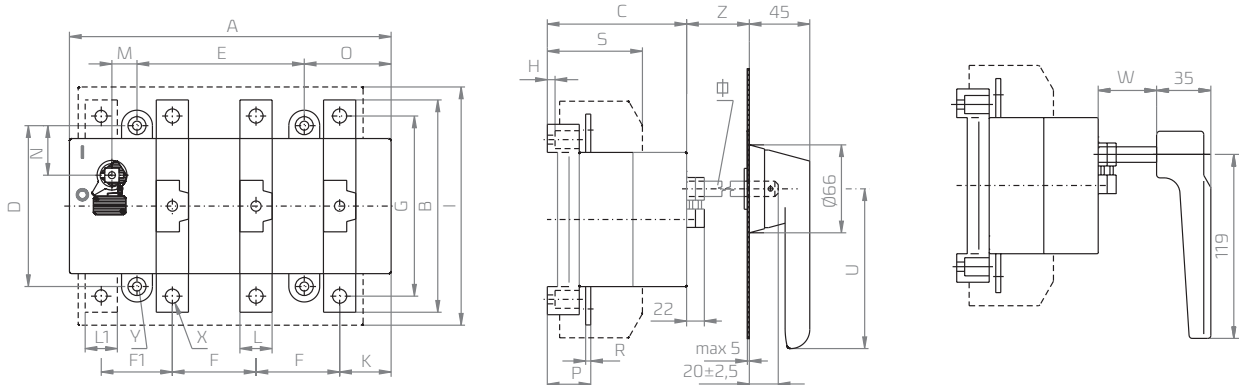

Dimension [mm]	A	B	C	D	E	F	F1	G	H	I	K	L	L1	M	N	O	P	R	S	U	X	Y	Z	∅	W	
RA 160																		3	61	95	8,8	5,8	43	10	32	
RA 250																		3,5								
RA 400																		34	4	86	125	11	7	47	12	32
RA 630																		30	5							

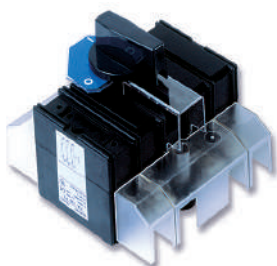

RA 100 P3/R
with additional terminal shroud

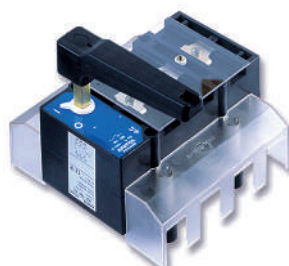

RA 160 P3/R
with additional terminal shroud



RA 160 P3/OHB
with additional terminal shroud

CABLE TERMINALS OF TYPE A, B, C

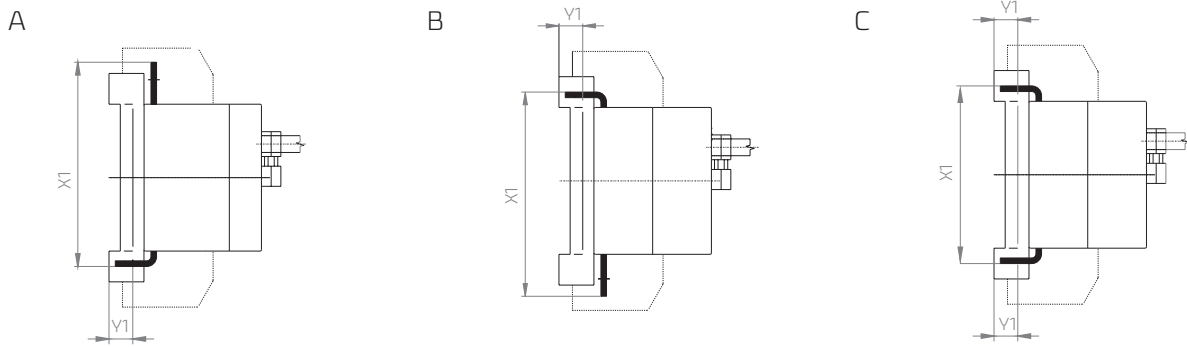

Dimensions of cable terminals [mm]	RA 160			RA 250			RA 400			RA 630		
	A	B	C	A	B	C	A	B	C	A	B	C
X1	111	111	90	111	111	90	140,5	140,5	116	146	146	127
Y1	8,5	8,5	8,5	8,5	8,5	8,5	13	13	13	13	13	13

Dimensions of RA1250

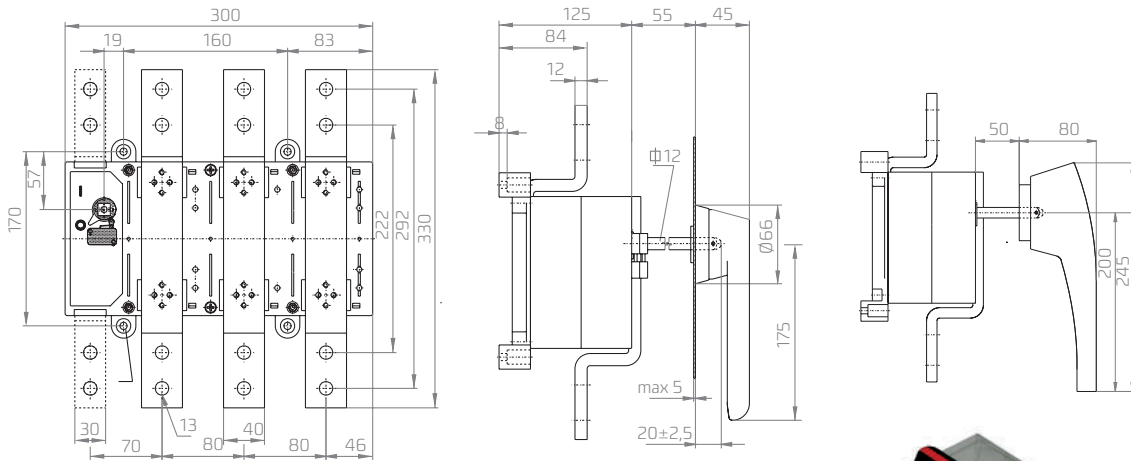

RA 1250 P3/OHB

For installation behind assembly panel
RA 160/250

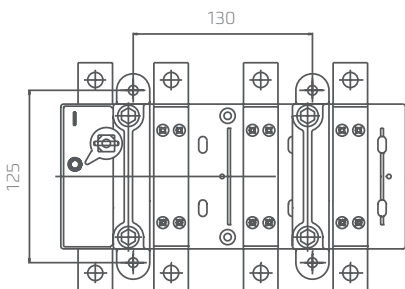

RA 400/630

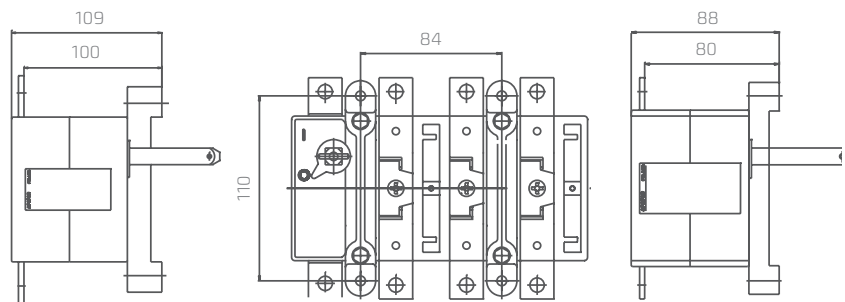

CAUTION!
lengthening of shaft is possible by adding second shaft,
connected by shaft link (see Accessories)

CHANGE-OVER SWITCHES I-O-II



2 x RA 160 P3

I - O - II	Poles	I _n	Article No. of RA switch	Article No. of coupling mechanism	
				handle mounted on shaft	handle OHB mounted on distribution board's door
160	3	160 A	2 x RA 160 P3 (63-822982-011)	+63-839949-011	+63-839949-021
250	3	250 A	2 x RA 250 P3 (63-822982-021)	+63-839949-011	+63-839949-021
400	3	400 A	2 x RA 400 P3 (63-811593-011)	+63-839972-011	+63-839972-021
630	3	630 A	2 x RA 630 P3 (63-811593-021)	+63-839972-011	+63-839972-021
1250	3	1250 A	2 x RA 1250 P3 (63-811601-011)	+63-930893-011	+63-930893-021

Dimensions of change-over switch I-O-II

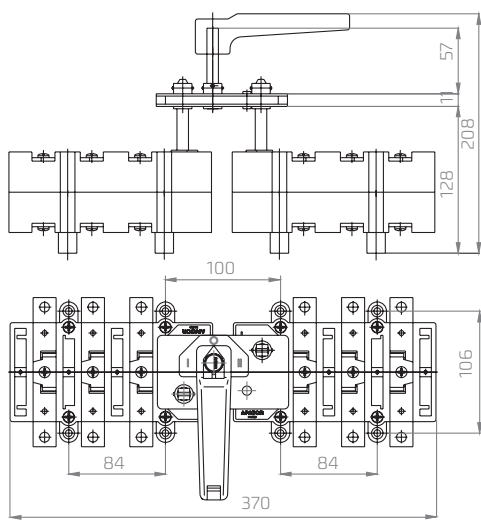

160 A - 250 A

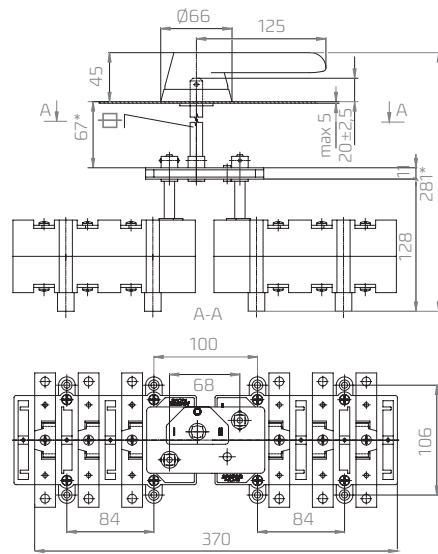

160 A - 250 A

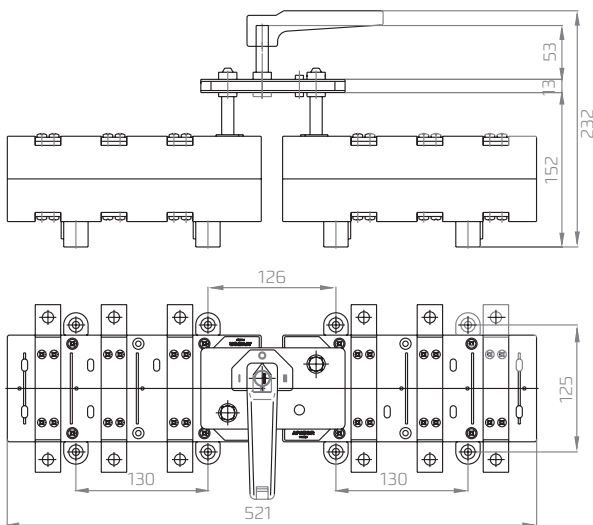

400 A - 630 A

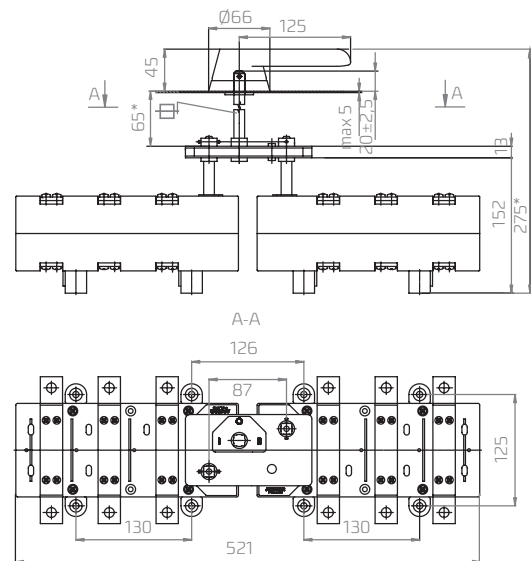

400 A - 630 A

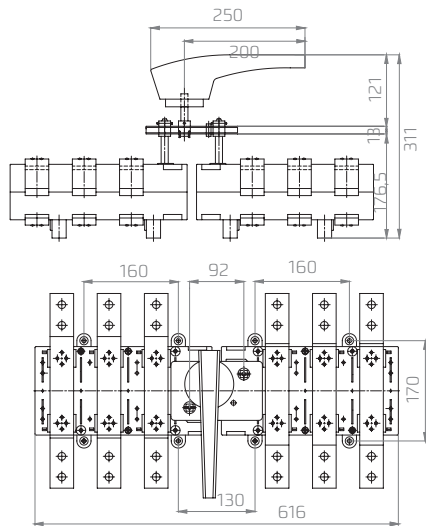

1250 A
handle mounted on shaft

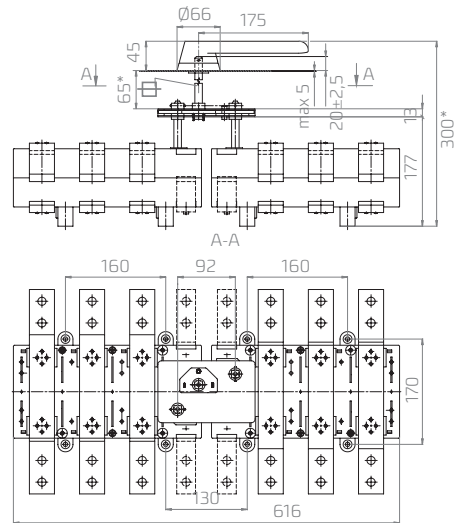

1250 A
handle mounted on distribution board's door

L-minimal distance between shaft and door's hinge

hole in enclosure's cover for mounting of OHB handles

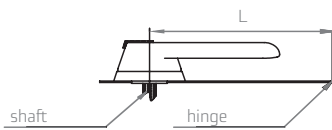

mounting position of shaft and shaft's pin

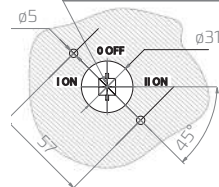

Switch disconnecter	Length [mm]	Handle
RA 100		
RAB 000	80	OH...65 J8
RA 160/250		
RAB 00	120	OH...95 J10
RA 400/630		
RAB 1/2	150	OH...125 J12
RAB 3	200	OH...145 J12
RA 1250	200	OH...175 J12

RAB switch disconnectors fuses

Table 158. RAB technical data

Article	Unit	RAB 000	RAB 00	RAB 1	RAB 2	RAB 3
Parameter		Value				
Rated thermal current	I_{th} A	100	160	250	400	630
Rated insulation voltage	U_i V	1000				
Rated impulse withstand voltage	U_{imp} kV	8				
Rated frequency	Hz	50 ÷ 60				
Rated switching current for AC 22A $U_e = 690$ V	I_e A	100	125	250	400	-
Rated switching current for AC 22B $U_e = 690$ V	I_e A	-	-	-	-	630
Rated switching current for AC 23A $U_e = 690$ V	I_e A	40	-	-	-	-
Rated switching current for AC 23A $U_e = 500$ V	I_e A	-	160	-	-	-
Rated switching current for AC 23A $U_e = 415$ V	I_e A	-	-	-	-	630
Rated power dissipation	W	7,5	12	32	45	60
Fused short-circuit current $I_n = I_{th}$	kA	100				
Mechanical durability	number of cycles	10000	8000	8000	5000	5000
Electrical durability at utilization category AC 22 A	number of cycles	1500	1000	1000	1000	1000
Duty	-	Praca ciągła				
Protection degree IP	-	IP 00				
Weight	kg	1,05	2,0	3,65	4,2	7,5
Busbar cross-section	mm ²	15 x 2	25 x 4	2 x 25 x 4	2 x 30 x 5	2 x 40 x 60
Cable conductor cross-section	mm ²	35	120	240	2 x 185	-

Table 159. RAB switch disconnectors fuses with standard cable terminals

Type	I_n	Number of poles	Accessories*	Article	Article No.
RAB 000	100 A	3	-	RAB 000 P3	on request
		3 + N	-	RAB 000 P3 N	on request
		4	-	RAB 000 P4	63-823063-051
		3	R1	RAB 000 P3/R	on request
		3 + N	R1	RAB 000 P3 N/R	on request
RAB 00	160 A	4	R1	RAB 000 P4/R	on request
		3	-	RAB 00 P3	on request
		3 + N	-	RAB 00 P3 N	on request
RAB 1	250 A	3	R1	RAB 00 P3/R	on request
		3 + N	R1	RAB 00 P3 N/R	on request
		3	-	RAB 1 P3	on request
		3 + N	-	RAB 1 P3 N	on request
RAB 2	400 A	3	R1	RAB 1 P3/R	on request
		3 + N	R1	RAB 1 P3 N/R	on request
		3	-	RAB 2 P3	on request
		3 + N	-	RAB 2 P3 N	on request
RAB 3	630 A	3	R1	RAB 2 P3/R	63-811529-061
		3 + N	R1	RAB 2 P3 N/R	on request
		3	-	RAB 3 P3	on request
RAB 00 P3/OHB	630 A	3 + N	-	RAB 3 P3 N	on request
		3	R1	RAB 3 P3/R	63-811564-031
		3 + N	R1	RAB 3 P3 N/R	on request

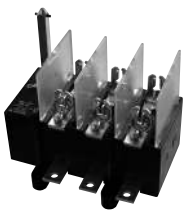
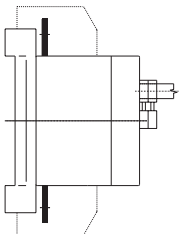

RAB 00 P3



RAB 00 P3/OHB

*R1 - handle mounted on shaft
CAUTION!

N - 4th pole unswitchable, switchable 4th pole available only for RA100 type switch disconnectors!

Table 160. RAB switch disconnectors fuses with „A” type cable terminals

Type	I _n	Number of poles	Accessories*	Article	Article No.
RAB 000	100 A	3	-	RAB 000 P3 A	63-823063-021
		3 + N	-	RAB 000 P3 NA	63-823063-101
		4	-	RAB 000 P4 A	63-823063-061
		3	R1	RAB 000 P3 A/R	on request
		3 + N	R1	RAB 000 P3 NA/R	on request
		4	R1	RAB 000 P4 A/R	on request
RAB 00	160 A	3	-	RAB 00 P3 A	on request
		3 + N	-	RAB 00 P3 NA	on request
		3	R1	RAB 00 P3 A/R	on request
		3 + N	R1	RAB 00 P3 NA/R	on request
RAB 1	250 A	3	-	RAB 1 P3 A	on request
		3 + N	-	RAB 1 P3 NA	on request
		3	R1	RAB 1 P3 A/R	on request
		3 + N	R1	RAB 1 P3 NA/R	on request
RAB 2	400 A	3	-	RAB 2 P3 A	on request
		3 + N	-	RAB 2 P3 NA	on request
		3	R1	RAB 2 P3 A/R	on request
		3 + N	R1	RAB 2 P3 NA/R	on request
RAB 3	630 A	3	-	RAB 3 P3 A	on request
		3 + N	-	RAB 3 P3 NA	on request
		3	R1	RAB 3 P3 A/R	on request
		3 + N	R1	RAB 3 P3 NA/R	on request

*R1 - handle mounted on shaft

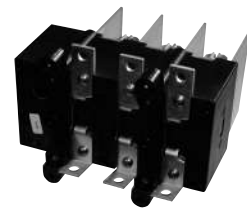
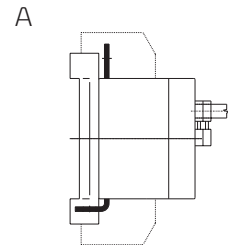

RAB 00 P3 A

Table 161. RAB switch disconnectors fuses with „B” type cable terminals

Type	I _n	Number of poles	Accessories*	Article	Article No.
RAB 000	100 A	3	-	RAB 000 P3 B	63-823063-031
		3 + N	-	RAB 000 P3 NB	63-823063-111
		3 + N	-	RAB 000 P4 B	63-823063-071
		3	R1	RAB 000 P3 B/R	on request
		3 + N	R1	RAB 000 P3 NB/R	on request
		4	R1	RAB 000 P4 B/R	on request
RAB 00	160 A	3	-	RAB 00 P3 B	on request
		3 + N	-	RAB 00 P3 NB	on request
		3	R1	RAB 00 P3 B/R	on request
		3 + N	R1	RAB 00 P3 NB/R	on request
RAB 1	250 A	3	-	RAB 1 P3 B	on request
		3 + N	-	RAB 1 P3 NB	on request
		3	R1	RAB 1 P3 B/R	on request
		3 + N	R1	RAB 1 P3 NB/R	on request
RAB 2	400 A	3	-	RAB 2 P3 B	on request
		3 + N	-	RAB 2 P3 NB	on request
		3	R1	RAB 2 P3 B/R	on request
		3 + N	R1	RAB 2 P3 NB/R	on request
RAB 3	630 A	3	-	RAB 3 P3 B	on request
		3 + N	-	RAB 3 P3 NB	on request
		3	R1	RAB 3 P3 B/R	on request
		3 + N	R1	RAB 3 P3 NB/R	on request

*R1 - handle mounted on shaft

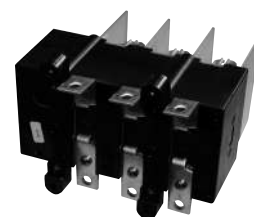
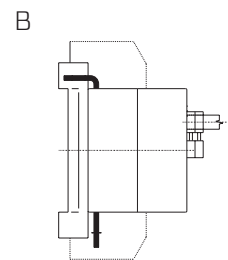

RAB 00 P3 B

Table 162. RAB switch disconnectors fuses with „C” type cable terminals

C

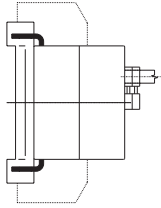

RAB 00 P3 C

Type	I _n	Number of poles	Accessories*	Article	Article No.
RAB 000	100 A	3	-	RAB 000 P3 C	63-823063-041
		3 + N	-	RAB 000 P3 NC	63-823063-121
		4	-	RAB 000 P4 C	63-823063-081
		3	R1	RAB 000 P3 C/R	on request
		3 + N	R1	RAB 000 P3 NC/R	on request
RAB 00	160 A	4	R1	RAB 000 P4 C/R	on request
		3	-	RAB 00 P3 C	on request
		3 + N	-	RAB 00 P3 NC	on request
RAB 00	160 A	3	R1	RAB 00 P3 C/R	on request
		3 + N	R1	RAB 00 P3 NC/R	on request
		3	-	RAB 1 P3 C	on request
RAB 1	250 A	3 + N	-	RAB 1 P3 NC	on request
		3	R1	RAB 1 P3 C/R	on request
		3 + N	R1	RAB 1 P3 NC/R	on request
RAB 2	400 A	3	-	RAB 2 P3 C	on request
		3 + N	-	RAB 2 P3 NC	on request
		3	R1	RAB 2 P3 C/R	on request
RAB 2	400 A	3 + N	R1	RAB 2 P3 NC/R	on request
		3	-	RAB 3 P3 C	on request
		3 + N	-	RAB 3 P3 NC	on request
RAB 3	630 A	3	R1	RAB 3 P3 C/R	on request
		3 + N	R1	RAB 3 P3 NC/R	on request
		3 + N	R1	RAB 3 P3 C/R	on request

*R1 - handle mounted on shaft

Dimensions of RAB 000 (100 A)

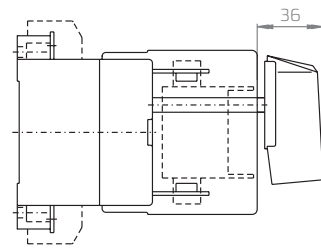
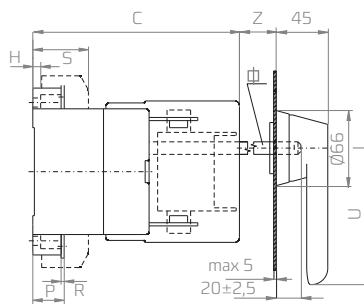
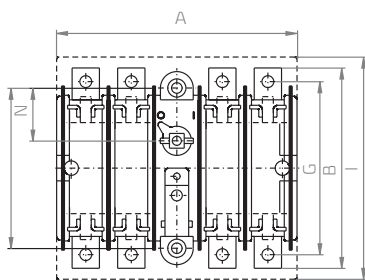

Version with handle mounted on distribution board's door

Version with handle mounted on shaft

Dimension [mm]	A	B	C	D	E	G	H	I	L1	M	N	O	P	R	S	U	Z	Ø	W
RAB 000	132	110	132	88	-	95	5	150	-	-	29	-	20	2	50	65	20	8	-

Dimensions of RAB 00, RAB 1, RAB 2, RAB 3

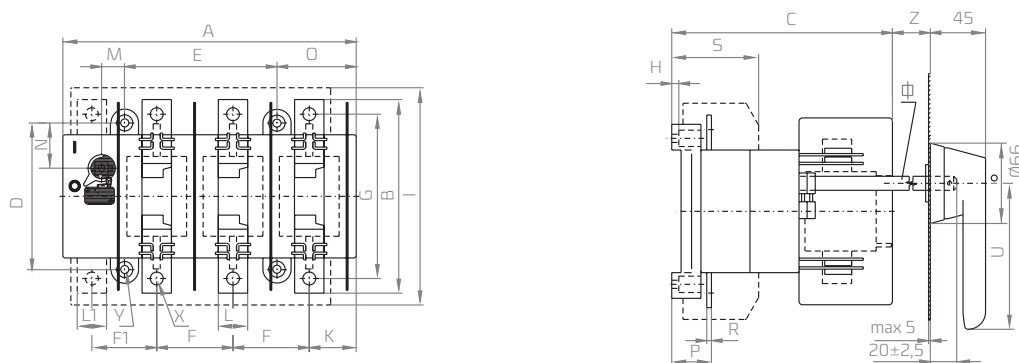

Dimension [mm]	A	B	C	D	E	F	F1	G	H	I	K	L	L1	M	N	O	P	R	S	U	X	Y	Z	φ	W
RAB 00	176	132	150	110	84	42	42	115	5	170	30	20	20	16	36	51	26	3,5	61	95	8,5	5,8	15	10	20
RAB 1	250	174	189	125	130	65	55	149	8	225	40	25	25	20	38,5	67,5	34	4	86	125	11	7	15	12	25
RAB 2																	30	5							
RAB 3	300	240	215	170	160	80	70	200	8	270	45,5	40	30	19	56,5	83	40	6	97	145	13	7	20	12	-

Cable terminals of type A, B, C

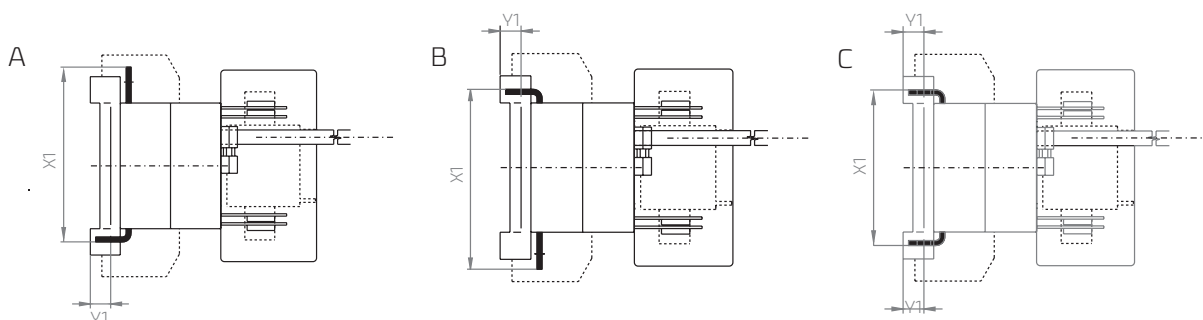

Dimensions of cable terminals [mm]	RAB 00			RAB 1			RAB 2		
	A	B	C	A	B	C	A	B	C
X1	111	111	90	140,5	140,5	116	146	146	127
Y1	8,5	8,5	8,5	8,5	8,5	8,5	13	13	13

CAUTION!
lengthening of shaft is possible by adding second shaft, connected by shaft link (see Accessories)

Dimensions of RA switch disconnectors, RAB switch disconnectors fuses (with cable terminals of type A, B, C) with side support element for mounting

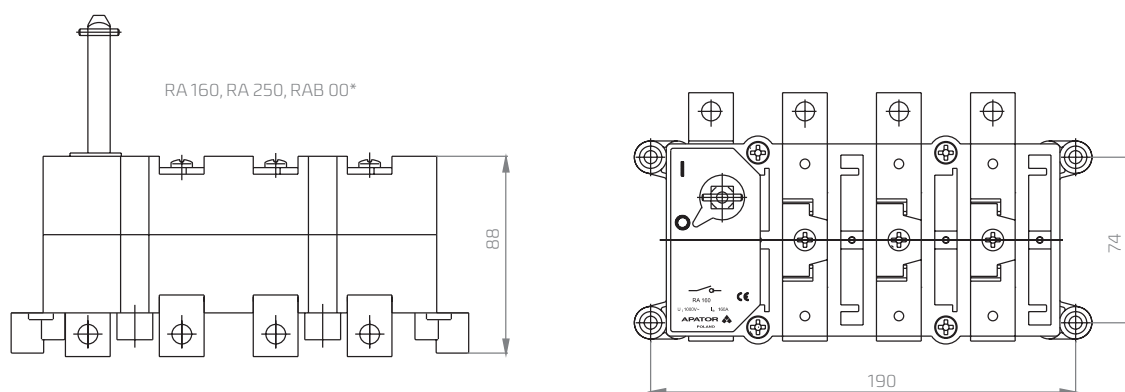

RA 400, RA 630, RAB 1, RAB 2*

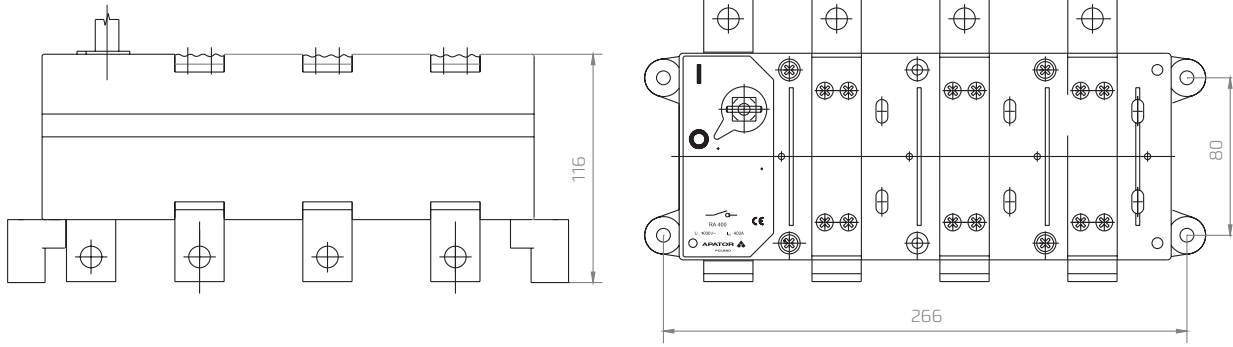

* ordered with switch

L-minimal distance between shaft and door's hinge

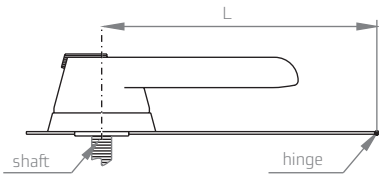

hole in enclosure's cover or door for mounting of OHB handles

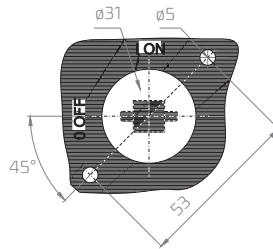

Switch disconnector	Length [mm]	Handle
RA 100	80	OH...65 J8
RAB 000		
RA 160/250	120	OH...95 J10
RAB 00		
RA 400/630	150	OH...125 J12
RAB 1/2		
RAB 3	200	OH...145 J12
RA 1250	200	OH...175 J12

Fuse link shrouds

Article No.	For use with switch of type	Number of shrouds mounted on switch	Number of shrouds in package	Additional informations
53-944921-011				3-poles
53-944921-021	RAB 000	1	1	4-poles
53-944921-031	RAB 00	1	1	
53-944921-041	RAB 1; RAB 2	1	1	
53-944921-051	RAB 3	1	1	



Handles

Handle for mounting on doors with IP65, ON/OFF position marking, designed for locking by up to three padlocks in OFF („0”) position, door interlock with release mechanism for opening in position I/ON, RA../R, RAB../R - handle mounted on shaft

Article	Colour	Handle length [mm]	For shaft with side length of [mm]	For use with switch of type	Set (pcs.)
H1	black	0	6	RA 100	1
H2	yellow-red			RAB 000	
OHB 95J10	black	95	10	RA 160/250	1
OHY 95J10	yellow-red			RAB 00	
OHB 125J12	black	125	12	RA 400/630	1
OHY 125J12	yellow-red			RAB 1/2	
OHB 145J12	black	145	12	RAB 3	1
OHY 145J12	yellow-red				
OHB 175J12	black	175	12	RA 1250	1
OHY 175J12	yellow-red				



H2



OHB

Shafts

Shafts of various length for switch disconnectors mounted in distribution boards.

Article No.	Shaft size [mm]	Length [mm]	For use with switch of type	Set (pcs.)
52-037741-001	∅6	150	RA 100 RAB 000	1
52-037741-002		400		
52-037741-003		600		
51-943952-051	∅8	100	RA 100 RAB 000	1
51-943952-061		200		
51-943952-071		400		
51-943952-081		600		
51-944280-051	∅10	100	RA 160/250 RAB 00	1
51-944280-061		200		
51-944280-071		400		
51-944280-081	600			
0659900400	∅12	100	RA 400/630/1250 RAB 1/2/3	1
0659900401		200		
51-943953-081		400		
0659900402	600			



Extension shafts for use with coupling mechanism for change-over switch disconnectors:

- handle mounted on shaft - shaft with side length of 10 mm with shaft link
- handle mounted on distribution board's door - shaft with side length of 12 mm with shaft link

Shaft links

For fixing extension shaft to switch disconnector's shaft

Article No.	Shaft size [mm]	For use with switch of type	Set (pcs.)
53-944917-041	∅6	RA 100, RAB 000	1
53-944917-051	∅8/6	RA 100, RAB 000	1
53-944917-011	∅8	RA 100 .../R, RAB 000 .../R	1
53-944917-021	∅10	RA 160/250, RAB 00	1
53-944917-031	∅12	RA 400/630/1250, RAB 1/2/3	1



Extension shafts with shaft links

Article No.	Shaft size [mm]	Length [mm]	For use with switch of type	Set (pcs.)
63-946239-051	∅6	150	RA 100 RAB 000	1
63-946239-061		400		
63-946239-071		600		
63-946239-011	∅8	100	RA 100 RAB 000	1
63-946239-021		200		
63-946239-031		400		
63-946239-041		600		
63-946240-011	∅10	100	RA 160/250 RAB 00	1
63-946240-021		200		
63-946240-031		400		
63-946240-041	600			
63-946241-011	∅12	100	RA 400/630/1250 RAB 1/2/3	1
63-946241-021		200		
63-946241-041		400		
63-946241-031		600		



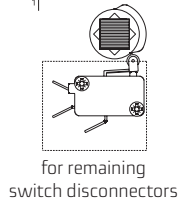
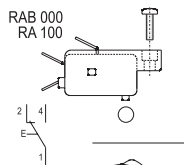

Terminal shrouds

Article No.	For use with switch of type	Number of shrouds mounted on switch	Number of shrouds in package
51-839842-011	RA 100, RAB 000	2	1
51-838546-011	RA 160/250, RAB 00	2	1
51-839843-011	RA 400/630, RAB 1/2/3	6 (8)*	1

*for 3-pole switch disconnectors - 6 pcs., for 3-pole switch disconnectors with N-bar - 8 pcs.

Support element for mounting on support structure

Article No.	For use with switch of type	Number of pcs. in package (set)
On request	RAB 00, RA 160, RA 250	1
On request	RA 400, RA 630, RAB 1, RAB 2	1

Coupling mechanism for change-over switch disconnectors

Three positions: I-O-II. Mounted on shafts of switch disconnectors

Article No.	Handle mounted on shaft	
	For use with switch of type	Number of pcs. in package (set)
63-839949-011	RA 160/250	1
63-839972-011	RA 400/630	1
63-930893-011	RA 1250	1

Handle OHB mounted in distribution board

Article No.	For use with switch of type	Number of pcs. in package (set)
63-839949-021	RA 160/250	1
63-839972-021	RA 400/630	1
63-930893-021	RA 1250	1

Auxiliary contacts

For signalling of position of switch disconnectors contacts (ON/OFF).

Article No.	Auxiliary switch parameters	For use with switch of type	Number of pcs. in package	Additional information
53-944915-011	AC – 11 U _e 220 V~ I _e 1 A DC – 13 U _e 220 V= I _e 0,25 A	RA 100 RAB 000	1	one switch
53-944916-011	AC – 11 U _e 220 V~ I _e 1 A DC – 13 U _e 220 V= I _e 0,25 A	RA 160/250 RAB 00	1	one switch
53-944916-031		RA 400/630 RAB 1/2/3		
53-944916-021	AC – 11 U _e 220 V~ I _e 1 A DC – 13 U _e 220 V= I _e 0,25 A	RA 160/250 RAB 00	1	two switches
53-944916-041		RA 400/630 RAB 1/2/3		

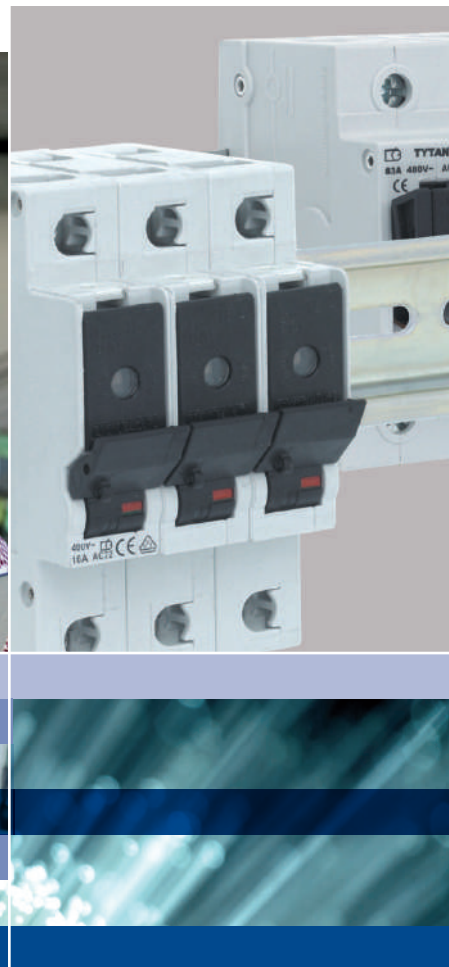

Modular equipment

Mounted on DIN 35 mm rail

DO - TYTAN® II FUSE SWITCH DISCONNECTOR



35 mm DIN rail

- flashing response indicator (in the fuse sleeve)
- full coding for all current values of the fuse link
- possibility of sealing
- possibility of blocking



Table 163. Technical data

Classification	Fuse switch disconnecter
Standard	IEC/EN 60947-3
Adapted to fuse switch disconnectors	D01: 1, 2, 4, 6, 10, 13, 16 A D02: 20, 25, 32, 35, 40, 50, 63 A gL, gG, aM class
flammability class/track resistance	V0, glowing wire testing 960°C / CTI 600
Degree of protection/touch protection	IP 20 / protection against finger and palm touch
Rated operating voltage U_e	
-AC	400 V
-DC	1-pole 110 V, 2-pole 220 V
Rated switching current I_e	63 A
Rated impulse withstand voltage U_{imp}	6 kA
Rated short-circuit current I_{cm}	50 kA _{eff}
Utilization category	AC 22B, DC 21 B
Overtoltage category/pollution degree	IV/3 (DIN VDE 0110)
Terminal type	stainless steel cage terminals 1.5...35 mm ² ; MD 4 Nm

TYTAN II fuse switch disconnecter should be equipped with a fuse sleeve (see Table 167)

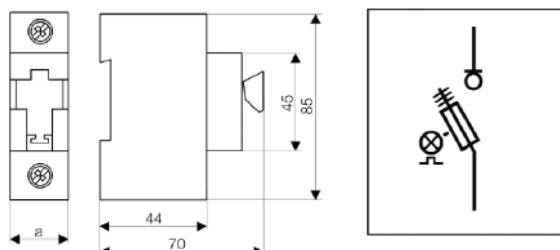

Table 164. Construction width

Article no.	Construction width a [mm]
0000102651T	27
0000102652T	54
0000102653T	81
0000102641T	54
0000102643T	108





Table 165. TYTAN II Fuse switch disconnector

Versions	Index no.	Weight [kg]	Package [pcs.]
1-pole	0000102651T	0,12	12
2-pole	0000102652T	0,23	6
3-pole	0000102653T	0,35	4
1-pole + N	0000102641T	0,25	6
3-pole + N	0000102643T	0,48	3

TYTAN II fuse switch disconnector should be equipped with a fuse sleeve (see Table 167)

Flawless differentiation of rated current due to full coding

The TYTAN® system codes the nominal current with coloured fuse links for each current stage.

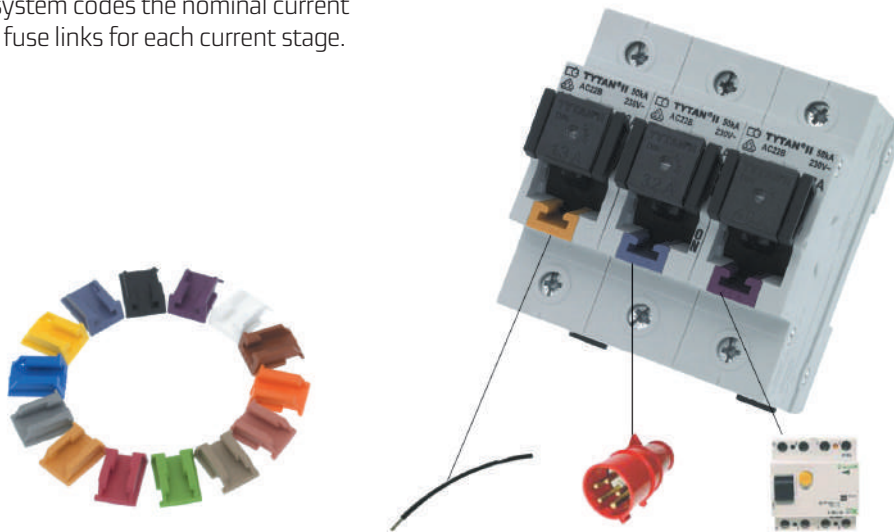

e.g.: 13 A diameter 1,5 mm²

e.g.: 32 A CEE connector

e.g.: 40A for the ground-fault circuit

TYTAN® II FUSE LINKS

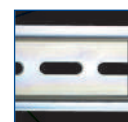

35 mm DIN rail

D0 - Fuse link with an integrated flashing response indicator for use with the TYTAN® II fuse sleeve disconnecter



Low loss due to the fuse sleeve

1. Independent constant terminal pressure
2. Spring loaded terminal
3. Double contact saves 0.8 W per pole
4. Ceramic tube
5. Quartz sand
6. Fuse wire
7. Base contact
8. Cover for closing sand

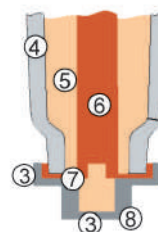

The set for TYTAN II fuse switch disconnecter consists of:

- 3 x D0 fuse link
- 3 x fuse sleeve
- box for reserve fuse links



Table 166. TYTAN II fuse sleeves

Versions	colour	Index no.	Weight [kg]	Package [pcs.]
1A set	orange	0000102601T	0,13	1/12
2A set	pink	0000102602T	0,13	1/12
4A set	brown	0000102604T	0,13	1/12
6A set	green	0000102606T	0,13	1/12
10A set	red	0000102610T	0,13	1/12
13A set	ochre	0000102613T	0,13	1/12
16A set	grey	0000102616T	0,13	1/12
20A set	blue	0000102620T	0,13	1/12
25A set	yellow	0000102625T	0,13	1/12
32A set	lilac	0000102632T	0,13	1/12
35A set	black	0000102635T	0,13	1/12
40A set	purple	0000102640T	0,13	1/12
50A set	white	0000102650T	0,13	1/12
63A set	copper	000010 2663T	0,13	1/12

TYTAN II ACCESSORIES

Set of three jumpers in sleeves in a box for mounting on a mounting rail



Table 167. TYTAN II fuse sleeves with jumpers

Versions	Index no.	Weight [kg]	Package [pcs.]
Jumper set	0002102300T	0,2	1/12

After installation in the device, the set transforms it into a switch disconnector

Lock against restarting in the mounting rail box

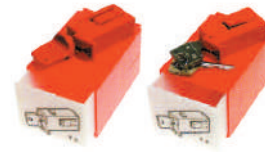

Table 168. TYTAN II fuse sleeves with jumpers

Versions	colour	Index no.	Weight [kg]	Package [pcs.]
5A5 cylindrical lock	black	0001020071T	0,09	1/12
5A4 cylindrical lock	blue	0001020072T	0,09	1/12
5A3 cylindrical lock	green	0001020073T	0,09	1/12
5A1 cylindrical lock	yellow	0001020074T	0,09	1/12
5A2 cylindrical lock	red	0001020075T	0,09	1/12
Plastic lock	black	0001020081T	0,06	1/12
Plastic lock	blue	0001020082T	0,06	1/12
Plastic lock	green	0001020083T	0,06	1/12
Plastic lock	yellow	0001020084T	0,06	1/12
Plastic lock	red	0001020085T	0,06	1/12

D01 - TYTAN® I FUSE SWITCH DISCONNECTOR



35 mm DIN rail

- flashing response indicator
- automatic coding for current values of the fuse link
- possibility of sealing



Table 169. Technical data

Classification	Fuse switch disconnecter
Standard	IEC/EN 60947-3
Adapted to fuse switch disconnectors	D01: 1, 2, 4, 6, 10, 13, 16; gL, gG, aM classes
flammability class/track resistance	V0, glowing wire testing 960 °C / CTI 600
Degree of protection/touch protection	IP 20 / protection against finger and palm touch
Rated operating voltage U_e	
-AC	400 V
-DC	1-pole 110 V, 2-pole 220 V
Rated switching current I_e	16A
Rated impulse withstand voltage U_{imp}	6kA
Rated short-circuit current I_{cm}	50 kA _{eff}
Utilization category AC	22B
Overvoltage category/pollution degree	IV/3 (DIN VDE 0110)
Terminal type	stainless steel cage terminals 1.5...25 mm ² ; MD 2.5 Nm

Dimensions

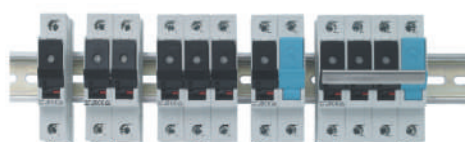
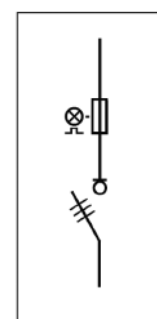
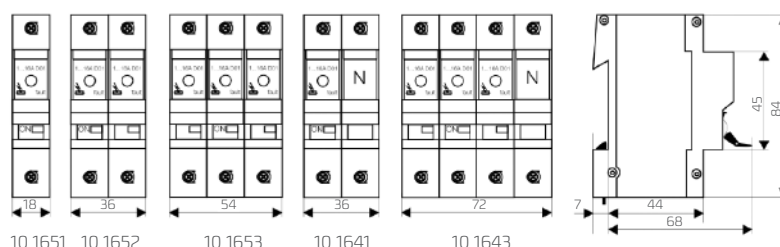

Fuse sleeve

- it has a built-in optoelectrical flashing signalling device of the fuse response
- flashing error light replaces the unreliable mechanical indicators. As a result, a control opening is not usually required, the protective insulation remains intact
- protects the operator. When heated up to 100°C, the fuse is not directly touched by fingers during replacement



Table 170. TYTAN I Fuse switch disconnecter

Versions	Index no.	Weight [kg]	Package [pcs.]
1-pole	0000101651T	0,09	12
2-pole	0000101652T	0,18	6
3-pole	0000101653T	0,27	4
1-pole + N	0000101641T	0,17	6
3-pole + N	0000101643T	0,35	3

Automatic coding

TYTAN® I structurally codes the power of the rated fuse current. The system is operated with one fuse sleeve for all current powers.

The coding of the maximum applicable rated fuse current in the fuse disconnecter is done by setting the appropriate value on the belt pulley.

By inserting the fuse in the fuse sleeve, the coding spring is ejected depending on its rated current value.

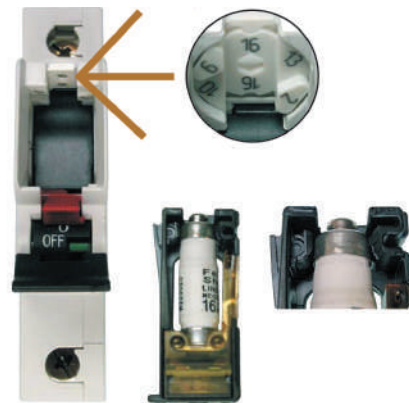

DO - TYTAN® T FUSE SWITCH DISCONNECTOR



35 mm DIN rail

- flashing response indicator
- for DO and cylindrical 10x38 mm fuse switches
- universal fuse sleeve
- only 4TE width
- possibility of sealing

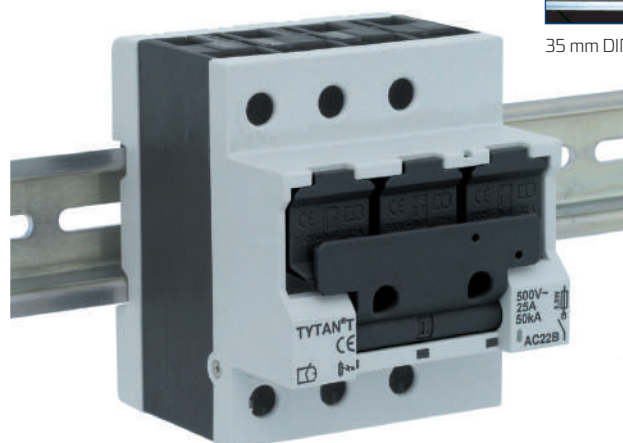

Table 171. Technical data

Classification	Fuse switch disconnector
Standard	IEC/EN 60947-3
Adapted to fuse switch disconnectors	D01: 1, 2, 4, 6, 10, 13, 16 A D02: 20, 25, 32, 35, 40, 50, 63 A gL, gG, aM class
Adapted to fuse switch disconnectors	Cylindrical 10x38 mm 2, 4, 6, 8, 10, 12, 16, 20, 25, 32A
flammability class/track resistance	V0, glowing wire testing 960°C / CTI 600
Degree of protection/touch protection	IP20 / protection against finger and palm touch
Rated operating voltage U_e	400 V AC
Rated switching current I_e	D0: 63A; 10x38: 32A
Rated impulse withstand voltage U_{imp}	6 kA
Rated short-circuit current I_{cm}	50 kA _{eff}
Utilization category AC	22B
Overvoltage category/pollution degree	IV/3 (DIN VDE 0110)
Terminal type	stainless steel cages terminals 1.5...25 mm ² ; MD 3.5 Nm

Dimensions

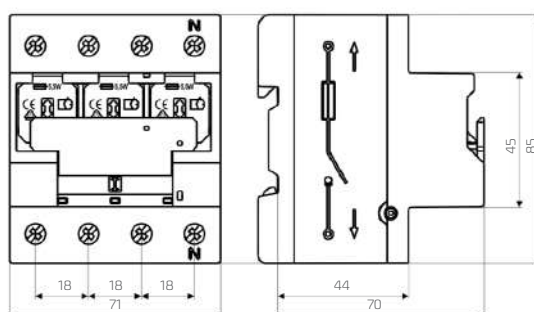

Table 172. TYTAN T Fuse switch disconnector

Versions	Index no.	Weight [kg]	Package [pcs.]
3-pole	0000104213T	0,40	3
3-pole + N	0000104215T	0,40	3
Reducing spring of the D02 fuse sleeve to D01 and for 10x38 mm	0000101774T	0,01	12

DO - CORON[®] 2 FUSE SWITCH DISCONNECTOR



35 mm DIN rail

- flashing response indicator
- universal fuse sleeve
- possibility of sealing
- possibility of padlocking (padlock handle up to Ø5 mm)



Table 173. Technical data

Classification	Fuse switch disconnectors
Standard	IEC/EN 60947-3
Adapted to fuse switch disconnectors	D01: 1, 2, 4, 6, 10, 13, 16 A D02: 20, 25, 32, 35, 40, 50, 63 A gL, gG, aM class
flammability class/track resistance	V0, glowing wire testing 960°C / CTI 600
Degree of protection/touch protection	IP20 / protection against finger and palm touch
Rated operating voltage U_e	400 V
-AC	1-pole 110 V, 2-pole 220 V
-DC	
Rated switching current I_e	63 A
Rated impulse withstand voltage U_{imp}	6 kA
Rated short-circuit current I_{cm}	50 kA _{eff}
Utilization category	AC 22B
Overvoltage category/pollution degree	IV/3 (DIN VDE 0110)
Terminal type	stainless steel cage terminals 1.5...35 mm ² ; MD 4 Nm

Dimensions

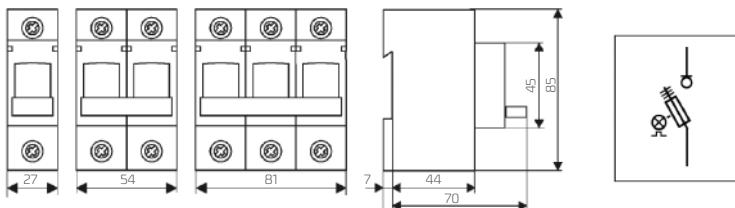

Table 174. CORON 2 Fuse switch disconnectors

Versions	Index no.	Weight [kg]	Package [pcs.]
1-pole	0000104651T	0,13	12
2-pole	0000104652T	0,26	6
3-pole	0000104653T	0,40	4
1-pole + N	0000104641T	0,26	6
3-pole + N	0000104643T	0,53	3
Reducing spring of the D02 fuse sleeve to D01	0000104601T	0,01	12

CORON® DUO-DO FUSE SWITCH DISCONNECTOR



35 mm DIN rail

- fuse disconnecter for DO-size fuse links with a fuse link burnout indicator and contact position indicator
- width: 27 mm per pole
- optical indicator of fuse activation
- mechanical disconnecter position indicator
- optical connector ON/OFF indicator
- version with an integrated auxiliary switch
- simultaneous switching of all poles
- easy fuse replacement thanks to a fuse locking sleeve with a finger guard
- power supply connectable from
- either side sealable



Table 175. Technical Data

Classification	Fuse switch disconnecter
Standard	IEC / EN 60947-1, IEC / EN 60947-3 IEC / EN 60947-1 IEC / EN 60269-1 VDE 0660 IEC / EN 60969-3-1 DIN VDE 0636, DIN 49522
Rated switching current: I_e	63 A
Rated short circuit breaking capacity: I_{cm}	50 kA
Rated insulation voltage: U_i	500 V
Rated impulse withstand voltage: U_{imp}	6 kV
Category of use	AC 22B
Overtoltage category/pollution degree	IV/3 (DIN VDE 0110)
Power loss per pole - no fuse	L1, L2, L3 – 2 W; N – 1,5 W
Maximum fuse permissible power dissipation P_n	5,5 W
Optical fuse activation indicator - Rated operating voltage range	AC 60-400 V
Auxiliary switch -Rated current/operating current U_o/I_e	AC 250 V/5 A
Flammability class	V0, glow wire test 960°C
Ambient temperature	-25°C ÷ 60°C
Protection against direct touch	BGV A3
Terminal type	Stainless steel cage terminal 1,5÷35 mm ² ; MD 3 Nm

ON/OFF position

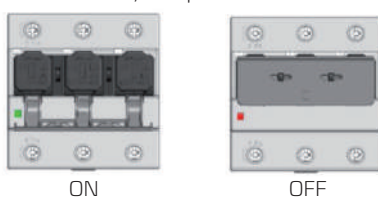

Dimensions

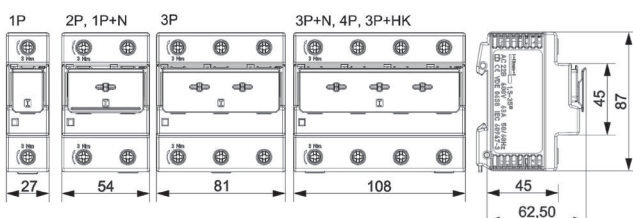
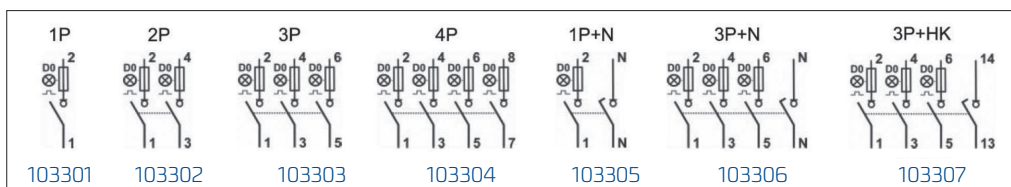

Table 176. CORON® DUO Fuse switch disconnector

Version	Index number	Weight [kg]	Packaging [pcs]
1-pole	0000103301T	0,107	12
2-pole	0000103302T	0,206	6
3-pole	0000103303T	0,302	4
4-pole	0000103304T	0,400	6
1-pole + N (N leading/delayed)	0000103305T	0,194	6
3-pole + N (N leading/delayed)	0000103306T	0,388	3
3-pole + auxiliary switch	0000103307T	0,388	3



D0-FUSE BASE E14, E18

- width: 27 mm per pole
- larger coupling surface
- double cage terminal on the input
- IP rating IP20
- mounting: DIN rail - snap mounting



35 mm DIN rail



Table 177. Version

Fuse base E14	Index number	Packaging
1-pole	0000284001T	15
3-pole	0000284003T	5
Fuse base E18		
1-pole	0000284011T	15
3-pole	0000284013T	5

Fuse holder: Table 773. Accessories

For E18 fuse bases, size 007, use fuse reduction sleeves No. 0000727407T only.

Classification	Fuse base	
	E14	E18
Standard	IEC/EN 60969-3; DIN VDE 0636-3	
Suitable for fuse links	D01: 1, 2, 34, 6, 10, 13, 16 A	D01*: 1, 2, 34, 6, 10, 13, 16 A
		D02: 20, 25, 32, 35, 40, 50, 63 A
	class gL, gG, aM	
Flammability class / resistance to creeping currents	VO, glow wire test 960°C/CTI 600	
Protection type / touch protection type	IP20 / finger and hand touch protection	
Rated operating voltage U_e		
-AC	400 V	
-DC	250 V	
Rated thermal current I_{th}	16 A	63 A
Rated impulse withstand voltage U_{imp}	6 kV	
Rated breaking capacity current I_{cm}	AC 50 kA _{eff} / DC 8 kA _{eff}	
	stainless steel cage terminals	
Terminal type	Input 1...35 mm ² + 16 mm ² ; output 1...25 mm ²	
	MD 2,0 Nm	MD 2,5 Nm

* use fuse reduction sleeve No.0000727407T

Dimensions

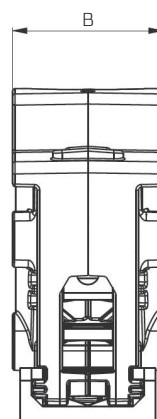
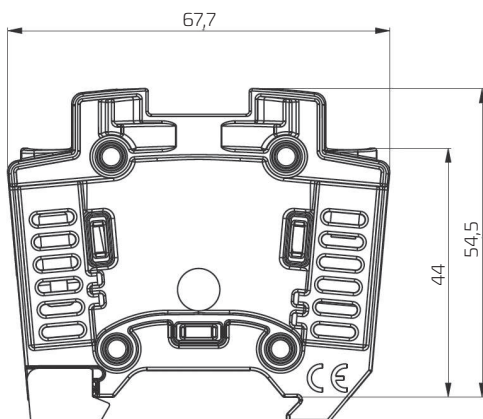

Type	B [mm]
1-pole	26,8
3-pole	80,4

DO FUSE LINKS

400 V~/250 V-; DIN 49522 DIN VDE 0636 IEC 60269

A snap-on spare parts container installed in the switchboard allows for immediate replacement of inserts and re-connection of the circuit.



Table 178. Fuse links in the snap-on container for the TH busbar

Versions	Index no.	Weight [kg]	Package [pcs.]
12X 2A D01 in the 1.5TE container	0000101202T	0,10	1/24
12X 4A D01 in the 1.5TE container	0000101204T	0,10	1/24
12X 6A D01 in the 1.5TE container	0000101206T	0,10	1/24
12X 10A D01 in the 1.5TE container	0000101210T	0,11	1/24
12X 13A D01 in the 1.5TE container	0000101213T	0,11	1/24
12X 16A D01 in the 1.5TE container	0000101216T	0,11	1/24
12X 20A D02 in the 3TE container	0000101220T	0,18	1/12
12X 25A D02 in the 3TE container	0000101225T	0,18	1/12
12X 32A D02 in the 3TE container	0000101232T	0,19	1/12
12X 35A D02 in the 3TE container	0000101235T	0,21	1/12
12X 40A D02 in the 3TE container	0000101240T	0,21	1/12
12X 50A D02 in the 3TE container	0000101250T	0,22	1/12
12X 63A D02 in the 3TE container	0000101263T	0,22	1/12
13x set of 12 fuse switch disconnectors The set contains all fuse switch disconnectors from the range 2..63	0000101200T	2,10	1



Table 179. Fuse links

Versions	Index no.	Weight [kg]	Package [pcs.]
D01 2A	0000100202T	0,10	50
D01 4A	0000100204T	0,10	50
D01 6A	0000100206T	0,10	50
D01 10A	0000100210T	0,11	50
D01 13A	0000100213T	0,11	50
D01 16A	0000100216T	0,11	50
D02 20A	0000100220T	0,18	50
D02 25A	0000100225T	0,18	50
D02 32A	0000100232T	0,19	50
D02 35A	0000100235T	0,21	50
D02 40A	0000100240T	0,21	50
D02 50A	0000100250T	0,22	50
D02 63A	0000100263T	0,22	50



CALIBRE INSERT

DIN 49523 DIN VDE 0636 IEC 60269



Table 180. Calibre insert in the snap-on container for the TH rail

Versions	Index no.	Weight [kg]	Package [pcs.]
12X 2A D01 in the 1.5TE container	0000101302T	0,03	1/24
12X 4A D01 in the 1.5TE container	0000101304T	0,03	1/24
12X 6A D01 in the 1.5TE container	0000101306T	0,03	1/24
12X 10A D01 in the 1.5TE container	0000101310T	0,03	1/24
12X 2A D02 in the 3TE container	0000101402T	0,03	1/24
12X 4A D02 in the 3TE container	0000101404T	0,03	1/24
12X 6A D02 in the 3TE container	0000101406T	0,03	1/24
12X 10A D02 in the 3TE container	0000101410T	0,03	1/24
12X 16A D02 in the 3TE container	0000101416T	0,03	1/24
12X 20A D02 in the 3TE container	0000101420T	0,03	1/24
12X 25A D02 in the 3TE container	0000101425T	0,03	1/24
12X 35A D02 in the 3TE container	0000101435T	0,03	1/24
12X 50A D02 in the 3TE container	0000101450T	0,03	1/24
Full set of 13x12 calibre inserts from the range 2-50 A	0000101300T	0,39	1

Table 181. Calibre insert

Versions	Index no.	Weight [kg]	Package [pcs.]
D01 E14 2A	0000100302T	0,001	50
D01 E14 4A	0000100304T	0,001	50
D01 E14 6A	0000100306T	0,001	50
D01 E14 10A	0000100310T	0,001	50
D02 E18 2A	0000100402T	0,001	50
D02 E18 4A	0000100404T	0,001	50
D01 E18 6A	0000100406T	0,001	50
D01 E18 10A	0000100410T	0,001	50
D01 E18 16A	0000100416T	0,001	50
D01 E18 20A	0000100420T	0,001	50
D01 E18 25A	0000100425T	0,001	50
D01 E18 35A	0000100435T	0,001	50
D01 E18 50A	0000100450T	0,001	50



Table 182. Accessories

Versions	Index no.	Weight [kg]	Package [pcs.]
Key for mounting the calibre insert	0000101400T	0,02	1/12
Plastic D02 fuse head with a measuring hole	0000126024T	0,01	20
Reduction insert for fuse switch disconnectors D01	0000121401T	0,01	20
Porcelain D02 fuse head with a measuring hole	0000127024T	0,01	20
Porcelain D01 fuse head with a measuring hole	0000127025T	0,01	20



0000121401T



the publication is only for information purposes
and it is not the offer in understanding of the law

KEY ACCOUNT MANAGER

Rafał Kamiński (English, Russian) Central Europe, South East Europe	rafal.kaminski@apator.com	+48 506 009 338
Michael Roclawski (German, English) Germany, Austria, Switzerland	michael.roclawski@apator.com	+48 506 009 339
Krzysztof Zdrojewski (English) Middle East, South America, Asia, Africa	krzysztof.zdrojewski@apator.com	+48 506 009 309
Jevgenijus Samuchovas (Lithuanian, Russian) Eastern Europe, Baltic Countries	jevgenijus.samuchovas@apator.com	+370 62 842709
Josef Kalleder (Romanian, English) Romania, Rep. of Moldova	josef.kalleder@apator.com	+40 74 5267192

TECHNICAL SUPPORT

Business Development Manager

Łukasz Melkowski (English)	lukasz.melkowski@apator.com	+48 506 009 334
----------------------------	-----------------------------	-----------------



APATOR SA

ul. Gdańska 4a, lok C4, 87-100 Toruń, Poland

Correspondence address

Apator S.A. Centrum

Ostaszewo 57C, 87-148 Łysomice, Poland

apator@apator.com

phone +48 56 61 91 235, +48 56 61 91 316, fax +48 56 61 91 295