



# NRM8PV Channel Nut

0.0 Sheet thickness 0.0 mm

## Information

### Usage

Assembly of BUF... and PUF holders  
to CWC100H50... profiles

### Material

S250GD steel in:

Magnelis®, MagiZinc®, PosMAC coating

Available finishes:

E - Stainless steel

### Additional information

- quick installation of panel fixing clamps without the need to hold on when tightening the nuts from underneath the system - geometry enabling the nut to lock into the CWC100H50... profile while tightening
- made of Magnelis®-coated material with very high corrosion resistance Optimal tightening torque = 12 - 15 Nm

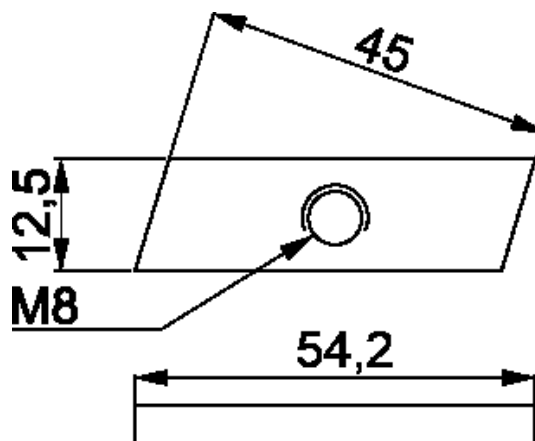

## Product versions

Symbol	Catalogue number	Quantity (pcs.)
NRM8PV	660245	100

## Examples

